

EMERGING NETWORK BASED
INFORMATION SERVICES MARKETS

INPUT

About INPUT

INPUT provides planning information, analysis, and recommendations to managers and executives in the information processing industries. Through market research, technology forecasting, and competitive analysis, INPUT supports client management in making informed decisions.

Continuous-information advisory services, proprietary research/consulting, merger/acquisition assistance, and multient studies are provided to users and vendors of information systems and services (software, processing services, turnkey systems, systems integration, professional services, communications, systems/software maintenance and support).

Many of INPUT's professional staff members have more than 20 years' experience in their areas of specialization. Most have held senior management positions in operations, marketing, or planning. This expertise enables INPUT to supply practical solutions to complex business problems.

Formed as a privately held corporation in 1974, INPUT has become a leading international research and consulting firm. Clients include more than 100 of the world's largest and most technically advanced companies.

INPUT OFFICES

North America

Headquarters

1280 Villa Street
Mountain View, CA 94041
(415) 961-3300
Telex 171407 Fax (415) 961-3966

New York

Parsippany Place Corp. Center
Suite 201
959 Route 46 East
Parsippany, NJ 07054
(201) 299-6999
Telex 134630 Fax (201) 263-8341

Washington, D.C.

8298 C, Old Courthouse Rd.
Vienna, VA 22180
(703) 847-6870 Fax (703) 847-6872

International

Europe

INPUT LTD.

Piccadilly House
33/37 Regent Street
London SW1Y 4NF, England
01-493-9335
Telex 27113 Fax 01-629-0179

INPUT s.a.r.l.

29 rue de Leningrad
75008 Paris, France
01-44-80-48-43
Fax 01-44-80-40-23

Japan

FKI, Future Knowledge Institute
Saida Building,
4-6, Kanda Sakuma-cho
Chiyoda-ku,
Tokyo 101, Japan
03-864-4026 Fax 001-03-864-4114

Published by
INPUT
1280 Villa Street
Mountain View, CA 94041-1194
U.S.A.

Market Analysis Program (MAP)

***Emerging Network-Based Information
Services Markets***

Copyright ©1988 by INPUT. All rights reserved.
Printed in the United States of America.

No part of this publication may be reproduced or
distributed in any form or by any means, or stored
in a data base or retrieval system, without the prior
written permission of the publisher.

Abstract

This report, produced as part of INPUT's Market Analysis and Planning Service (MAPS), takes a comprehensive look at the opportunities for INPUT's clients that result from the entry into the U.S. marketplace for key telecommunications services.

The services considered are: small aperture satellites, Integrated Services Digital Network (ISDN), advanced message services, gateways by telcos to E-Mail and data bases, T1, Electronic Data Interchange (EDI), data transmission by radio and cellular telephone, and voice mail.

Opportunities and strategies are derived for vendors of Processing Services, Network Services, Proprietary Electronic Information Services, and Professional Services.

This report contains 104 pages, including 40 exhibits.



Digitized by the Internet Archive
in 2015

<https://archive.org/details/emergingnetworkb2951unse>

Table of Contents

I	Introduction	1
	A. Background	1
	B. Scope of the Report	2
	C. Developments in Regulation and Transmission Technology Create Opportunities	4
	D. Opportunities	9
	E. Methodology	10
	F. Purpose	11
	G. Related Reports	11
<hr/>		
II	Executive Overview	13
	A. Emerging Telecommunications Services Cover a Wide Range of Technology	13
	B. Users Find the Emerging Telecommunications Services Important	14
	C. Vendors of Emerging Telecommunications Services Don't Understand the User Needs	16
	D. Users Want Help from Outside Firms	18
	E. Market Size and Growth	19
<hr/>		
III	Market Definition and Forecast	21
	A. Overview	21
	B. Forecasts	24

Table of Contents (Continued)

IV	Description of Telecommunications Services and Reason for Their Growth	29
	A. Introduction	29
	B. Very Small Aperture Terminal (VSAT) Satellite Services	31
	C. Integrated Services Digital Network (ISDN)	33
	D. Advanced Messaging	37
	E. Gateways from Local Bell Companies	40
	F. T1 Wide Band Transmission Services	41
	G. Electronic Data Interchange Services (EDI)	44
	H. Data/Message Transmission by Radio	45
<hr/>		
V	The User Point of View	51
	A. Introduction	51
	B. Satellites with Very Small Aperture (VSAT)	52
	C. Integrated Services Digital Network (ISDN)	54
	D. Advanced Message Services	56
	E. Gateways by Telcos to E-Mail and Data Bases	58
	F. T1 Transmission Services	60
	G. Electronic Data Interchange (EDI)	62
	H. Transmission of Data by Radio and Cellular Telephone	64
<hr/>		
VI	The Vendor Point of View	67
	A. Why Solicit the Vendor's Point of View?	67
	B. Emerging Telecommunications Services Vendors' User Views	68
	C. Vendor Opportunities	69
<hr/>		
VII	Voicemail: A Unique Service	75
	A. Description of Voicemail	75
	B. Advantages of Voicemail	77
	C. Opportunities Created by Voicemail	78

Table of Contents (Continued)

VIII	Conclusions and Recommendations	79
A.	Recommendations to Processing Service Vendors	79
B.	Recommendations to Network Service Vendors	82
C.	Recommendations to Proprietary Electronic Information Services Vendors	84
D.	Recommendations to Professional Service Vendors	85
E.	Concluding Remarks	87
<hr/>		
A	Appendix: User Questionnaire	89
B	Appendix: Vendor Interview Guide	99

Exhibits

I	-1 The Communications Situation	3
	-2 Changes and Opportunities	5
	-3 Applications for Emerging Telecommunications Services	6
	-4 Communications Services and Examples	8
	-5 Opportunities	9
<hr/>		
II	-1 Emerging Telecommunications Services Cover a Wide Range of Technology	14
	-2 Users Find the Emerging Telecommunications Services Important	15
	-3 Vendors of Emerging Telecommunications Services Don't Understand the Total User Needs	17
	-4 Users Want Help from Outside Firms	18
	-5 Market Size and Growth	20
<hr/>		
III	-1 How Strongly Emerging Telecommunications Services Impact Other Services Provided to Users	23
	-2 Network Design, Installation, and VANs Impacted by Emerging Communications Services—User Expenditures	25
	-3 On-Line Data Bases—User Expenditures	26
	-4 Design, VAN, and Data Base Information Impacted by Emerging Communications Services—User Expenditures	27
<hr/>		
IV	-1 VSAT System	32
	-2 ISDN	34
	-3 Messaging Services	38
	-4 Gateways	40
	-5 T1 System	42
	-6 VAN/RCS Role in EDI	45
	-7 Host to Remote Data Network by Radio	47
	-8 Data Transmission by Cellular Radio	48

Exhibits (Continued)

V	-1 Satellites with Very Small Aperture	53
	-2 Integrated Services Digital Network (ISDN)	55
	-3 Advanced Message Services	57
	-4 Gateways by Telcos to E-Mail and Data Bases	59
	-5 T1 Transmission Service	61
	-6 Electronic Data Interchange (EDI)	63
	-7 Transmission of Data by Radio and Cellular Telephone	65
<hr/>		
VI	-1 Emerging Telecommunications Service Vendors' Relationships and Knowledge of User Needs	69
	-2 Vendors' Viewpoint on Outside Firms Designing Networks Using Their (the Vendors') Service Offerings	70
	-3 Role of Outside Firms in Designing Networks for Users	71
	-4 Outside Firms Adding Value to the Emerging Service and Reselling It	73
	-5 Opportunities for Providers of Proprietary Electronic Data Bases	74
<hr/>		
VII	-1 Description of Voicemail	76
	-2 Advantages of Voicemail	77
<hr/>		
VIII	-1 Recommendations to Processing Service Vendors	80
	-2 Recommendations to Network Service Vendors	83
	-3 Recommendations to Proprietary Electronic Information Service Vendors	84
	-4 Recommendations to Professional Service Vendors	86

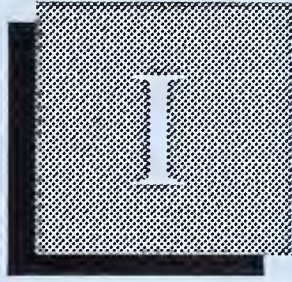

Introduction



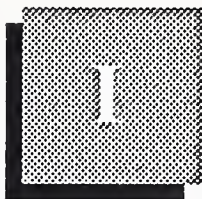

Introduction

A

Background

This report, produced by INPUT as part of the Market Analysis Program (MAP), examines opportunities for clients of INPUT created by the emergence of new network-based telecommunications services. These opportunities exist because of new developments in communications services, which in turn have been caused by developments in technology and changes in FCC regulations.

Opportunities for INPUT's clients include providing a large range of telecommunications services, design-assistance services, and proprietary electronic-based information to users. Which particular opportunities a vendor chooses to take advantage of depends upon its view of the market and upon how the market opportunities intersect with that vendor's skills and strategic goals.

Opportunities have been classified in the following manner:

- Design and build (install) networks for users - This may be restricted to consulting (only) to users to help them decide how a new network will match corporate needs (without actual design or installation). However, the task may also be expanded to include development of the network to the point of supplying a turnkey system to the user.
- Network operation and management - An experienced vendor can actually manage and operate the network for the user, including managing the network to ensure that it is operating efficiently and meeting user needs. Network changes to meet new corporate needs can be implemented. Quality control, usage control, and costs all can be

managed by a vendor. This would be considered a new form of systems operations—a submode of processing services.

- Network Transmission Services - Vendors can decide that they will provide telecommunications services as a public network. They can decide to enter the field alone or to enter the field with a partner. It is likely that a processing services vendor will choose to enter the market with a telecommunications service that requires a great deal of processing “value added”—e.g., trade document interchange.
- Proprietary Electronic Data Bases - Another opportunity is to provide the proprietary information that is to be transported by the communications network, without being involved in the actual network. An example is legal data bases.

This report will define the new (or increasing) opportunities that will exist because of the emerging telecommunications services, and will point out various ways in which INPUT’s clients can start to take advantage of these opportunities.

B

Scope of the Report

Communications is a very complex topic. This complexity is favorable in that it creates many new opportunities for different companies. A company must have a high degree of skill to be able to take advantage of these opportunities, which is a competitive advantage for sophisticated vendors.

Exhibit I-1, The Communications Situation, shows the complexity of communications networks and the wide range of opportunities.

- The first market differentiation is for communication that is only intra-enterprise versus communication that is inter-enterprise. Internal-to-the-enterprise (intra) communications can be implemented by both public and private networks. Generally a combination of both will be used. Communication that is external to the enterprise (inter) generally goes via public networks.
- Internal-to-the-enterprise communications can best be divided (again) into two classes of user communications—large computer sites and general user sites. This is shown in the exhibit by the high-capacity network delineation. The high-capacity network is where opportunities exist for T1, fiber optics, and wideband satellite communications. It is also where the opportunities for network design and management services exist.

EXHIBIT I-1

THE COMMUNICATIONS SITUATION

Internal Enterprise

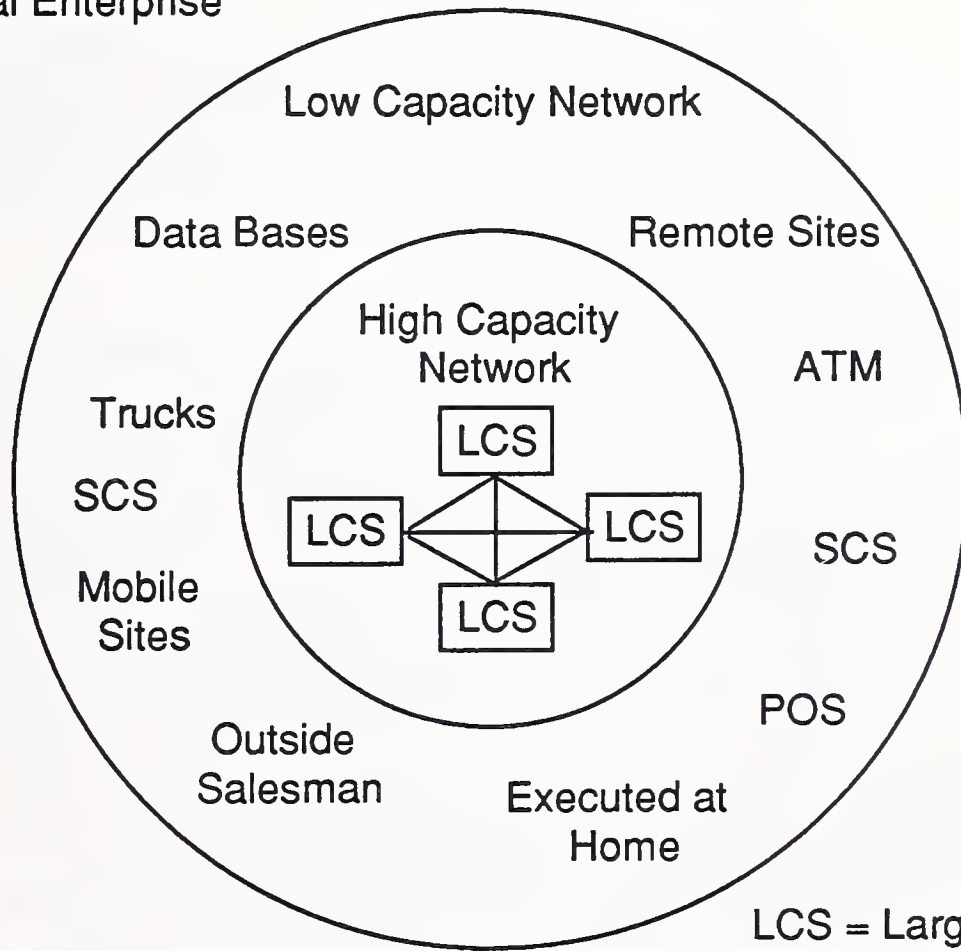

LCS = Large Computer Site

SCS = Small Computer Site

External Enterprises

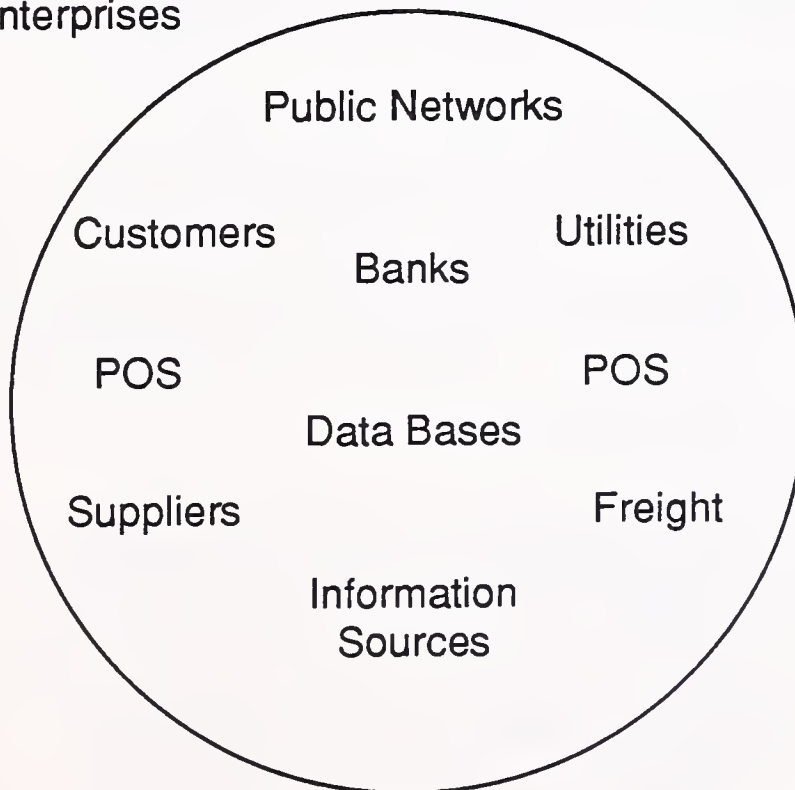

- The low-capacity network connects to the smaller computer sites and to other locations, such as POS terminals and sites where there is a relatively small amount of communications (although there may be many sites). Communications services for the low-capacity network include public networks, messaging, etc., but generally not leased lines.
- The low-capacity network also includes “unique” sites, such as trucks performing deliveries and remote locations with poor public communications (such as rural construction sites). Here there are opportunities for unique services, such as small aperture satellites and data via radio transmission.
- The other enterprises that a company communicates with are generally reached by public networks. There are opportunities to make these communications simpler and provide third-party services such as funds transfer and information base access. There is less actual data moving between each of the specific sites, but there are many sites in total. In addition, compatibility, time differences, etc. are needs that create opportunities. The opportunities are for advanced message communications, data gateways, information data bases, etc.

C

Developments in Regulation and Transmission Technology Create Opportunities

New opportunities for INPUT's clients (Exhibit I-2) are caused indirectly by new technology and FCC regulations. In turn these two driving forces create emerging telecommunications services. These emerging telecommunications services in turn provide opportunities for INPUT's clients. How these emerging telecommunications services provide opportunities for INPUT's clients is the topic of this report.

- FCC regulatory changes have, for example, allowed the local Bell Companies to offer gateways (a simple menu appears on the user's PC) that allow the user to connect to a selection of data bases and Electronic Mail services without subscribing to these services. Cellular telephone (a service allowed by regulatory decision) has created an opportunity to transmit and receive data without a telephone line, to and from a mobile site.
- New technology has increased the capability of network equipment and network services. New terminal devices—e.g., FAX and graphic capability—have increased the volume and types of information available for transmission. For example, new technology has increased the capability of facsimile, which has caused a great increase in the installed base of facsimile units. The large installed facsimile base has in

EXHIBIT I-2

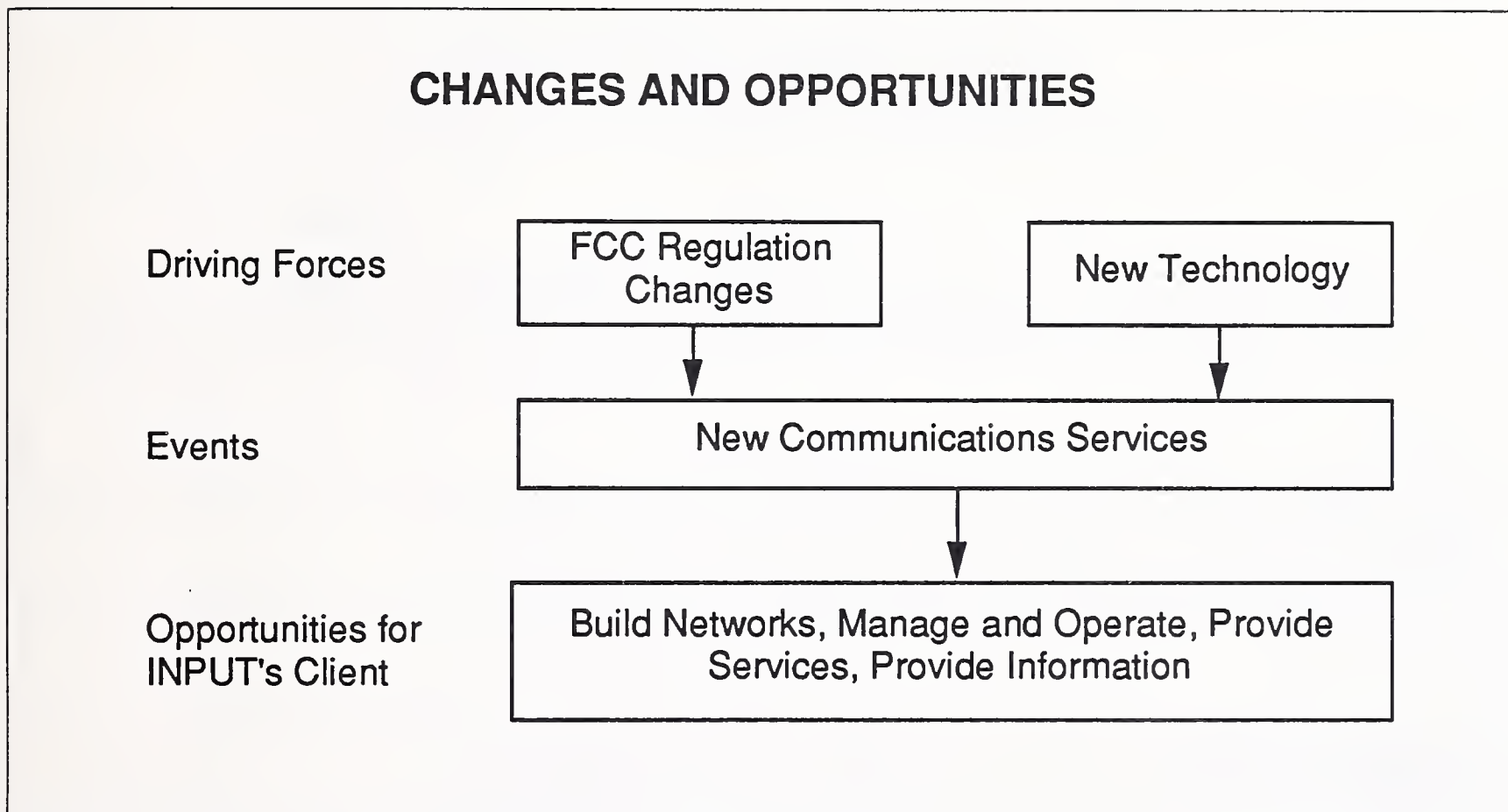

turn created the market for a service to convert PC data to a form suitable for output on a facsimile device.

Emerging telecommunications services create opportunities to process information since they have made the information more accessible. Also, emerging telecommunications services must be combined into networks for companies. These networks must be managed, and can also be offered to the public. All of these opportunities are suitable for the appropriate information processing and network transmission vendors.

Exhibit I-3 shows how typical user locations can use emerging telecommunications developments.

- Very Small Aperture Satellite Terminals (VSAT) allow wide bandwidth information to be economically transmitted to large and small computer /user sites. VSATs also can be used at remote or movable locations, such as construction sites and trucks.
- ISDN allows simultaneous voice and data transmittal to many different locations.

EXHIBIT I-3

APPLICATIONS FOR EMERGING TELECOMMUNICATIONS SERVICES

Typical User Locations Impacted	Satellites	Fiber Optics & T1	Data Via Radio	Short-Range Microwave	ISDN
Large Computer Sites	X	X	X	X	X
Small Computer Sites	X		X		X
POS Retail	X		X		X
Salesmen on the Road			X		X
Trucks (Moving Vehicles)	X		X		
Remote, Inaccessible Sites	X		X	X	
Business in the Home			X		X
Bank ATMs			X		X
Public Data Bases	X		X		X
Private Data Bases	X	X	X		X

- Data by radio can be transmitted to remote or moving sites. It also can be used to bypass local telephone services when the economics of the situation warrants.
- Businesses in the home can receive data via radio and through the local loop.

New developments in FCC regulation and in technology have resulted in a series of emerging telecommunications services. In this report these services will be examined to determine what opportunities they create for INPUT's clients.

- Emerging telecommunications services are defined as the basic service and not an application of that service (Exhibit I-4). For example, small aperture satellite communications is an emerging telecommunications service. It has lots of applications. One of these applications is to transmit X-ray images between hospitals.
- The emerging telecommunications services will be examined for opportunities that they create. Using the same example, transmission of X-ray information is only one of the many opportunities that the existence of small-aperture satellites creates. It would be far too restrictive to study just transmission of X-ray information as an industrywide opportunity. The real industry opportunities are the many applications that have been made economically practical by small-aperture satellites (such as receiving POS data from a large number of stores in a chain), or made physically practical (such as reaching remote sites where a large antenna cannot be easily installed).

EXHIBIT I-4

COMMUNICATIONS SERVICES AND EXAMPLES

Communications Service	Typical Applications
Small Aperture Satellites	<ul style="list-style-type: none"> • X-Ray Image Transmission • Data to Remote Sites
ISDN	<ul style="list-style-type: none"> • Simultaneous Voice and Data Calls • Video Conference
Advanced Message Services	<ul style="list-style-type: none"> • POS Data Collection • PC Output to Facsimile
Gateway from Local Bell CU's to E-Mail and Data Bases	<ul style="list-style-type: none"> • Home Shopping • Pull Bulletin Boards
T1 Services	<ul style="list-style-type: none"> • Corporate Network Integration • Voice/Data/Image
EDI	<ul style="list-style-type: none"> • Automatic Ordering • Trade Document Interchange
Data by Radio	<ul style="list-style-type: none"> • Stock Quotes • Routing Information to Trucks • Crop Price to Farmers

D**Opportunities**

Multiple opportunities have been created by emerging telecommunications services. Which opportunities a company decides to follow depends upon the interaction of the market with the skills and strategies of the company. Exhibit I-5 shows the multiple opportunities created by each emerging telecommunications service from the viewpoint of vendors that are in the areas of network processing, VANs, and providing proprietary electronic information.

EXHIBIT I-5

OPPORTUNITIES

Emerging Telecommunications Services	Design & Build the Network for a User	Operate the Network for a User	Provide as a Value-Added Communications Service, Include Processing	Provide Information
Small Aperture Satellites	X	X		X
ISDN	X	X		X
Advanced Message Services	X			X
Gateway from Local Bell Companies to E-Mail and Data Bases				X
T1 Services	X	X		X
EDI	X	X		X
Data by Radio	X	X	X	X

- Small aperture satellites, T1 services, EDI, and ISDN provide opportunities to design, build, and operate networks, as well as opportunities to provide proprietary electronic information to users via these networks.
- Advanced message services and gateways are (services) provided by companies that provide public telecommunications services. These particular emerging telecommunications services provide opportunities for:
 - Consulting to users as to how they can take advantage of these new services
 - Vendors to deliver proprietary information to users by connecting with these services
- Data by radio provides a full range of opportunities for INPUT's clients. Because data by radio is usually local, it is reasonable for a company to provide it as a network service in a local area. Thus the entry charge to use data by radio or cellular telephone is low. In the case of cellular the network already exists. In the case of radio the equipment costs are low.

E

Methodology

The research for this report came from several information sources. INPUT first questioned a majority of its clients to determine what issues needed consideration and clarification in this report.

Seven in-depth discussions were held with vendors that provide the telecommunications services that provide the driving forces for the opportunities discussed in this report. They were able to supply information about applications of their services. They are knowledgeable about the opportunities that their telecommunications services create, and this information was extracted. A copy of the vendor interview guide is shown in the Appendix.

Ten large users were interviewed to obtain their thinking about these opportunities. The interview guide for those discussions is shown in the Appendix.

Trade literature and product literature was also scrutinized. Trade literature was very important because it showed the importance of new developments as judged by others.

The basic philosophy of this report is to look for significant opportunities that INPUT clients can take advantage of during the next few years. Thus, if the technology or telecommunications service was very new or was "a boutique service," it was judged not to represent significant opportunities during the next few years.

F

Purpose

The purpose of this report is to seek out and report opportunities for vendors in the network processing and related markets.

The vendor interviews and analysis provide opportunity suggestions.

The user points of view provide information about what is necessary to realize these opportunities.

G

Related Reports

Interested readers are referred to the following related INPUT reports.

Network Integration, 1987: describes developments in the integration of voice, data, graphics, and image information in large companies. Case histories show how companies are changing their networks. There are a quantification of the opportunity and strategy discussions for market participants.

Network Services Directions, 1986: Describes opportunities in the area of network services. Extensive user interviews were performed for this report. Included are descriptions of technology trends and a competitive analysis of participants.

LAN/CBX: Planning for Change, 1986: Reports current experiences with data and data/voice communications technologies and looks at the future of office-oriented communications devices.

Federal Communications Market, 1986 - 1990: Covers the telecommunications systems and services programs listed in governmental five-year plans, related federal agency long-range processing plans, and information technology budgets; provides an analysis of issues impacting vendors selling into this market; and forecasts agency expenditures.

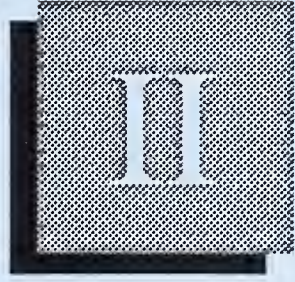

Executive Overview

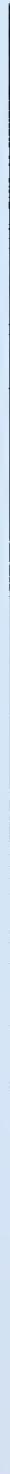

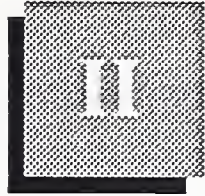

Executive Overview

A

Emerging Telecommunications Services Cover a Wide Range of Technology

The emerging telecommunications services that are discussed in this report cover a wide range of technology (Exhibit II-1). The exhibit shows that there is a great deal of activity involving different technologies in the expanding telecommunications marketplace.

- Radio transmission is represented by Small Aperture Satellites (VSAT) and by Data Transmission by Radio. In both cases the transmission medium is not physical and allows telecommunications to reach locations that were not easy to reach before. Examples are:
 - Moving vehicles.
 - Temporary locations, such as construction sites.
 - Locations that are expensive to reach, such as mines and lumber camps.
- Satellite transmission is also a natural way to economically implement star networks over large geographical areas. Radio transmission with a central repeater can be used for a star network in a small geographical area.
- ISDN and T1 services are new transmission methods combined with new standards. T1 has become very important because fiber optics have greatly decreased the unit cost of transmission. ISDN is one of the most ambitious standardization efforts ever attempted. If it is successful, and it appears that it will be, there will be many opportunities for new ways to use telecommunications.
- Gateways from local bell companies, EDI, and Advanced Message

EXHIBIT II-1

**EMERGING TELECOMMUNICATIONS SERVICES
COVER A WIDE RANGE OF TECHNOLOGY**

- Small Aperture Satellites (VSAT)
 - Satellite Technology
- Integrated Services Digital Network (ISDN)
 - Land Line Transmission for transmission on twisted pairs
- Advanced Message Services
 - Processing
- Gateways from Local Bell Companies To E-Mail and Data Bases
 - Processing
- T1 Services
 - Modulation, Switching
- Electronic Data Interchange (EDI)
 - Processing
- Data Transmission by Radio and Cellular Telephone
 - Radio Modulation

Services are primarily software applications, and offer opportunities to vendors skilled in user applications.

B**Users Find the
Emerging
Telecommunications
Services Important**

These new services are not just "interesting curiosities." They represent major opportunities for vendors and large investments for users.

T1, VSATs, EDI, and advanced message services are all very important right now. Exhibit II-2 summarizes the users' feelings about some of the emerging services.

EXHIBIT II-2

**USERS FIND THE EMERGING
TELECOMMUNICATIONS SERVICES IMPORTANT**

- Familiar with Most of Them
- Already Using VSATs to Communicate from Headquarters to the Field, for Data Interchange and Video Distribution
- Mostly Studying ISDN, but Consider It Very Important if Its Promises and Economics Are Met
- Advanced Message Services Very Important for the Corporation but Often Handled by Message Centers and End Users
- Not Particularly Excited about Gateways by Telcos to E-Mail and Data Bases
- Consider T1 Particularly Important for Corporate Networks
- EDI Is Extremely Important
- Don't Know Much about Transmission of Data by Radio and Cellular Telephone, but Believe There Is Value

- T1 has become the backbone of most large telecommunications networks because of its great economic advantages.
- VSATs provide unique communication opportunities for hub situations, such as retail headquarters to stores, and hotel chain headquarters to individual properties. Satellites (by definition) are best for "one to

many" communications. The small-aperture antennas are much easier to install than previous larger antennas. This has removed one of the major barriers to satellite transmission.

- EDI greatly improves document transfer for business transactions. The problem is a large one, and success has been demonstrated in many places. There is a great deal of interest in EDI.
- Advanced message services implement business communications in a fast and effective manner. Often the telecommunications department is not involved, and the services are sold directly to end users and message centers. There are many successes of advanced message services, and advanced message services are becoming increasingly important for intercompany usage as well as intracompany communications.

ISDN and Gateways have just been introduced, so there is not much usage yet.

- ISDN will be particularly important as its standardization spreads. The very strong dedication of the Telcos to ISDN and the intrinsic value of ISDN will ensure that happens.
- Data by radio and cellular will solve many unique applications needs, and will grow in importance as it is understood and as cellular grows. It is not used in any great amount now, except by some companies, such as Federal Express, which transmit data by radio to each truck.

C

Vendors of Emerging Telecommunications Services Don't Understand the User Needs

Vendors of emerging telecommunications services only know their own service. This lack of knowledge extends to the product managers in large telecommunications companies, as well as the market managers in companies dedicated to only one particular service. Exhibit II-3 summarizes the vendor's perception of their user's needs.

- When interviewed, the market managers were only able to comment on their own services.
- They also stated that they were not familiar with user applications and often had problems in finding users with the particular applications needed for their offerings.

The significance of this lack of knowledge is that it creates opportunities for companies that do have the applications knowledge (INPUT's clients).

EXHIBIT II-3

**VENDORS OF EMERGING
TELECOMMUNICATIONS SERVICES DON'T
UNDERSTAND THE TOTAL USER NEEDS**

- Only Know Their Own Services.
- Were Not Able to Comment on Any Other Emerging Services.
- Think There Are Opportunities for Outside Firms to Design and Build Networks for Users, Using Their (the Vendors') Telecommunications Services.
- Will Cooperate with Outside Firms.
- Do Not Think All Telecommunications Departments Are Knowledgeable about Emerging Services.
- Think Outside Firms Should Be a Solution Provider, Know Networks, Software, and Applications.
- Believe in Applications Selling, but Don't Think They (Emerging Service Vendors) Know the Applications. Expect Outside Firms to Know Applications.

- In particular, companies that have applications knowledge supply processing services, network services, professional services, and electronic information services, and therefore they have many new opportunities.
- The vendors of emerging services recognize their own lack of applications knowledge and seek to work with firms that have this applications knowledge.

D**Users Want Help from Outside Firms**

Users have skills in handling standard communications products and products similar to them, such as T1. See Exhibit II-4 for some summary comments of the users contacted.

EXHIBIT II-4

USERS WANT HELP FROM OUTSIDE FIRMS

- Mostly Want Help Where They Don't Have Skills or Staff Located
- Emerging Services where Help Is Wanted: VSAT, ISDN, Advanced Message Services, EDI, Data by Radio
- See Need for Design, Development, VANs
- Don't Think They Need Help for T1 or Gateways
- Need Help to Design and Install Away from Headquarters

They don't have skills in the areas of communications services that require software and applications skills, such as:

- EDI
- Advanced message services
- VSAT
- Data by radio and cellular

Users also don't have skills in new or "different" telecommunications services, such as:

- ISDN

Thus, both the users and the vendors of emerging communications services agree that users need help in:

- Applications
- Software-sensitive services
- New and unfamiliar telecommunications services

E

Market Size and Growth

Emerging telecommunications services change the way in which users implement their telecommunications needs, because users will either design their networks to be able to use the emerging services, or use the emerging services directly. For example, designing a network to be able to use ISDN when it becomes available is effective planning to use an emerging service. Using an EDI service instead of conventional ways of implementing document transfer is a use of an emerging service.

Exhibit II-5 shows that the total revenue that is affected by the emerging telecommunications services is \$4.8 billion in 1987, growing at 20% AAGR to \$15.1 billion in 1993. This includes:

- Network design and installation
- Network management
- Value-added communications services
- On-line data bases

This shows that the emerging telecommunications services affect a very large revenue base and that they are very important to participants in the information services marketplace.

EXHIBIT II-5

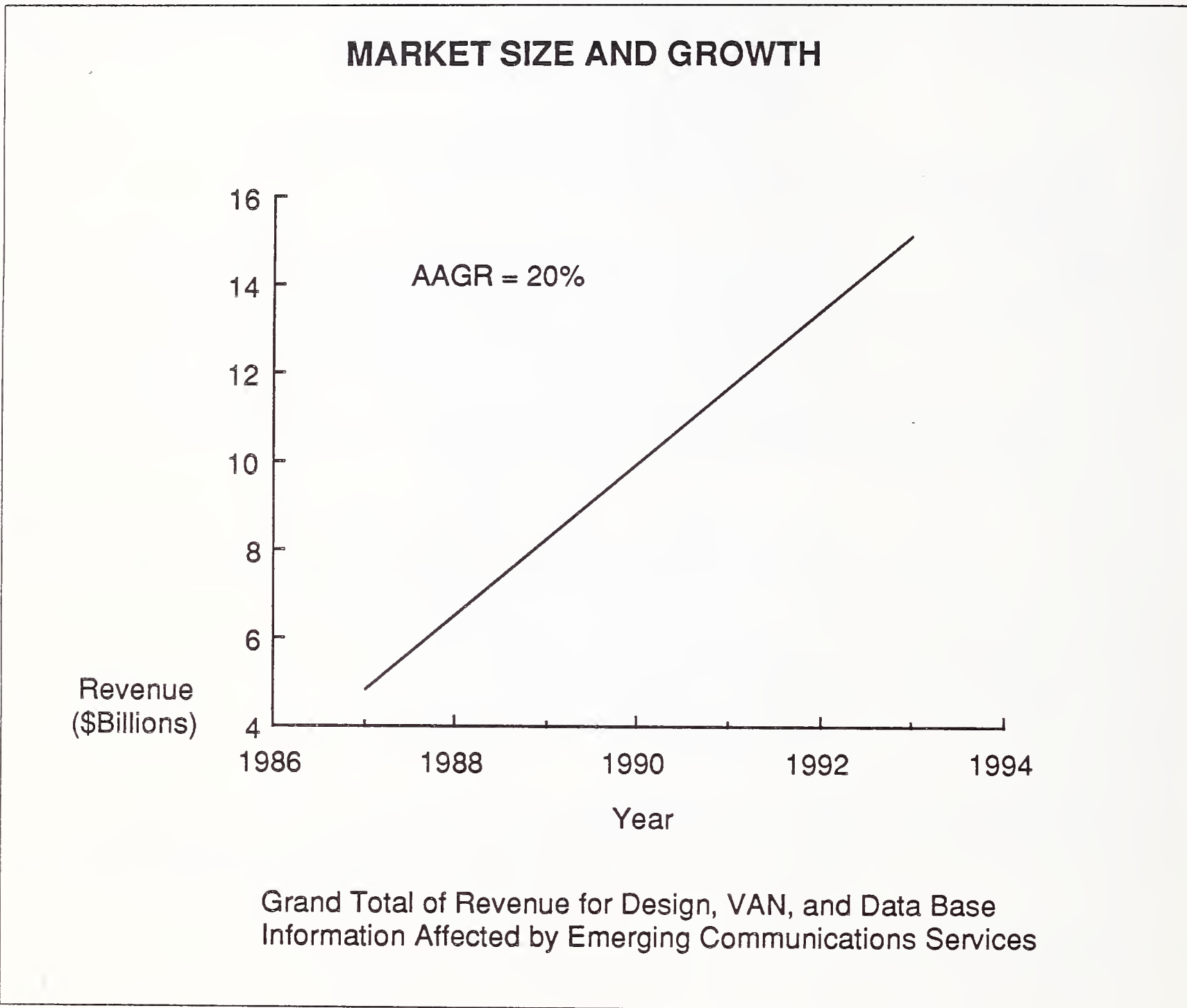

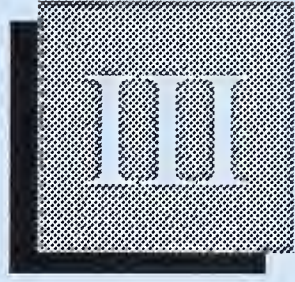

Market Definition and Forecast

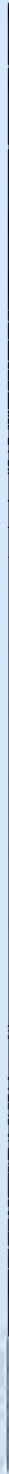

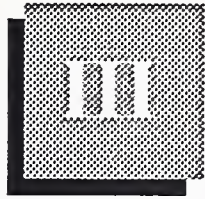

Market Definition and Forecast

A

Overview

Emerging telecommunications service developments are extremely important as driving forces toward change and opportunity for INPUT clients.

Opportunities exist to:

- Design, build, and install networks for users
- Provide communications services as a shared or public network
- Provide the information to be transported by the network—i.e., proprietary electronic data bases

Opportunities include the services (defined above) involved in directly implementing the emerging telecommunication services and the amount of services (defined above) affected because of the emerging telecommunications services.

More specifically:

- System integration projects will increase in scope because they will include the emerging telecommunications services. However, to participate in many Systems Integration assignments, knowledge of emerging telecommunications services will be required.
- Value-added network services will connect to, and also use, the emerging telecommunications services. To do this the entire network and especially its interface ports will be involved.

Proprietary Electronic Data Bases will be able to reach many more people, and also will be able to reach them with much higher data rates. Thus, the amount of information and its structure will be affected.

Opportunities have been grouped together for the purpose of the forecast, so that the entire market can be looked upon as an entity.

- Designing and installing a network for users, management of the network, and providing VAN communications services have been grouped together, because they relate to the communications service area.
- The market for proprietary data base information is defined by the INPUT market category Electronic Information Services. This category is separate from communications services because providing information is different from processing it.

Exhibit III-1 shows the relative magnitude of the impact of each of the emerging telecommunications services on other services provided to users.

- Very Small Aperture Satellites (VSATs) have a large impact on design, VAN, and processing opportunities because the earth stations are pervasive and inexpensive. VSATs are a good way to implement large geographical networks and for bypass. They have a medium effect on on-line data base services because (although they are used primarily for distribution of data) they are only one way of distributing information.
- ISDN will become a very important standard for networks and as such will have a large effect on network design. VANs will be affected because they will be able to use ISDN to offer new services such as transmission of information in ISDN format. Processing opportunities will increase as more corporate locations will be accessible at wider bandwidths and with telecommunications standards. The effect on proprietary electronic data bases is medium because it is only one way to distribute information.
- Advanced Message Services have a small effect on design and processing opportunities because they are usually separate from the main corporate networks, and are established by message communications vendors. The effect on proprietary electronic data base services is medium because although message services do distribute information and access data bases, they are only one way, out of several, to do this.

EXHIBIT III-1

HOW STRONGLY EMERGING TELECOMMUNICATIONS SERVICES IMPACT OTHER SERVICES PROVIDED TO USERS

Emerging Service	Design/ Install VAN	Proprietary Electronic Data Base
Small Aperture Satellites	Large	Medium
ISDN	Large	Medium
Advanced Message Services	Small	Medium
Gateway from Local Bell Companies to E-Mail and Data Bases	Small	Medium
T1 Services	Large	Small
EDI	Large	Large
Data by Radio and Cellular	Small	Small

- Gateways from local Bell companies to E-Mail and electronic data bases have a small effect on network design opportunities because these gateways bypass the corporate network. Processing services are not affected because they will not be connected to customers by gateways. The effect on proprietary electronic data bases is medium because gateways from Telcos are only one way to distribute information. However, these gateways could become very important, depending upon how successful the Telcos are in gateway implementation and market acceptance.

- T1 services are a very important technology to implement network integration and create network efficiency. They have a large effect on design and processing opportunities. On-line data base information is usually distributed in "smaller chunks" than T1 handles. Thus they have a small effect on the use of T1.
- EDI will be extremely important for most corporations. Thus it will have a large impact on design, VAN, and processing services. EDI does use and create proprietary on-line data bases and thus has a large impact on proprietary electronic data bases.
- Data by radio and cellular telephone is new and can do things that could not be done before. Because of its small usage now it has been judged to have a small impact on design and processing opportunities and on electronic data bases. However, data by radio and cellular is a "niche" offering, and in the niches where it is effective, it will have a large impact.

B

Forecasts

The market forecasts in this report were prepared through the use of previous INPUT forecasts and an analysis of the impact of the emerging communications services. This approach was chosen because the emerging communications services affect previously forecasted opportunities, and it is the magnitude of these basic opportunities that is relevant.

The total revenue for network design, installation, and management, and the provision of value-added communications services, which are affected by emerging communications services, will increase from \$1.0 billion in 1987 to \$5.35 billion in 1993 for an AGGR of 32% (Exhibit III-2). This forecast was generated by assuming one-third of the commercial Systems Integration forecast is logically related to communications, and combining this forecast with the forecasted revenue for value-added network services.

EXHIBIT III-2

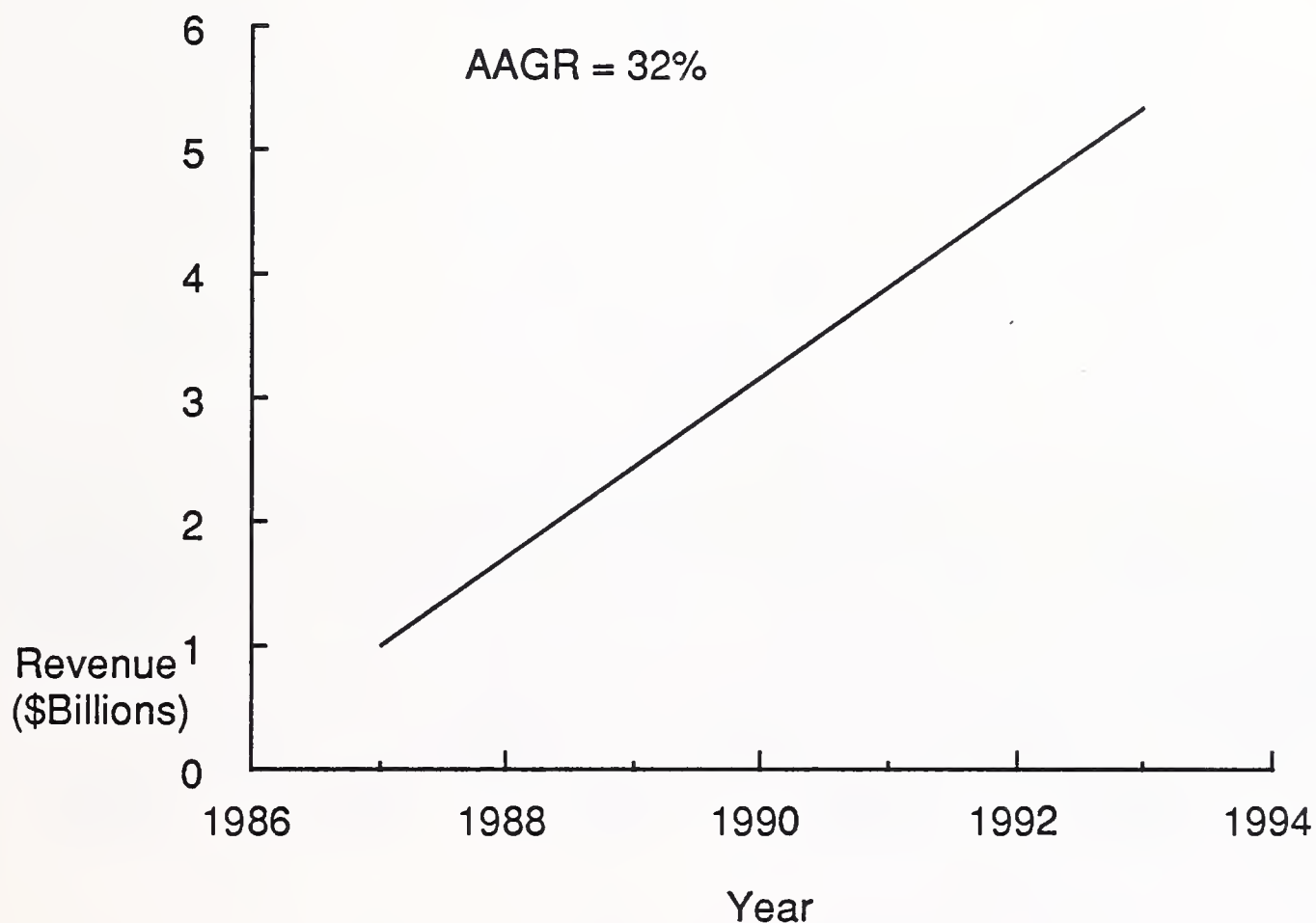
**NETWORK DESIGN, INSTALLATION,
AND VANS IMPACTED BY
EMERGING COMMUNICATIONS SERVICES—
USER EXPENDITURES**

The value-added network service forecast is by far larger than the revenue for design and management of user networks. However, these markets are all essentially specialty markets, and each vendor will/should select opportunities appropriate for its skills. The field is large enough for all, and the growth is high enough to allow new entrants.

Exhibit III-3 (included for convenience of the reader) is the INPUT forecast for On-line Data Bases, which will grow at an AAGR of 18% from \$3.8 billion in 1987 to \$9.8 billion in 1993.

EXHIBIT III-3

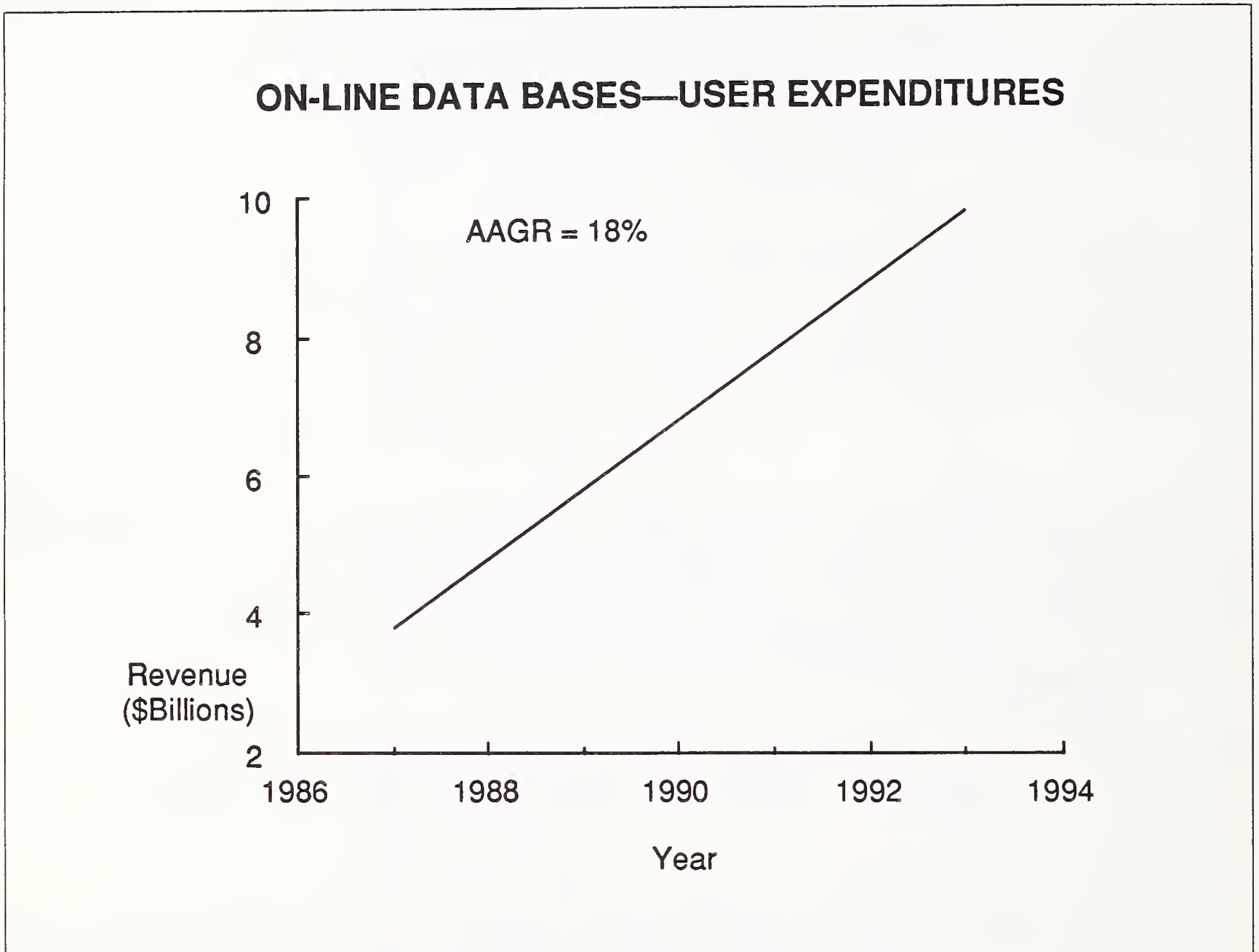

The grand total of revenue for design, VAN, and electronic data base information impacted by emerging communications services is shown in Exhibit III-4 as \$4.8 billion in 1987, growing at 20% AAGR to \$15.1 billion in 1993. This growth shows that the emerging communications services impact a very large revenue base, and they are very important to participants in the information services marketplace.

EXHIBIT III-4

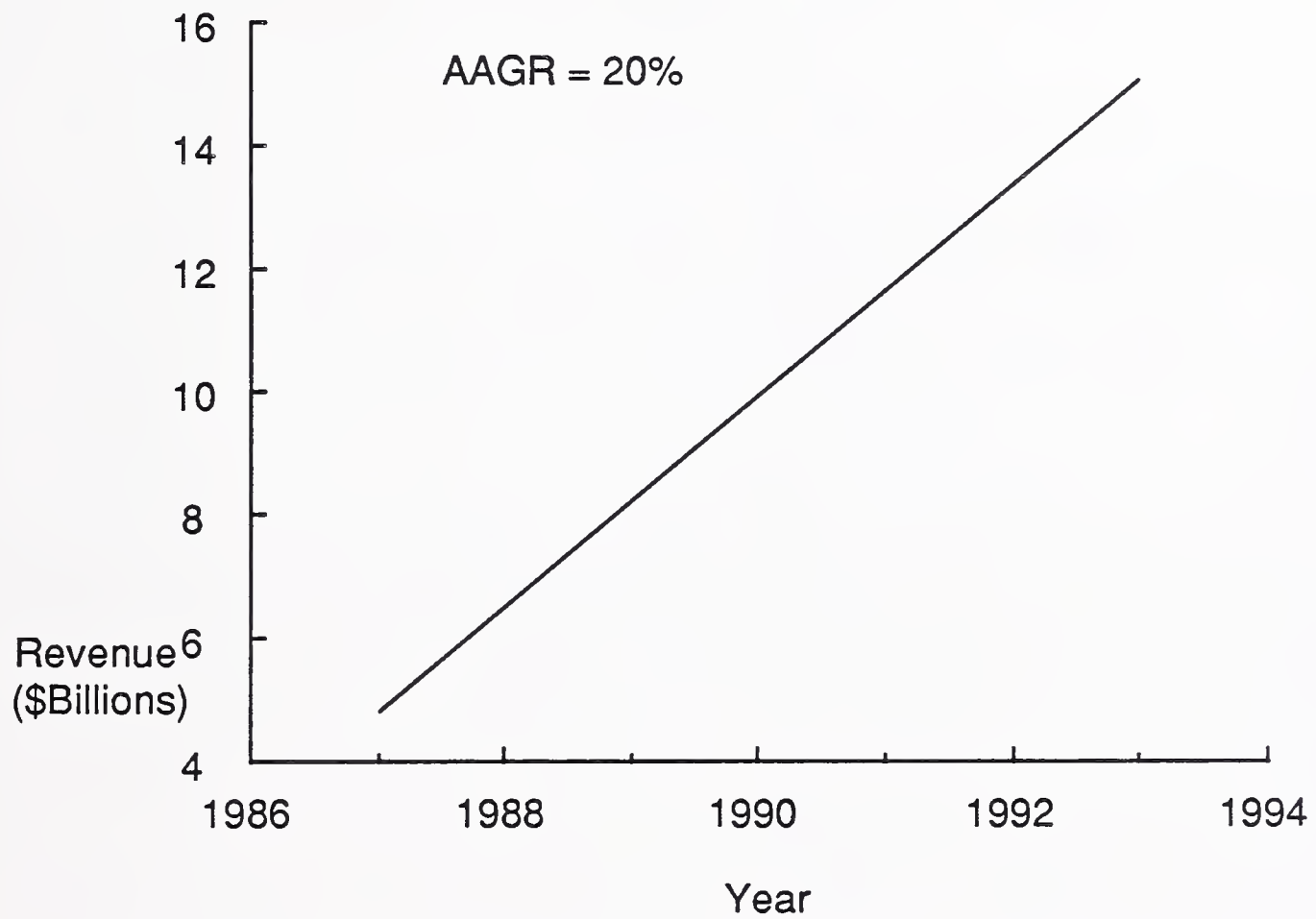
**DESIGN, VAN, AND DATA BASE
INFORMATION IMPACTED BY EMERGING
COMMUNICATIONS SERVICES—USER EXPENDITURES**



Description of Telecommunications Services and Reason for Their Growth



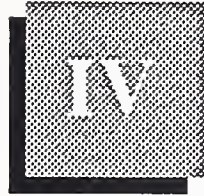

Description of Telecommunications Services and Reason for Their Growth

A

Introduction

The services briefly described in this chapter represent a significant addition to the “menu” of telecommunications offerings.

They were chosen as driving forces that create opportunities for INPUT’s clients because:

- They represent a new way of communicating and a departure from old approaches, not just an evolution.
- Each of the services discussed will be used in a significant manner. Thus, they will create large opportunities to design and provide network services. They also will provide new distribution paths for proprietary on-line data bases.
- Services that will not be implemented in a significant manner are just “interesting curiosities” for the future. The object of this report is to present to INPUT’s clients opportunities to be considered now for the next few years, not “interesting curiosities.”

In this chapter of the report the services to be considered as driving forces will be described in detail sufficient to show why they are important. In this introduction to the chapter they will be listed together with a very short description, to explain why they have been chosen for the report.

Very Small Aperture Terminal (VSAT)—VSAT services require earth stations with antennas from four to six feet in diameter at user sites. This relatively small antenna size decreases the installation and construction cost of earth stations, and also makes it easy to transport them to tempo-

rary sites. Lower cost and increased transportability makes the use of two-way satellite transmission practical at many new user sites. Thus satellite networks will become a transmission technology to be considered for many applications.

Integrated Services Digital Network (ISDN)—This is a set of standards for offerings that take advantage of new technology to greatly increase the network bandwidth and service features available to the user. ISDN is now being introduced into the field. Because of the importance of ISDN, it must be considered in any long-range network design plan.

Advanced Message Services—These services allow managers and staff in offices to communicate with each other rapidly, easily, and with graphical and hard copy information. The new communications are so different from past message services that large improvements in work performance will occur. These improvements are driving rapidly increasing use of these services.

Gateways from Local Bell Companies to E-Mail and Data Bases—These gateways allow a user to easily reach many E-Mail and data base services via a single menu from which the user chooses which service he wishes to reach and the Telco handles protocol conversions. Gateways will make E-Mail and proprietary electronic data bases available to almost everybody with a PC. In turn this will drive the growth of E-Mail and data base services and provide revenue for their further improvement.

T1—Wideband transmission services make large amounts of bandwidth available to users and decreases the unit cost of transmission. This is a driving force to redesign networks and an enabling force for network integration and new network applications.

Electronic Data Interchange (EDI)—EDI allows companies to transact business electronically (not just communicate), by allowing interchange of documents used to specify transactions such as order entry. EDI-transmitted documents fit into the corporate transaction handling system exactly. They speed the entire business transaction process and decrease its cost. It improves business and increases efficiency. EDI will move business transactions from paper to electronics and also connect more of a company's business transactions to communications.

Data Transmission by Radio—This system allows PCs and other terminals to communicate to temporary sites (construction) and to moving vehicles. In addition it is a way to distribute low-bandwidth data inexpensively. In some locations radio is more cost-effective than local loops. Data from PCs can be transmitted via cellular telephone, which allows remote use of PCs for applications such as sales transactions and receipt of emergency data bases at accident sites. The cellular telephone system then becomes a transportable (mobile) public data communications network. Data transmission by radio will create new needs for network design and new ways to distribute information.

B

Very Small Aperture Terminal (VSAT) Satellite Services

Very Small Aperture Terminal (VSAT) Satellite Services are used to distribute and collect information from remote locations spread over large geographical areas. They differ from previous satellite services in that the antennas at remote sites are relatively small (4-6 feet or fewer) and thus are easily installed and located. The small antenna size and new transmit/receive equipment have greatly lowered the cost of earth station installation at remote sites, which in turn changes the "equation" of when to use satellite networks.

Exhibit IV-1 shows the components of a typical VSAT system. The satellite operates at Ku band (frequencies from about 12 to 14.5 GHz) instead of C band (frequencies about 3.7 to 6.5 GHz). This difference in frequency (short wavelength) is what allows use of the small local antennas.

The network hub consists of a larger antenna, monitor and control equipment, and of course the customer's IS hardware. The network is controlled from the hub. Control is accomplished by the following:

- Monitor transmission to the remote locations
- Performance of remote diagnostics
- Dynamic assignment of channel bandwidth for data, voice, or video

Remote locations consist of the antenna, which can be located on the roof of most buildings, an indoor electronics unit that houses all of the control electronics, and the customer terminals, computers, etc.

The earth station equipment at remote locations is kept to a minimum-to-lower cost, eases installation, and increases reliability.

EXHIBIT IV-1

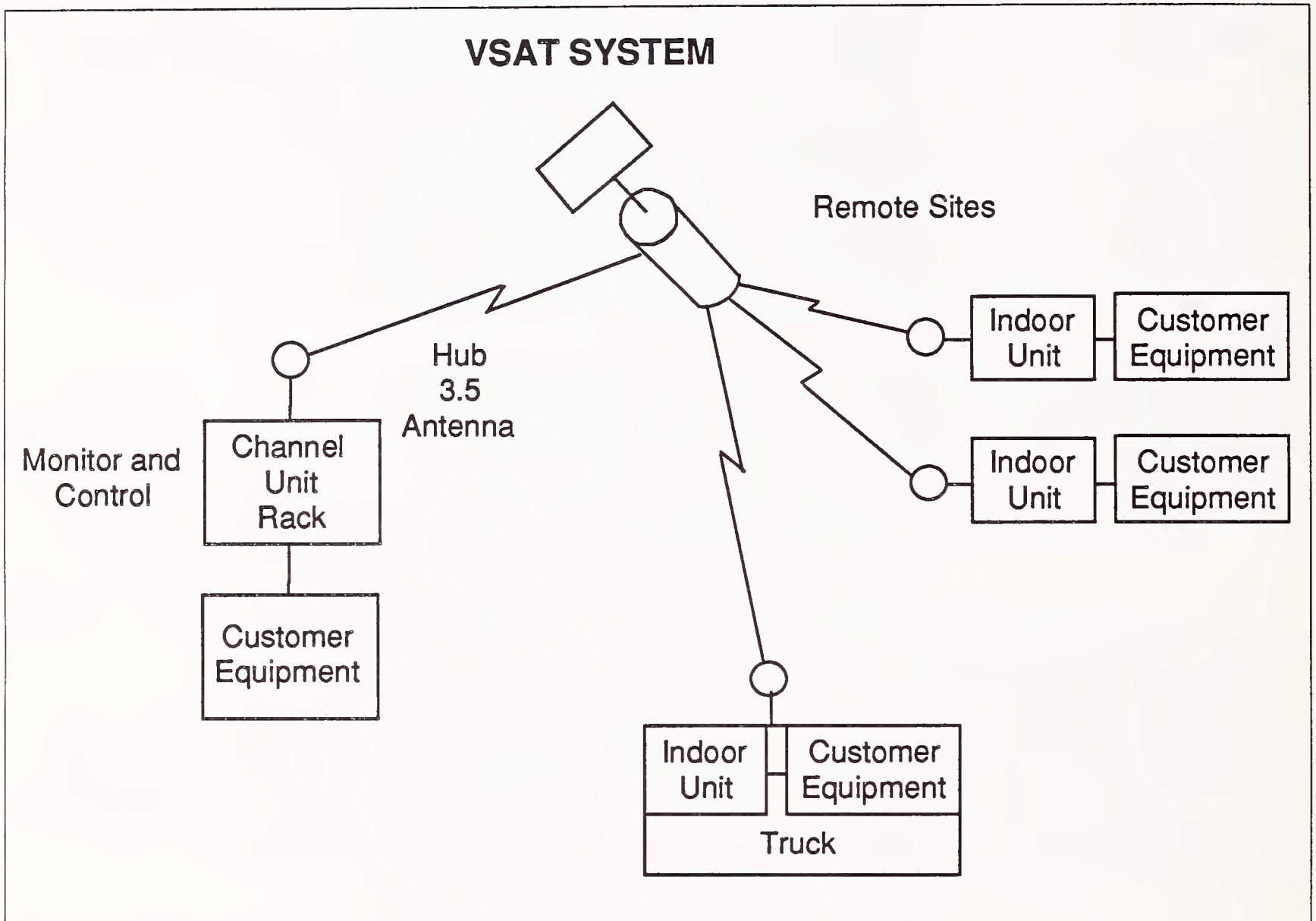

In Exhibit IV-1, two fixed remote locations are shown, and a transportable unit is shown installed in a truck. This shows the flexibility of VSAT networks. However, it must be emphasized that although VSAT technology is excellent to reach locations for which wire lines cannot easily be installed, the advantages of VSAT networks are not restricted to this type of application. The advantages of VSATs are decreased cost and increased flexibility in installation.

Advantages of VSAT satellite networks are:

- It is extremely easy to add a remote location.
- Communication costs are independent of geography and distance. This is good for geographically spread networks, but bad for local networks.

- Local loops, or interconnection to long-distance carriers, are not required.
- Reconfiguration can be dynamic to switch between voice, data, and video.

Although the prime network configuration of VSATs is a star where all transmission is to and from the hub, a point-to-point configuration between remote systems is possible.

Some typical applications of VSAT systems are as follows:

- One application is a retail environment in which about 1,500 stores handle inventory control and credit verification. The time cycles required for the application made polling on dial-up lines very difficult, and leased lines to each store were prohibitively expensive.
- Other retail applications include POS entry of customer orders, and hotel reservation systems.
- An example of transportable systems is a network for oil field data that must be remoted to large computer sites for analysis. The local sites are continually moving, so the local antennas are mounted on trucks.

Small- and medium-size companies can take advantage of VSAT systems by buying the service from a larger company or a VAN supplier. Thus they do not have to install the network hub, and only have to obtain the small remote-site equipment. This is an opportunity for network service providers.

C

Integrated Services Digital Network (ISDN)

ISDN is both a standard for communications and a communications offering. It also can be looked at as a communications channel that provides all forms of communications services (voice, data, image, and video). ISDN is different from a (non-ISDN) wideband communications channel in that it segments the bandwidth in a standard manner to allow the user to have a mixture of information communications that will be compatible with other users of ISDN.

ISDN is illustrated in Exhibit IV-2, which shows the bandwidths and channels that make up ISDN. They are the bandwidths that are available from the communications pipe, or the physical communications line that the user connects to.

EXHIBIT IV-2

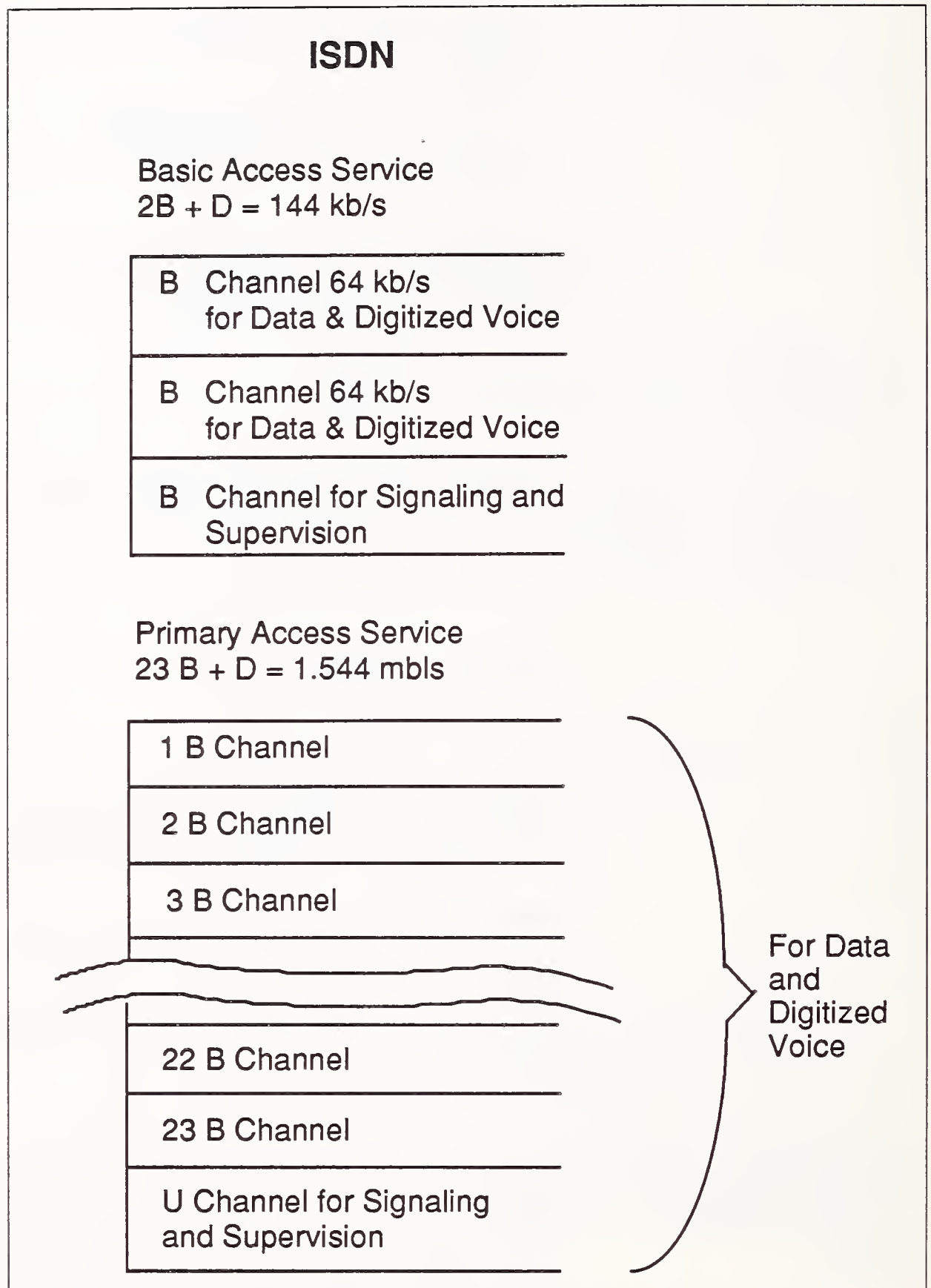

There are two “types” of ISDN—basic and primary.

- The Basic Access Service is sometimes called 2B + D. It is normally delivered on a twisted pair of wires to the user. There are two B channels, which are 64 kb/s each. They are to be used for data and digitized voice. The D channel (16 kb/s) is to be used for signaling and supervision. That is, the channel is used to inform switches and terminals

where data is to go, to make configuration changes, to start and stop transmission, etc. The D channel can also be used for data and for monitoring information. Basic access service has a total bandwidth of 144 kb/s. It can be delivered on a twisted pair. It can be switched by many new PBXs now being installed.

- The Primary Access Service (23B + D) consists of 23 B channels of 64 kb/s each plus one D channel of 16 kb/s. These channels are identical to the channels in the Basic Access Service. Primary Access Service has a total bandwidth of 1.544 mb/s, which is the same as the T1 bandwidth. It can be delivered via T1. It can also be a portion of a wide-band communications line such as a fiber optics cable.

ISDN can be dynamically reconfigured by combining B channels. For example, there may be a need to transmit video, or to transmit a large data base.

The goal of ISDN is to develop universal connectivity. The small group of standard interfaces supported for ISDN is thought of as a benefit rather than a limitation because:

- Users will be able to obtain equipment and be confident that it will be compatible with other users' equipment. They do not have to be concerned about new variations in standard ISDN interfaces making their equipment obsolete.
- Manufacturers of terminal equipment (voice, data, and video) have a reasonably small number of interfaces to design to and a large potential market to design for.

The first significant change that ISDN will make is to increase the speed of data transmission by a factor of 50 from the "usual" 1.2 or 2.4 kb/s for PCs to 64 kb/s. This will make an enormous difference for a user of data bases. For example, in about two minutes a file of about one megabyte can be transmitted. This can represent the repair manual for equipment, or a file of inventory information for use by inside sales. The amount of data in a high-resolution workstation display (graphics) is very large, and transmission of this type of information will be very significant to technical departments.

ISDN will allow simultaneous transmission of data and voice in a convenient manner. Two people can discuss data and manipulate it as if they were in the same room.

Other advantages of ISDN are:

- Separate voice and data networks will be eliminated.
- High-speed fax will allow transmission of a page in a few seconds. For one page the difference between two seconds and fifteen seconds is not relevant. However, for a forty-page contract the difference is almost ten minutes.
- Videophone (at 64 kb/s) can be sent down a B channel, which will make it easier to have videophones installed throughout offices.
- LANs can be connected to form WANs.
- The origin of a call can be observed before the call is routed to a person in a large order-entry or applications-advice department. Thus, the optimum person to answer the individual customer's call will be selected.
- Documents can be sent to a printer.
- Video conferences can be set up easily, and they can include simultaneous use of data and hard copy that is transmitted on some of the other ISDN channels.

As exciting as the ISDN standard purports to be, there still are many questions, such as:

- What are the exact standards to be used, and when will they be available?
- How will international networks be handled?
- How will ISDN integrate with SNA?
- How will ISDN integrate with satellite transmission, and handle the time delays?
- How will LANs be integrated and handled?
- How will users effect a cutover to ISDN without losing important capabilities?

ISDN is extremely important because of the way the telephone companies are “pushing it” and because of its advantages.

As important as the ISDN concept is, it is also extremely confusing to users and is believed to have a high risk if a user:

- Implements it prematurely.
- Does not plan to implement it when ISDN would have been the right decision.

D

Advanced Messaging

Messages connect people to each other. They are designed to be heard or read by people rather than by machines. As a result, messages:

- Provide some of the greatest potential for improved productivity, since they directly affect the action of people
- Are extremely visible and have a disproportionate influence on how a communications company or a communications manager is viewed.

Messages embrace very broad technologies, from basic voice and telex to voice mail, facsimile, and E-Mail. Thus, when message services are considered, the widest selection of telecommunications technologies is involved.

Exhibit IV-3 shows how message services are incorporated in companies or between companies. It makes several points.

- In large companies most messaging is internal. Large companies have their own internal message system, which can be obtained from an E-Mail service vendor, a software vendor, a computer manufacturer, or as a turnkey system. Overall, the largest quantity of messaging (and the largest quantity of all communications) is intercompany via private E-Mail services.
- Public E-Mail services connect different companies with each other. They also are used extensively to connect branches of large companies to each other. Public E-Mail services also supply compatibility for international communications.

EXHIBIT IV-3

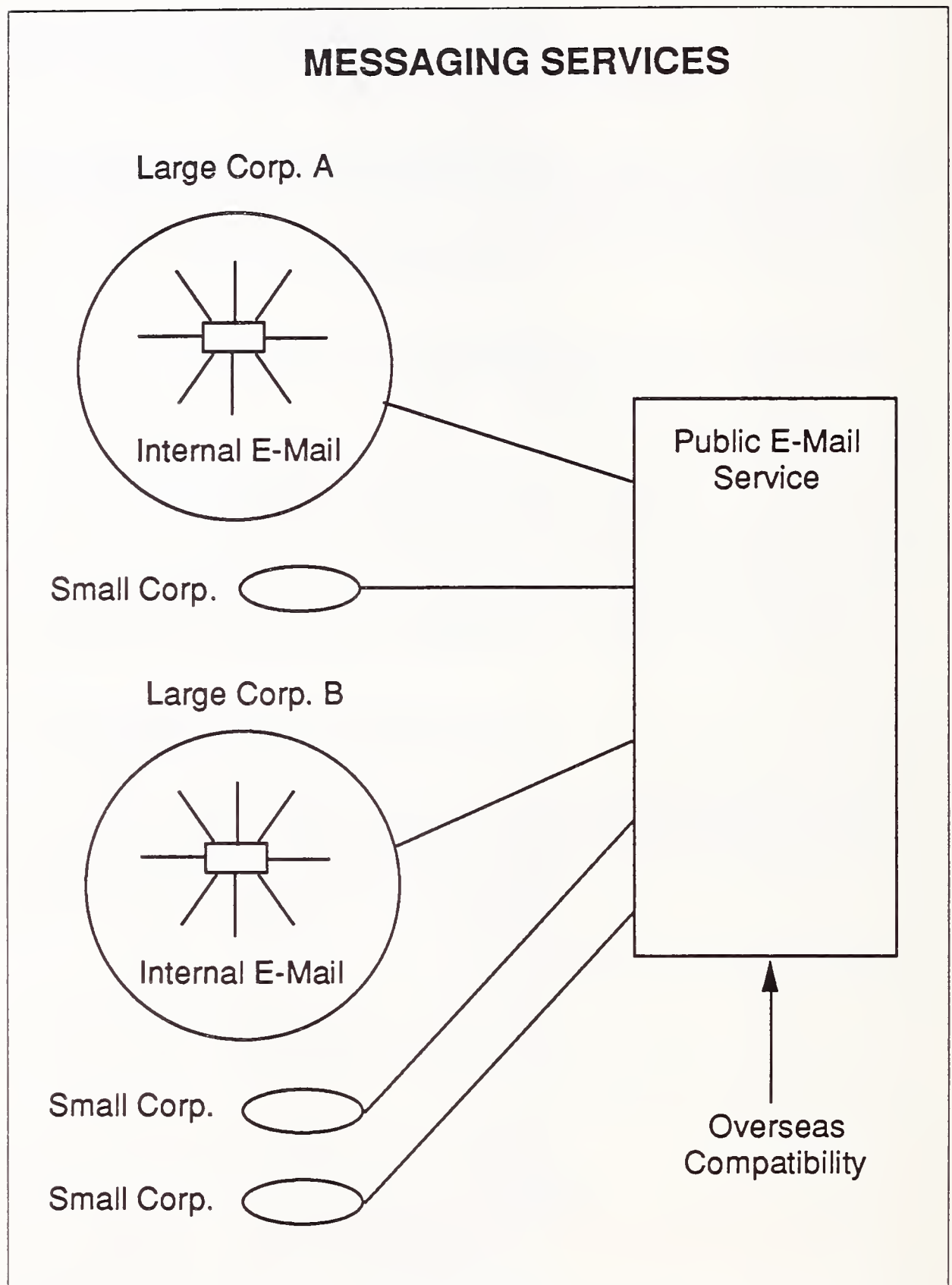

There are a whole range of advanced message services that are provided by carriers. Some of them are:

- Storing and forwarding of hard-copy messages. This service separates the transmission and receipt of a message. It allows people to pick up their messages whenever they want to and wherever they are. Salespeople with a laptop on the road and executives at home are prime examples of people who can use this service. It's the basic advantage

of E-Mail. Messages can be stored, sent to others, edited, and returned to the sender, etc., all of which enhance the use of E-Mail.

- Message systems accept messages from one type of equipment and send them to another type of equipment. This goes a long way toward solving compatibility problems. For example, an IBM PC can send a message to an Apple computer.
- It is possible to send a message from a PC to a facsimile machine. This greatly expands the flexibility of who can be reached. Facsimile messages can also be stored and forwarded. RCA/MCI, for example, has introduced this service.
- Voice can be used for messages instead of text. Voice messages can also be stored, redirected, broadcast to groups, etc. Voice Mail equipment is added to a PBX, or Voice Mail is available as a service. Thus, people who don't traditionally use PCs can send messages themselves, quite easily. Voice Mail requires no receiving terminal, just a telephone (usually a touch tone).
- Graphic information can be sent by facsimile or entered into a computer by an optical scanner and "processed" before transmission. Information such as diagrams and advertisement copy can be treated as messages.
- Standards (X.400) have been agreed upon to allow message services to be connected globally. This "translation/compatibility" approach allows people from any location and with any equipment to connect to each other.
- Plain paper facsimile is available. This will make facsimile output documents convenient to use directly, rather than "strange pieces of paper" that must be recopied to use conveniently.

The main points of all of these features and the many new features to follow are:

- Messaging extends to all types of information: voice, word processor output, data, and graphics.
- There are sufficient message features to allow anyone to do almost anything he or she wants to.

E

Gateways from Local Bell Companies

Local Bell Companies are planning to offer gateways that connect their subscribers to data bases and E-Mail systems.

Gateways are illustrated in Exhibit IV-4. On the left side of the exhibit are PCs, terminals, and computer systems. The right side of the exhibit shows E-Mail systems and data bases. The concept is that a subscriber to the local telephone company will be able to access any E-Mail service or any data base. The Telco will provide compatibility and even billing.

EXHIBIT IV-4

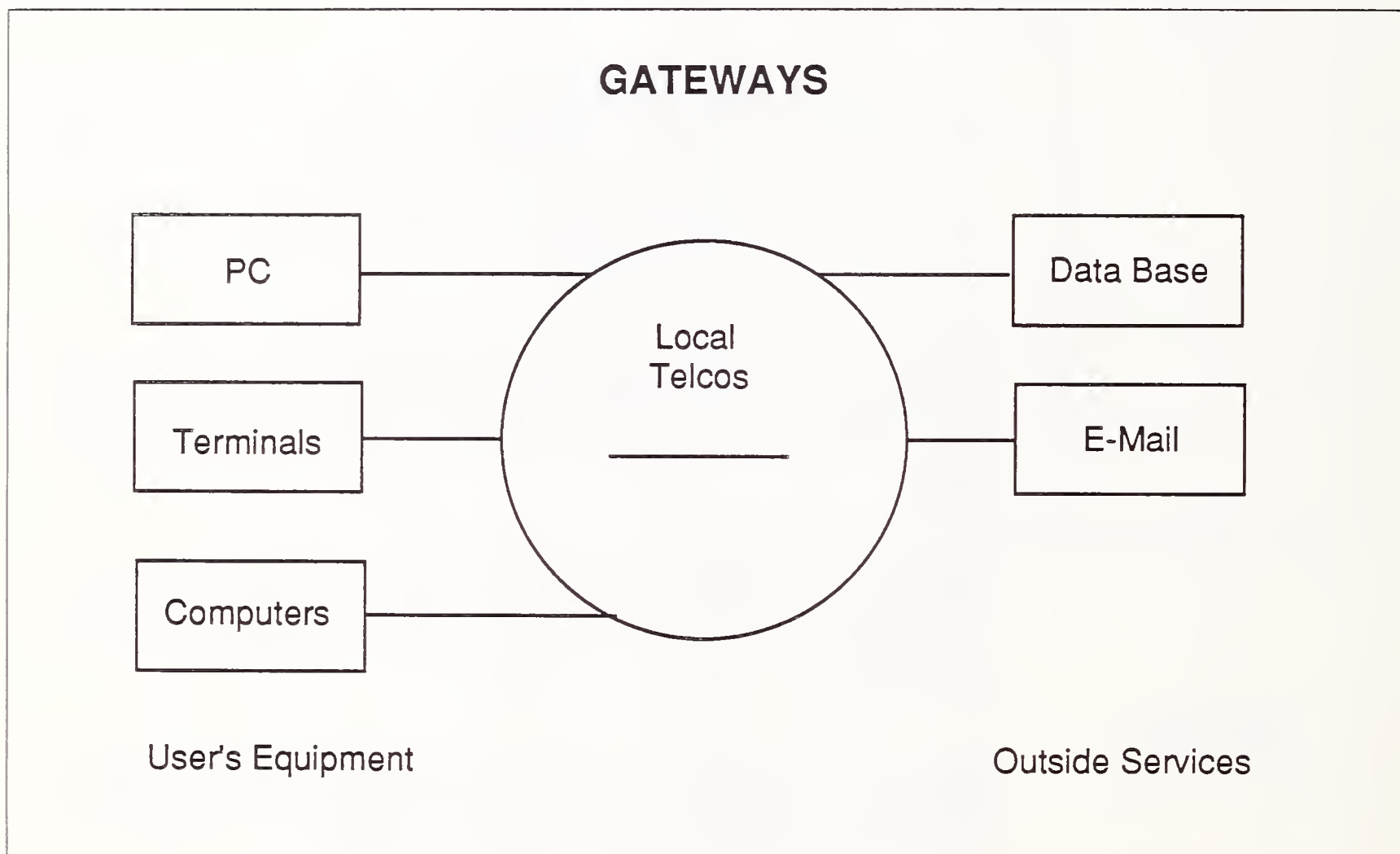

This should make it very easy for any PC or computer user to reach any information he or she wants. Depending on how well these services are implemented, ease of access to information and E-Mail will be greatly improved for the average user.

The Telcos bring subscriber coverage to the market. Everyone is connected to the Telco. Thus, if the services are well implemented, the following should likely occur:

- Subscribers can reach any of the information providers they wish to reach. In theory this should increase the market potential for information providers. Depending upon what the Telcos offer to ease access to specific information, the information providers may compete more by the information they offer than by the ease of access to their data.
- E-Mail services will be more accessible. Again this should increase the market for E-Mail. Again the competition may shift from ease of access and ease of use to competition by price and perhaps features. It depends upon exactly what the Telcos will offer. Most E-Mail services offer access to information bases, and this might be in competition with the Telcos offering access to proprietary electronic data bases.

F

T1 Wide Band Transmission Services

T1 is transmission at 1.544 mb/s. This is the equivalent of 24-voice-frequency (VF) channels, at a minimum. It is usually implemented on leased lines. However, switched T1 services are available.

T1 has become very popular recently because:

- It is economical; for the cost of only 6 to 8 leased VF lines, a T1 line can be obtained. Essentially 16 to 18 VF channels are obtained "free."
- It allows for growth in data communications without having to obtain new lines, thus saving reconfiguration expense and installation time.

Some of the uses of a T1 system are shown in Exhibit IV-5. The left side of the exhibit shows three separate facilities, each with user equipment connected to a multiplexer located on its own facility. The assumption is that the individual facilities do not have enough traffic to warrant a T1 circuit. The multiplexer outputs are then transmitted via a Telco to a T1 multiplexer.

- The point to emphasize here is that the local Telco transmission and its local loops are part of the network. Thus reliability and quality for each individual signal are a function of the Telco.

The signals are combined into a T1 channel by the T1 multiplexer. However, two alternate T1 channels to connect the two T1 multiplexers are shown to illustrate the use of two separate (T1) paths for reliability.

- With all of a company's communications information located in one T1 pipe there is a great deal of efficiency. There is also the potential of

EXHIBIT IV-5

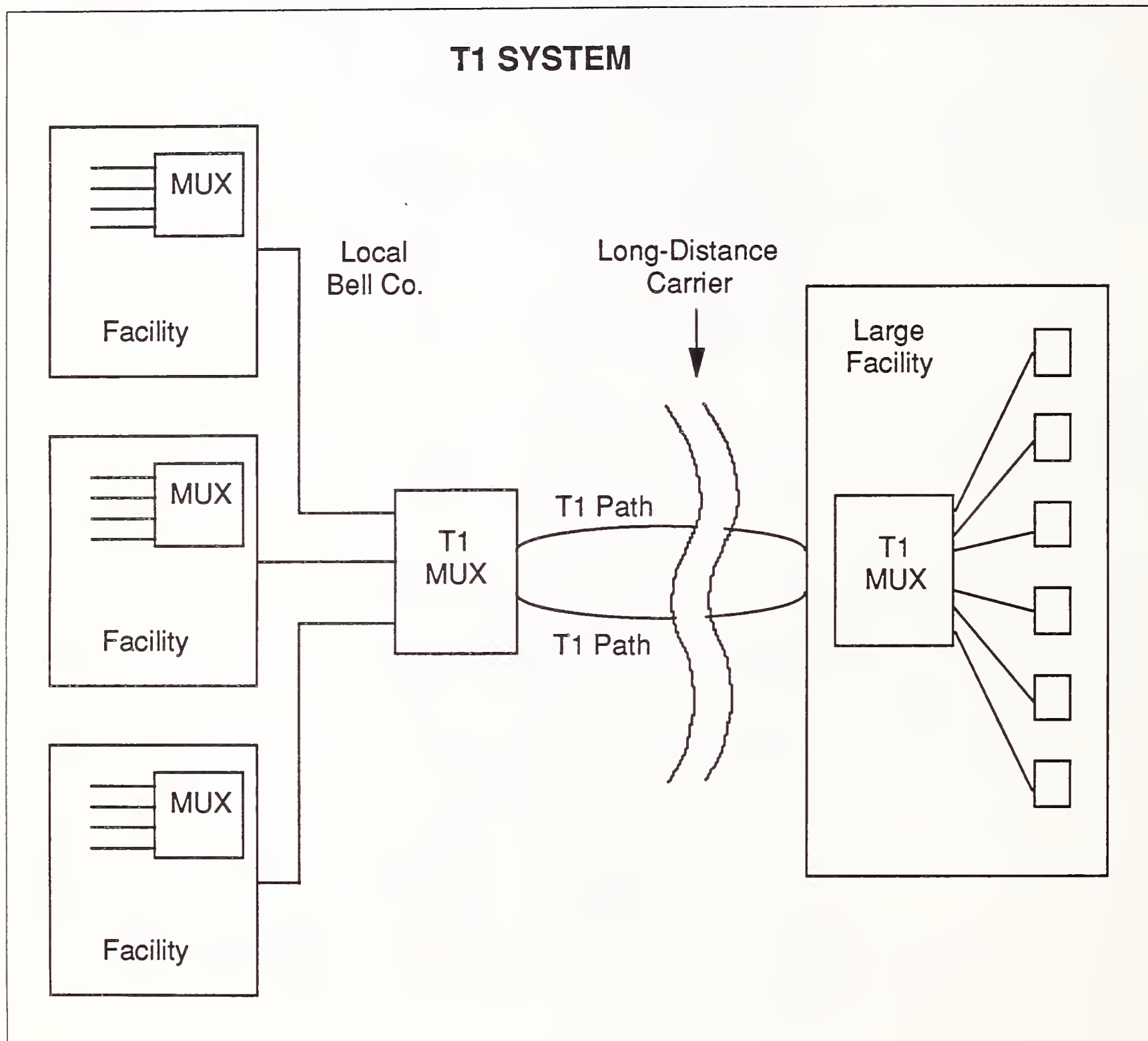

absolute disaster if that T1 pipe were to fail. Thus, there is an alternate channel shown, and the multiplexers will be designed in a “hot standby” manner so that no information will be lost in case of failure.

- This particular network example shows that the price of reliability is two T1 lines instead of one. Of course in a large network of multiple T1 lines alternate routing in case of failure is not too expensive. Nevertheless, the price of reliability is often a loss of efficiency.

The right side of the exhibit shows a facility that is large enough to have a T1 multiplexer located in the facility. In this case the Telco with its local loops and potential for circuit noise can be bypassed.

- The advantages of bypassing the local loops include cost savings, improved quality, improved reliability, convenience in making changes, and ease in fault location.

There are many issues in the design and management of a T1 network. The existence of these issues provides an opportunity for information processing and professional services companies.

Some of the issues are:

- How voice networks should be combined with data networks. They are located differently, and the administration of the voice and data networks has been historically different.
- How temporary requirements for wide bandwidth for video and large data base transport should be managed.
- What to do about planning for future growth.
- What to do about ISDN.
- How to use satellites effectively.
- Building reliability into the network without losing its efficiencies.
- Internal and local distribution of signals derived from a T1 carrier.

Without a doubt T1 is here and growing. Its advantages will make it happen. These advantages are summarized below:

- Cost savings
- Better-quality circuits
- Ease in growth to add new data lines
- Potential compatibility with ISDN
- Easier to diagnose faults in a digital network

G

**Electronic Data
Interchange Services
(EDI)**

INPUT defines EDI as the electronic transfer of business information between organizations in a structured application. The information represents standard business documents, such as purchase orders. EDI techniques are also used for other applications, such as health insurance claims.

- EDI is a more advanced form of order entry but goes beyond this first step of the buying and selling process.
- EDI commonly involves the transmission of data in one of several standard formats, with ANSI X.12 the dominant standard. It may be necessary for data to be translated to a standard either prior to transmission by a third-party service acting as an intermediary in the transaction. It also may be necessary for the data to be translated again into formats recognized by a trading partner's computer.
- The reasons for using EDI include the time value of information, cost avoidance, better inventory control, and benefits realized through the integration of EDI data and corporate information processing.
- EDI can be accomplished in several ways: point to point, directly between trading partners on private networks, or through third parties—Remote Computer Services (RCS) or Value-Added Networks (VANs) that provide translations between dissimilar processing systems and formats. VANs and RCS firms also serve as collection and switching services.

Exhibit IV-6 shows the role of VANs and RCS companies in EDI.

- The exhibit describes the participants in the business environment of EDI as Buyers, Suppliers, and Financial Service firms.
- Communication and communication value-added tasks include processing, translating, mailboxing, and switching. VANs and RCS companies both can participate in these solutions.
- VANs provide the communications links for data transmission on a dial-up basis, on a dedicated basis, or by providing private networks. VANs also provide format, protocol, and speed conversions.
- RCS firms have a similar role to VANs except that they usually do not operate their own networks. Instead, customers use a VAN, direct dial-

EXHIBIT IV-6

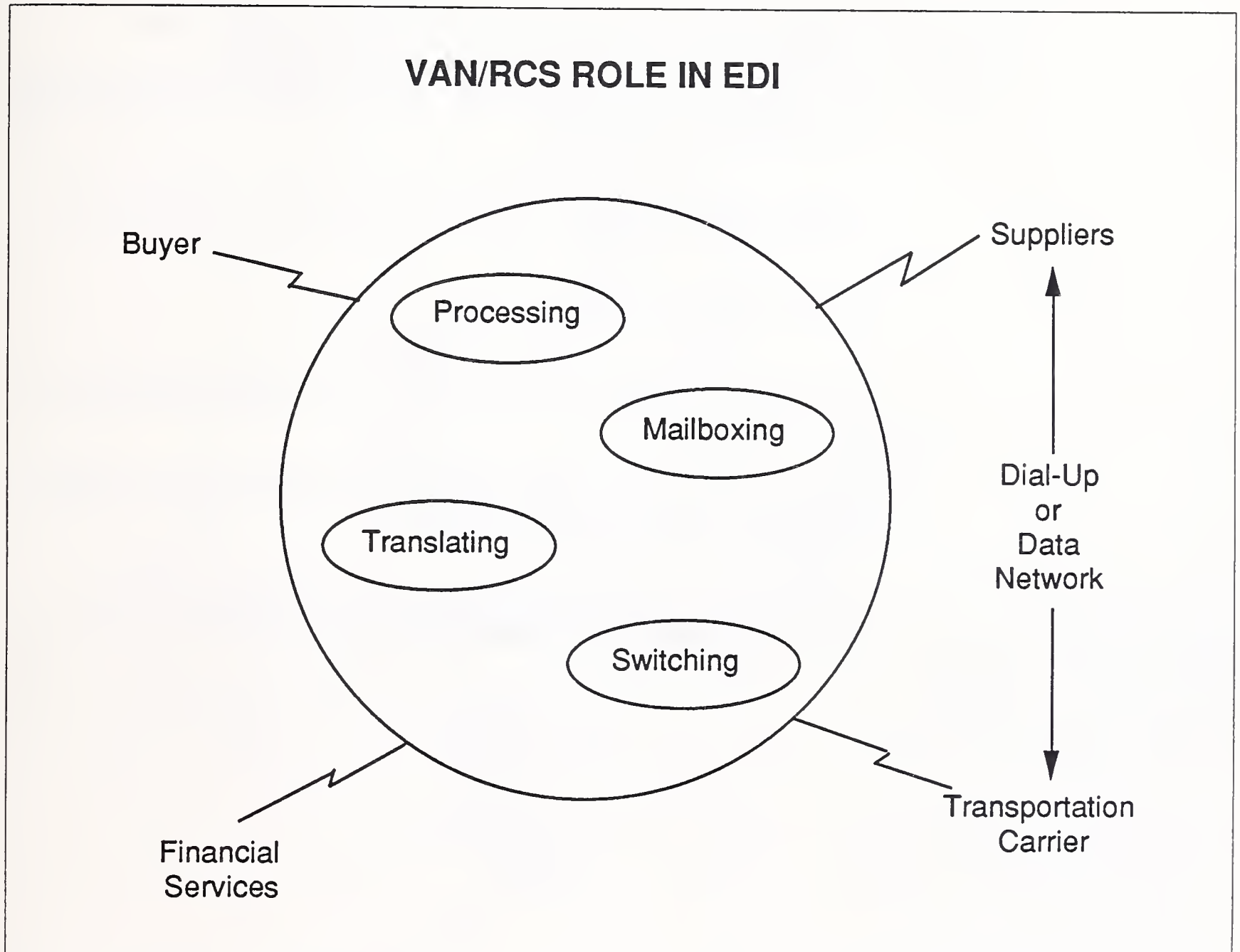

in, or an 800 number. Alternately, customers can supply computer tapes for conversion.

H

Data/Message Transmission by Radio

Because of the worldwide trends toward deregulation of the radio spectrum and because of the emergence of new technology, there is a strong trend toward new uses of the radio spectrum. One of these trends is the use of radio to transmit and receive digital information (i.e., data/messages).

Advantages of the use of radio rather than wire lines for data communications are:

- It is often less expensive.
- Transmission can be as good as or better than on wire lines.
- Networks can be installed in areas where wire lines may be impractical or prohibitively expensive.
- There is shorter installation time for new terminals because no lines have to be run.
- It can transmit to mobile locations.
- It can use new transmission networks, such as cellular telephone, for data transmission.

There are many unique ways in which radio communications are used. For examples in this section of the report:

- Exhibit IV-7 shows data transmission via a central repeater master station (something like a satellite, only by radio).

EXHIBIT IV-7

HOST TO REMOTE DATA NETWORK BY RADIO

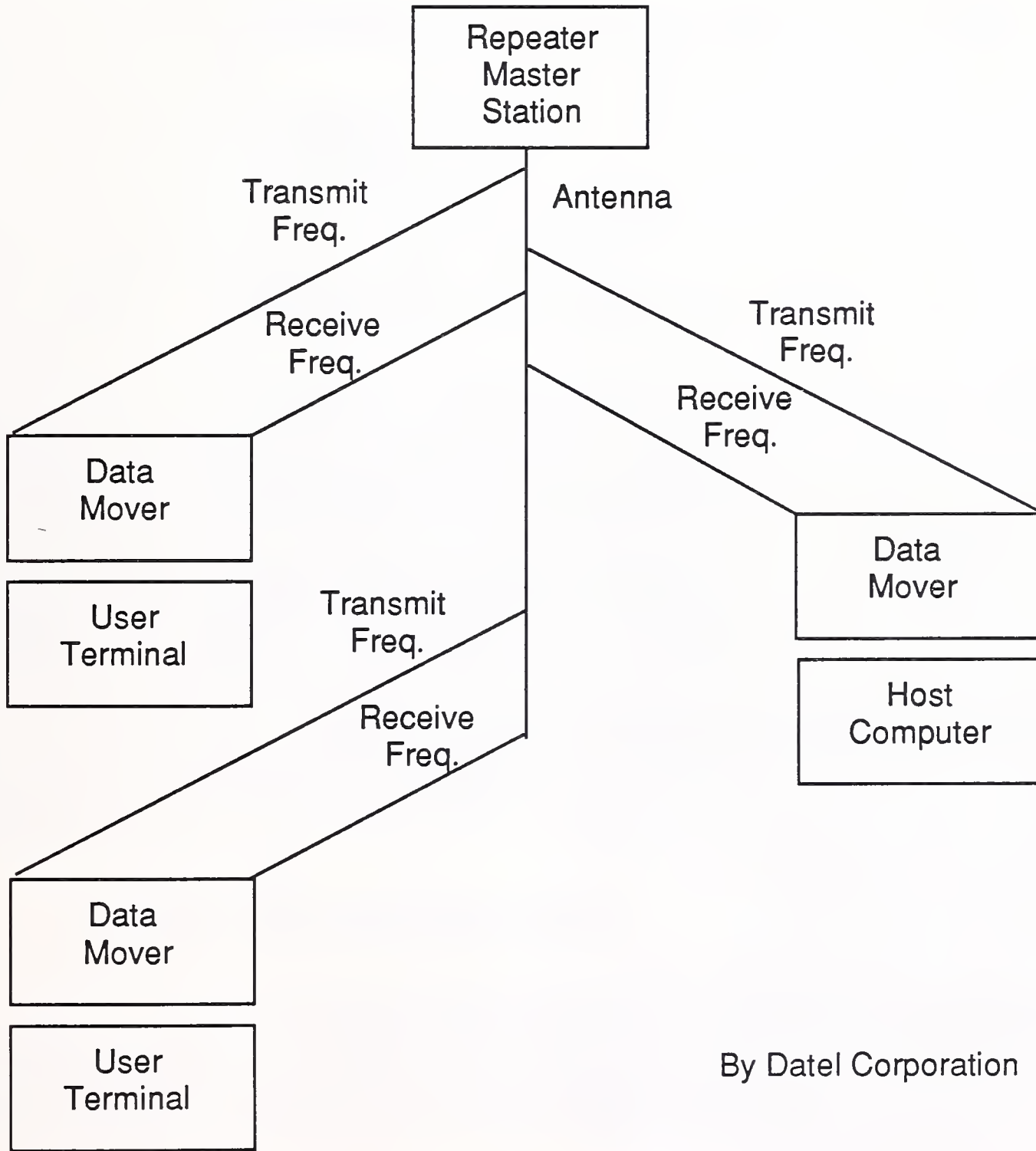

By Datel Corporation

- Exhibit IV-8 shows data/message communications by use of the cellular telephone network.

EXHIBIT IV-8

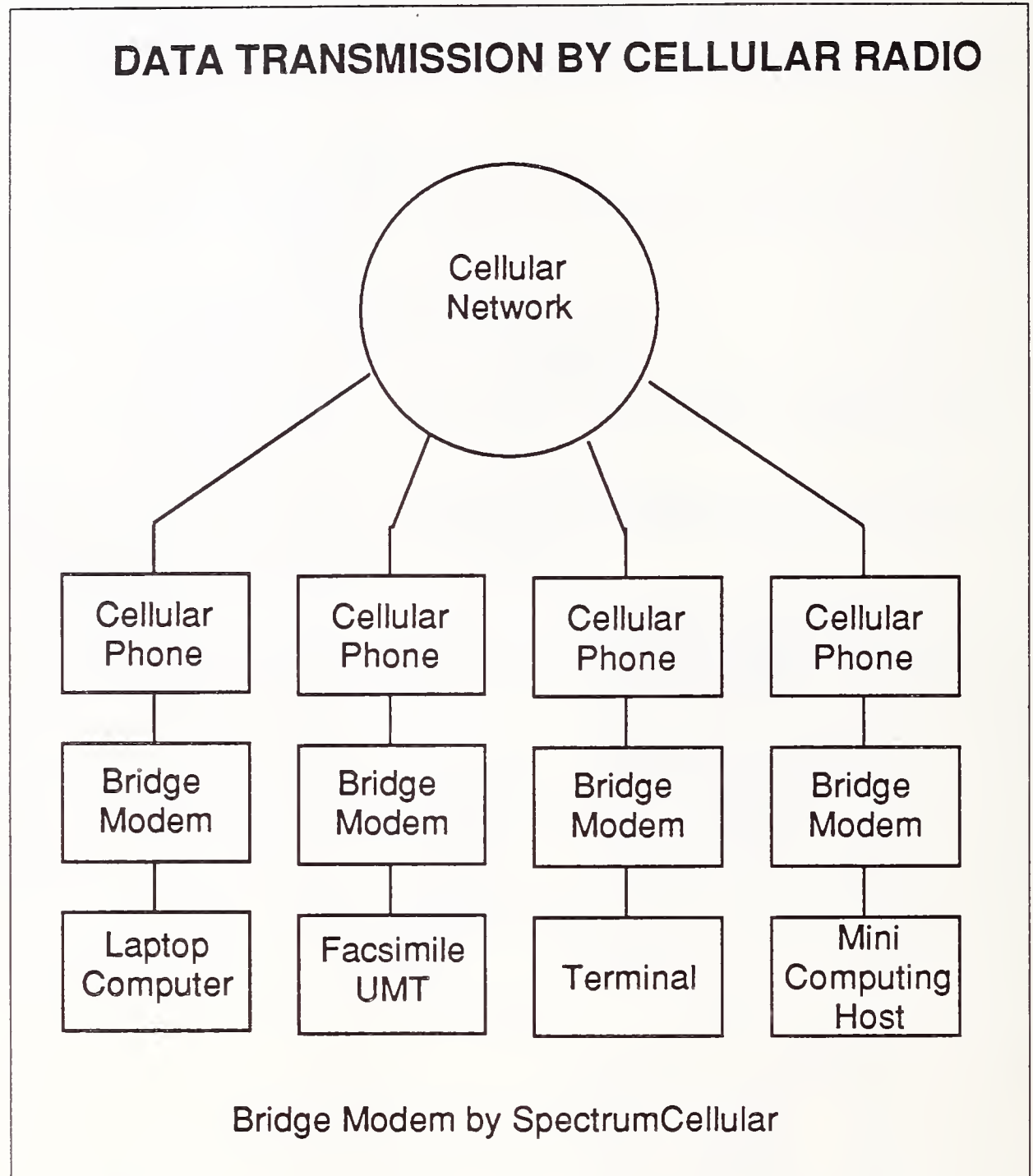

The host to remote data network (Exhibit IV-7) uses the equipment offered by Bydatel Corp. of Buffalo NY as an example. In this system Bydatel Data Movers connect user terminals to the radio network.

The data mover product has the following features:

- It uses X.25 packet switching techniques.
- It automatically senses the protocol used by the data equipment.
- It provides forward error correction.
- It can provide encryption.

- It operates in synchronous and asynchronous environments.
- It can handle 225 terminal locations on a single network.

Exhibit IV-8 shows how the cellular telecommunications networks installed for telephone usage can be used to transmit and receive data.

In this example a Bridge modem provided by SpectrumCellular in Dallas, TX is shown connecting via cellular telephones:

- Laptop computers,
- Facsimile units,
- Data terminals
- And the central host computer.

Some applications of this system are:

- Connection to computers at construction sites in hard-to-reach areas
- Reception of hazard information at chemical-spill or fire sites by means of facsimile
- Sales data entered from the field
- Routing information for trucks
- Availability of data base information in the field, including the ability to search the data base
- Etc.

The Bridge modem:

- Is designed primarily for mobile or remote use, where land communications protocols and error correction techniques will not work
- Provides auto answer and auto dial
- Provides 1,200 baud or 300 baud communications
- Can be used for mobile-to-mobile communications or mobile-to-host communications
- Works with facsimile as well as computers



The User Point of View

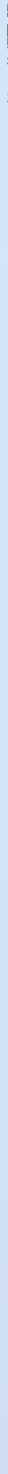

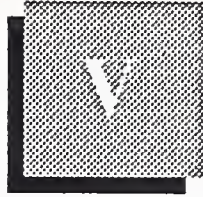

The User Point of View

A

Introduction

This chapter of the report presents the point of view of users toward the emerging telecommunications services and toward the opportunities these emerging services will provide for INPUT's clients.

Senior members of the telecommunications department staff in ten Fortune 500/50 companies were interviewed (please see user questionnaire in the Appendix). These interviews were open ended to obtain the thinking of the respondents.

- Although there were too few interviews (10) for statistical rigidity, the patterns of thinking of the respondents are clear.
- This chapter explores the significance of the respondents' thinking. Attention is paid to areas where the respondents were not familiar with the services, as well as areas where they were familiar with them. There are important opportunities for INPUT's clients to provide assistance when users are not familiar with an important telecommunications technology.

The comments of the respondents were paraphrased for clarity and brevity and displayed in Exhibits V-1 through V-7.

- Note that each respondent is numbered and the number of each respondent is the same in all of the exhibits. This allows the reader to follow the attitudes of each respondent with regard to each of the emerging services, as well as the attitudes of all of the respondents with regard to one of the emerging services.

Respondents interviewed are listed below by type of company, with the same numbers that are used in the exhibits.

- 1) Manufacturing conglomerate
- 2) Aircraft manufacturer
- 3) Hotel chain
- 4) Manufacturer of heavy equipment
- 5) Electronics manufacturer
- 6) Manufacturer
- 7) Manufacturer
- 8) Pharmaceutical manufacturer
- 9) Chemical manufacturer
- 10) Power utility

B

Satellites with Very Small Aperture (VSAT)

This is a technology that was familiar to most of the respondents (Exhibit V-1). They see the need for VSATs and understand their advantages. Usage will be for data and business video in a hub to field or trunking environment. Opportunities that respondents see are for vendors to:

- Design the network. It seems that VSAT is somewhat of a different technology and that users want help in design of VSAT networks.
- Help construct the network by field installation.

There is some interest in VANs providing VSAT services. The interest was limited because INPUT did not spend a great deal of time telling respondents what VANs could do for them.

There was little interest in proprietary data base distribution. This lack of interest in data bases is seen throughout the interviews for almost all the emerging services. It is most likely that data bases are of interest to specific users and not an issue of the telecommunications department.

Some of the applications mentioned by users are:

- Remote metering and load control
- Data exchange between headquarters and hotels
- Business video and trunking
- Connect to hub sales offices
- Data and video trunking
- Data now to expand to voice
- Disaster backup

EXHIBIT V-1

SATELLITES WITH VERY SMALL APERTURE

1. Currently using and consider it valuable. Good for remote metering and load control.

Sees opportunity for outside firms to provide system design (vendors do now) and offer value-added services. Currently using Equatorial Services. Possible opportunity for firms to provide data base services.

2. Sees an application for VSATs.

3. Much interest in VSATs between Corporate Headquarters and Hotel properties for data transmission.

Designs networks itself, but sees opportunity for outside firms to operate networks in the field and to provide value-added services with VSATs. Doesn't know about data bases.

4. Sees value for business video and trunking.

Sees opportunity for outside firms to design networks and help construct them. Doesn't see opportunity for outsiders to operate networks, be VANs, or provide data bases via VSAT.

5. Looking at VSATs to connect to hub city sales offices.

Does most design and network operation in-house. Does not see opportunities for VANs or data distribution.

6. Sees no value of VSATs to company and has not thought about it.

7. Has looked at VSATs but is not cost effective for company. Would use mostly for data, some voice.

Does its own design in-house but would subcontract construction. Has not considered VANs or data distribution by VSATs.

8. Uses C band now, perhaps VSATs for data and video trunking.

No longer has design capability in-house, might go outside. Sees no value in VANs or data base distribution.

9. Using VSATs in a limited way for data and will expand to voice.

Does not see much opportunity for outsiders to design and operate networks. VANs and data base distribution are another department.

10. Possible use of VSATs for disaster backup, for voice.

Sees opportunity for outsiders to design the network. Not to operate it, or become VANs.

C

**Integrated Services
Digital Network
(ISDN)**

Only one of the respondents is a real user of ISDN (Exhibit V-2), which is reasonable considering the ISDN introduction status. However, most of the respondents think that it will be of great value, depending upon final pricing, specifications, etc. ISDN is considered an important service.

- Opportunities are seen for some assistance in design of the network and more assistance in field installation. There is not a strong desire for outside help. However, it is expected that when these users actually start designing networks for ISDN, there will be more of a need for assistance.
- Some of these users see opportunities for VANs and for proprietary data. This is contrasted by the strong interest of Respondent 1, which is a large user of ISDN and the only large user interviewed.

Applications that were mentioned by users were:

- Voice, visual display, PC to PC, PC to mainframe, PC to data bases
- Backbone transmission of voice and data
- Telemarketing and automatic return dialing
- Data switching and data base distribution
- Voice and data integration
- Sales and marketing
- Nationwide networking and international for large amounts of data
- Voice and data in long haul

EXHIBIT V-2

INTEGRATED SERVICES DIGITAL NETWORK (ISDN)

1. It is the largest current user of ISDN in the U.S. and sees it as very valuable. Use for voice, visual display, PC to PC, PC to mainframe, PC to data bases.

Sees use for outsiders to design (its system was totally engineered by Telcos). Sees many possibilities for ISDN as VAN, including data base distribution, marketing, metering systems, security systems, slow-scan TV. Does not use outsiders to operate network.
2. Doesn't see much need for ISDN for company, although it is following it. It does its own design and sees no use as VANs or data base distribution.
3. Sees ISDN of great value depending on economics. Will use for backbone transmission of voice and data.

Would use outside services for design in field and construction at headquarters and in the field. Sees use for VANs with ISDN. Doesn't know about data base distribution. Perhaps operate networks for others, not itself.
4. Will have use for ISDN when it matures, for telemarketing and dialbacks for end-to-end communications.

Sees opportunities for outside firms to assist in design but not for operation of networks, VANs, or data base distribution.
5. Sees value if it does all it's supposed to. Will use to switch data and reduce number of private lines.

It does design itself with help of supplier and subcontract installation. Sees some slight need for VANs or international. No need for outsiders to operate networks, or for data base distribution.
6. Could be a great asset when nationwide. Use for voice data integration and to reduce costs.

It does design itself but subcontracts installation. Has not considered VANs or data base distribution.
7. ISDN could be of value for sales and marketing groups.

Has done most of its own design with AT&T. Sees possibility for VANs if they come up with attractive services.
8. ISDN will play a minor role, mainly in nationwide networking and international for large amounts of data.

Sees use for outsiders, mainly international, to coordinate, etc. Perhaps use for outsiders to operate international network. Not really used for VANs or data base distribution.
9. Doesn't see use for ISDN immediately. If cost comes down can use for video conferencing.

No need for outside firms.
10. ISDN of limited use for company because it is a regional company. Perhaps use for voice and data in longer haul situations.

Could use outsiders for some design and installation. Sees no need for VANs or data distribution or network operation.

D**Advanced Message Services**

This is a very important communications area to corporations (Exhibit V-3). It is interesting that the telecommunications department does not seem to manage message services in some cases. This points out the need for vendors to sell message services to users and not always to the telecommunications department. Also it should be noted how important facsimile has become.

The major conclusion from the interviews is that users have to deal with a multitude of different E-Mail and other communications services, and that the task is complex.

There is an interest in outside design and consulting services since message services are getting quite complex. There is also a perceived need for VANs.

Applications are:

- Sales orders, reports, etc.; also conversion from PC to/from fax
- Many varied applications for both fax and E-Mail
- Many applications
- Communication of customers and suppliers to the company
- Replace overnight mail

EXHIBIT V-3

ADVANCED MESSAGE SERVICES

1. Could be important to convert data to PC or fax and help eliminate paper. Use for sales orders, reports, etc.

Could use outsiders for design and implementation, and possibly for VANs. Not to operate its network.

2. Very complicated area. Has fax systems and electronic mail systems, which are very vital for the corp. Many varied applications.

Can use some consulting but not network operation.

3. Not familiar with them.

4. Handled by message center people, but does have very large fax network.

5. Currently uses MCI Mail, GE Net, and IBM Info service and others. Very valuable to corp.

Would use outsiders for system design, and VANs. Doesn't know about information base distribution.

6. Not doing anything in this area at this time. Has some potential.

7. Could be of value. Has islands of E-Mail and looking for way to bring them together.

Maybe use VANs, not outside design.

8. Always a need to provide. Trying to make it easier for outsiders to communicate with company. Wants E-Mail to fax, voice mail, the USPS, and others.

Sees opportunities for outside firms to help design and for VANs.

9. Has extensive fax network (very valuable, replaces overnight mail). Also will install voice mail.

All dial up, no need for outsiders or VANs.

10. Uses fax in a large network and looking at Fax PC boards.

Perhaps will use VANs but doesn't know of any now. No need for outside design.

E**Gateways by Telcos to E-Mail and Data Bases**

This is not a service (Exhibit V-4) that is of great interest to telecommunications managers. They find access to E-Mail (see previous section) and data bases very important. However, they have yet to be convinced of the added value of the Telcos providing gateways.

Of course in fairness to the Telcos this service has not even been tested yet and they have not yet made their case for its importance. In addition this service may be of greatest value to corporate users who don't go through the telecommunications department to reach an outside data base.

Most of the need for outside firms is to provide VAN services and gateways—this is the predominant view of the respondents.

Some applications are:

- Access medical, legal, and financial data bases
- Use for engineering services and PC applications
- Used by individuals in the firm, not corporate
- Reach outside information sources

EXHIBIT V-4

GATEWAYS BY TELCOS TO E-MAIL AND DATA BASES

1. Currently doing it another way, very valuable. Telco Gateway is just another service. Use for medical, legal, and financial data base access.

Outside firms can also build gateways and provide VAN services if innovative.

2. Very valuable idea but the defense business has its own community of interests. Not much need to expand beyond that.

No need for outsiders.

3. Not interested, perhaps in other departments.

4. Handled by message center people.

5. Doesn't see much value in it.

6. The service is of value, but not sure that the local Telcos could improve on what it (respondent) is doing. Uses for engineering services and PC applications.

Perhaps outsiders could help, depending on what they do for designs and VANs.

7. Used by individuals with their own PCs and needs. They subscribe to data bases as corporate. Not sure if the Telcos will expand usage.

8. Telcos might provide competition and come up with new services.

Sees use for outside firms to design these services, operate them for companies, and provide VAN services, all connect to other information sources and E-Mail.

9. Has no need, all systems are on a dial up basis. Use to replace overnight mail services.

10. Has some, but not a great deal of need at this time. Use for administrative services.

F**T1 Transmission Services**

T1 services (Exhibit V-5) are extremely important to the large corporations interviewed. They use them a great deal and understand them very well.

The main need for assistance in the use of T1 is to help in network design and construction. This seems to depend on where the work must be done. More assistance is required at locations distant from corporate headquarters.

- The respondents did not see any need for VANs to supply T1 services.

Applications for T1 are:

- Point to point for data, CAD/CAM and the like as example of large amounts of data
- Backbone for voice, video, data, local nets, etc.
- Voice and data integrated
- Connecting mainframes, PBXs, voice, and data
- Data trunking, FX, Telco bypass
- Voice
- Combining voice and data
- PBX tie lines, and on campus
- Data communications, and trunks to back up data centers

EXHIBIT V-5

T1 TRANSMISSION SERVICES

1. Very important and will continue to be the the main way that companies will communicate with each other, point to point. Use for data, CAD/CAM and the like.

No opportunities for outside firms. Company just orders facilities when needed.

2. Very heavily used in backbone communications for voice, video, data, local nets, almost anything you can think of.

Mostly in-house design but off-site deal with outside suppliers for design. No other help needed.

3. Makes extensive use of T1 for voice and data.

Uses Telcos and other firms to help in design and construction, depending on location. No other outside use.

4. Consider T1 very important to connect mainframes, PBXs, and voice and data.

In some areas outsiders can assist in the planning, design, and construction. No need for network operation or VANs.

5. Very useful, 30% of network, used for voice and data trunking, some FX services, some data, and for Telco bypass.

Most T1 have been engineered for respondent under subcontract with vendor. Can't think of any VAN use.

6. Doesn't have enough traffic for T1 even though company has 110 locations.

Sees use of outside firms to design and construct. Not for operation.

7. Use only 6 systems for voice. Plans to install more for voice and data.

Does design and installation with AT&T, doesn't need others.

8. Uses T1 as the backbone of its communications system, for integration of voice and data on a single network.

Does design and construction in conjunction with suppliers. Lots of problems, finding competence is big problem.

9. A very valuable service, used for tie lines to PBXs and on campus.

No need for outside help.

10. Considers T1 valuable but not vital. Uses a number of lines for data communication trunks to back up data centers. Some voice.

Some design and installation opportunities for outsiders, depending on system and location.

G**Electronic Data Interchange (EDI)**

This is also an important service to the respondents (Exhibit V-6). Most of them are either using it now or looking at it. Those using EDI are planning to expand its use.

For EDI service the respondents see a great deal of need for outside assistance. Design and development, VANs, and proprietary data base supply are all needed. This is probably because EDI involves processing information and is beyond the capabilities of telecommunications staffs, which install networks and circuits but do not process information.

Applications for EDI are:

- Purchasing, RFQ, invoicing, payment, sales orders
- Many different applications
- Supplier communications—shipment status, order entry to suppliers, etc.
- Order entry and sales
- Order taking
- Billing

EXHIBIT V-6

ELECTRONIC DATA INTERCHANGE (EDI)

1. Most divisions use, and expect use to grow. Use for purchasing, RFQ, invoicing, payment, sales orders.

Opportunities for outside firms to design and build (especially for special applications), to operate VANs, and to provide proprietary data bases.

2. Handled by another group.
3. One of the more valued services, used in message center for many different applications.

Sees opportunities for outside firms to design and operate networks.

4. Very valuable, intends to move more into this service when present contract with GE is up. Will use for supplier communications—shipment status, order follow up, order entry to suppliers, etc.

Can use outsiders to design and develop (under company's supervision), supply as VAN only if its something respondent cannot do, and perhaps provide proprietary data bases.

5. Considers it important and using it now.

There are opportunities for outside firms to design and develop, depending on what is being offered. There are opportunities for outside firms to operate networks, behave as VANs, and possibly provide proprietary information.

6. Keeping an eye on it for order entry and sales department invoicing.

Possible need for outside firms to design, develop, and operate networks. Also, to behave as VANs and supply proprietary information.

7. Involved with EDI to some extent and interested in doing much more.

Doesn't know about opportunities for outsiders.

8. Not much being done with EDI now except for fax.

Perhaps opportunities for VANs, can't think of any.

9. May use in future if company centralizes its order taking. Doesn't see opportunities for network design, development, and operation. Does see opportunities for VANs and to provide proprietary information.

10. Thinks its a valuable service. Being studied, not used, for billing applications.

Sees no opportunities for outside firms in this area.

H

Transmission of Data by Radio and Cellular Telephone

This is important to some firms (Exhibit V-7) and not to others. Respondents did not seem too familiar with the services involved, or even with the corporate need for such services. It is probably one of those services sold to specific user departments and not to the central telecommunications department.

Respondents see opportunities for outside firms to design, develop, and operate networks, as well as become VANs. Since most corporate communications staffs are not familiar with the use of data by radio, their reliance on outsiders is reasonable and expected.

Applications that would benefit from this technology are:

- Trucking and delivery
- Mobile sales force
- Sales force
- Trucking
- Emergency service and maintenance

EXHIBIT V-7

TRANSMISSION OF DATA BY RADIO AND CELLULAR TELEPHONE

1. Not using much now. Sees Cellular as one of the highest growth rates in the U.S. When you add data the possibilities are outstanding.

Sees opportunities for outside firms to design, build, and operate networks, and behave as VANs

2. Present radio systems are currently being used mostly for voice communications in the security and other related applications. Not aware of anything else.
3. Not of any interest in our business. May be the trucking or delivery service business, all of our locations are fixed.
4. Not very interesting to people in company's business. Does not have a large trucking fleet or any moving vehicles to communicate to.
5. Has no need for this type of service and does not see any at corporate. However, has not given this any thought, so can't answer questions.
6. There is a potential for a service such as this in company's mobile sales force. Could be important, depending on cost and special features. Use for sales data base to salespeople.

Sees opportunities for firms to design and build networks, to operate networks, to act as VANs if data bases are sales related and oriented to own business.

7. Most of the radio applications are throughout the company and corporate has no service that it provides or is planning at this time. Doesn't own and operate many trucks, relies on couriers.

Sees sales as the application.

Sees opportunities for outside firms to design, develop, and operate networks. Doesn't know about VANs or proprietary information.

8. Nothing in this areas at this time. Doesn't believe that the cellular industry is there yet to make the service attractive to company. Might be a great asset to the sales force.

Can use outside firms to design and develop networks because there is little experience in the field today. Sees opportunities for VANs.

9. Has very large trucking fleet, but no need to communicate with the vehicles. Delivery is between two points nonstop.
10. Has very extensive radio networks as well as cellular telephones. Are currently running tests in putting PC or 3270 compatible in trucks. Could be very critical service. Use for emergency service and maintenance.

Sees opportunities for outside firms to design and build networks, not for VANs or proprietary data bases.

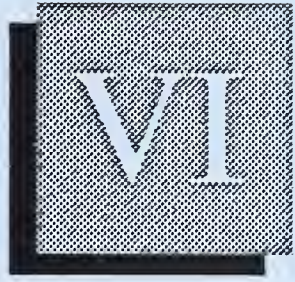

The Vendor Point of View



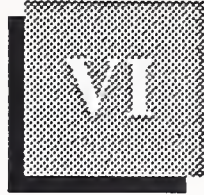

The Vendor Point of View

A

Why Solicit the Vendor's Point of View?

Market managers of companies that provide emerging telecommunications services were interviewed to determine how they viewed opportunities that these emerging communications services provide. More specifically, INPUT wanted to determine how these vendors viewed opportunities for companies that:

- Design and build (install) networks for users
- Manage and operate the users' networks
- Provide communications services as a shared or public network (VAN)
- Provide information to be transported by the network—proprietary electronic data bases

The viewpoint of the vendors with regard to emerging telecommunications services was solicited because:

- They have an understanding of the market for their own products.
- INPUT wished to determine how cooperative they would be with other vendors that wish to use and support their services in the ways specified previously.

INPUT interviewed product managers and national sales managers of the vendors of emerging telecommunications services. The types of companies interviewed are listed below with the same numbers as are used to list the respondents' comments in Exhibits VI-2 through VI-5. Please see the interview guide used in the Appendix. The companies interviewed are as follows:

- 1) Small Aperture Satellites (VSAT)
- 2) Telco
- 3) Data by radio
- 4) Telco
- 5) E-Mail vendor
- 6) Telco
- 7) EDI and E-Mail

B

Emerging Telecommunications Services Vendors' User Views

It is most important to realize that the emerging telecommunications services are provided for the most part by companies that only understand their own offerings. When the product managers are in Telcos or other large communications service companies their attitudes are still parochial. However, these vendors know their own products very well.

- They generally do not know much about other emerging communications services, or the entire spectrum of user needs in any depth.

The restricted knowledge of vendors of emerging telecommunications services is illustrated in Exhibit VI-1, which shows the users' needs and applications as a large circle, and the understanding of vendors of emerging telecommunications services as small areas inside the large circle. It should be noted that:

- The areas of understanding of the vendors of emerging telecommunications services are relatively small. They don't have a full idea of the users' needs and applications.
- The areas are completely separate. They have no understanding of the services provided by other vendors of (different) emerging telecommunications services.

As a result of this lack of knowledge and understanding of total vendor needs:

- Vendors of emerging telecommunications services cannot solve all of a user's problems.
- They can't even integrate their own services into the networks of major users.
- Opportunities exist for other vendors in the industry to solve these problems, and to "fill the gap."

EXHIBIT VI-1

EMERGING TELECOMMUNICATIONS SERVICE VENDORS' RELATIONSHIPS AND KNOWLEDGE OF USER NEEDS

User Needs and Applications

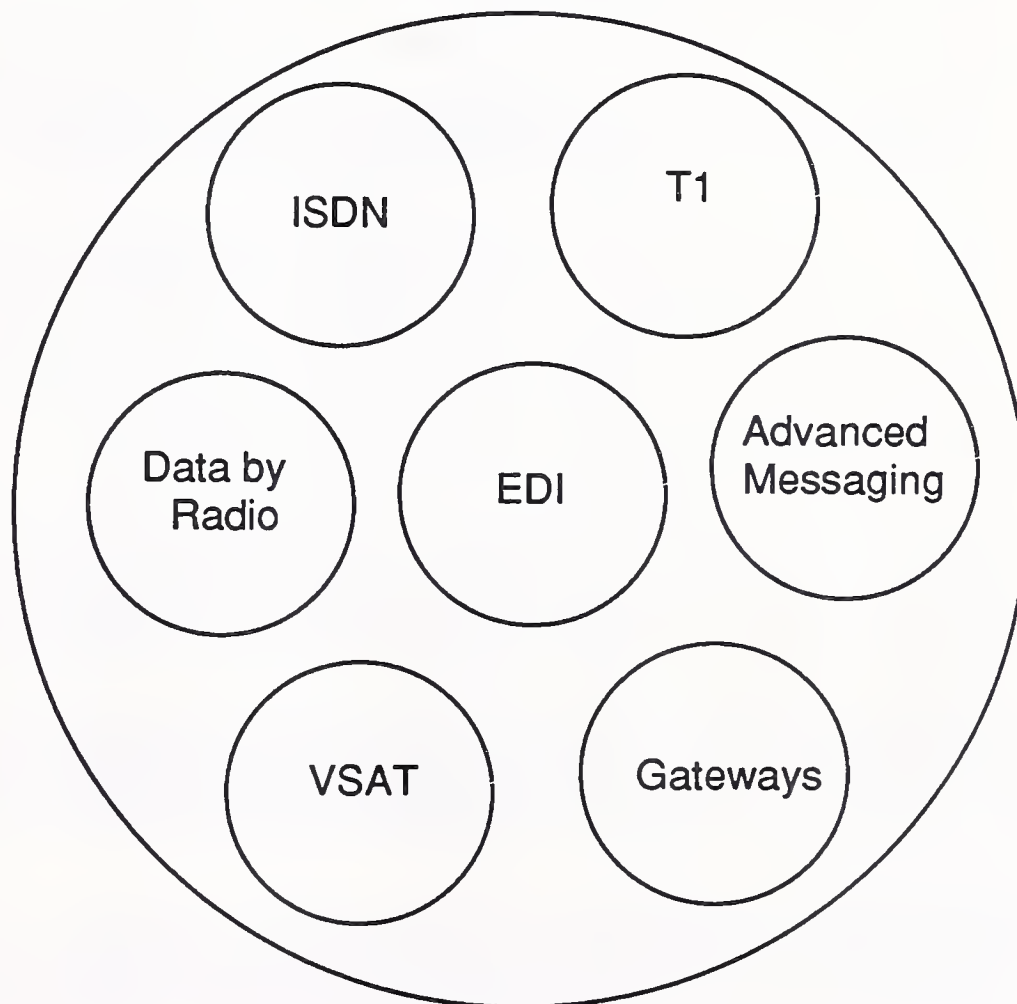

C

Vendor Opportunities

The answers of the seven vendors of emerging communications services to the question of vendor opportunities are shown in exhibit VI-2.

In general vendors of emerging telecommunications services believe there is a need for others to design and integrate these services into the user's network. Notice how uniform the vendors are in their responses to this question.

- They all think additional help is needed.
- They welcome the idea of others building their services into the user networks. This means that they will cooperate with network designers and system integrators.

EXHIBIT VI-2

**VENDORS' VIEWPOINT ON OUTSIDE FIRMS
DESIGNING NETWORKS USING THEIR
(THE VENDORS') SERVICE OFFERINGS**

Do vendors of emerging telecommunications services see opportunities for outside firms to design or build networks for users using the respondents' service?

1. Some Telcom departments are knowledgeable about (service), some are not. Opportunity to help those who are not knowledgeable.
2. No, it's too easy to use.
3. Yes, new technology has new advantages.
4. In discussion with outside companies now.
5. Yes, users in the functional business departments are so busy with their own needs that they need help.
6. Yes, the biggest problem in selling the service is in finding end-to-end applications.
7. Yes, needs for a network are user equipment, user software, and communications. Although respondent will also bid on all parts of the job, network system integrators are very important.

Exhibit VI-3 shows that outside firms should bring applications understanding to the environment to be of value.

EXHIBIT VI-3

ROLE OF OUTSIDE FIRMS IN DESIGNING NETWORKS FOR USERS

What should outside firms bring to the environment, and how should they sell to users?

1. Understand needs. Applications sell.
2. N/A. Service too easy to use.
3. Need knowledge of networks, etc.
4. System integration capabilities, sell by finding out where need is.
5. Bring consulting knowledge and be a solution provider. Sell by approaching functional business units after first getting Telcom Manager's support.
6. Know applications, software, and communications. Know what to do if the application is not working well. Sell to Telcom Manager.
7. Know all three—equipment, software, communications, and also user applications.

- Notice that applications understanding, software, and communications knowledge is viewed as key to the sale.
- In addition, the sale should be to both the communications manager and the end user. The communications manager is sort of a "gate keeper," while the end user has the application that ultimately needs to be solved.

- The description of skills respondents believe are necessary matches the skills of information providers and of network processing companies. The applications sale approach matches the way they do business now.

Adding value to the emerging service and selling the new service with that “added value” to users is a key opportunity for companies that already provide Value-Added Networks (VANs). They can use the unique capabilities of the emerging services to provide unique offerings.

- Data by radio allows VANs to provide superior offerings to companies that have local or nationwide trucking operations. Transfer of data by cellular telephone is ideal for field sales and field service.
- VSATs provide excellent ways to serve construction and extraction industries. Large amounts of data (such as financial) can be delivered at the beginning of the day and updated much more rapidly.
- Companies that provide network services to retail chains can take advantage of VSATs to reach each store in a chain with far more extensive communications services than can be implemented by dial-up communications. In this case leased lines to each store would be too expensive.

The firms that provide emerging communications services generally agree with this (Exhibit VI-4), and those that agree will be cooperative with the VANs that are interested in this opportunity.

EXHIBIT VI-4

**OUTSIDE FIRMS ADDING VALUE
TO THE EMERGING SERVICE
AND RESELLING IT**

What are the opportunities for outside firms to add value to the emerging services and sell them to users?

1. Shared networks for firms below Fortune 500 in size.
2. No service stands alone.
3. Network companies can offer it as part of their offerings. Data networks.
4. Yes, and vendor is making directories and signaling controls available for them.
5. Yes, but as part of a solution to a problem.
6. Don't know. Don't think so.
7. Not really. The opportunity is in software.

All but one of the firms that provide emerging telecommunications services believe that their services will really create new opportunities for proprietary electronic data base providers. Exhibit VI-5 summarizes the firms' responses. These emerging services will allow:

- Larger amounts of information to be distributed.
- Information to remote areas to be distributed by satellites or radio. For example, at a fire site, data on how to handle dangerous chemicals can be delivered to a PC by means of cellular telephone.
- ISDN to provide a wide bandwidth to distribute information to large corporations on their own networks. And when ISDN is connected to small establishments by Centrex they will also be easily reached by data supplied by the ISDN capabilities.

It's worth the time of proprietary electronic data base providers to examine these emerging telecommunications services to see how they can lead to new information base offerings for their existing customers and prospects.

EXHIBIT VI-5

OPPORTUNITIES FOR PROVIDERS OF PROPRIETARY ELECTRONIC DATA BASES

Do respondents see new opportunities for providers of data bases to access users by using the emerging services?

1. A very large opportunity. Now being used to distribute financial data.
2. Yes. Information providers of all types are very interested.
3. No. It's cheaper to do one-way distribution by other techniques.
4. Big opportunity because of the way the service connects to packet switching.
5. Big opportunity there. Opportunity depends upon user needs and value of the service to the user.
6. Yes. Service features allow faster searching through data bases.
7. Very great opportunity. Respondent adds 5 to 10 data bases per week.

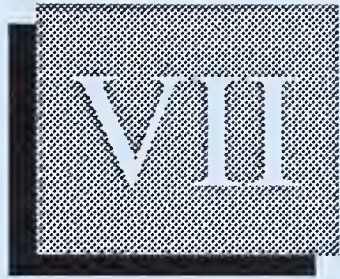

Voicemail: A Unique Service

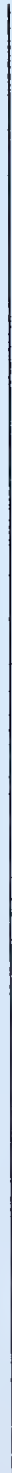

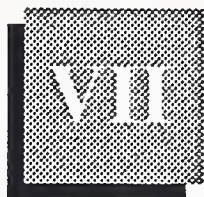

Voicemail: A Unique Service

A

Description of Voicemail

Voicemail is a unique telecommunications service that combines the advantages of telephone use with advanced messaging capabilities.

Exhibit VII-1 shows how voicemail functions. The message medium is voice, which means that the telephone is the input and output terminal.

A message sender uses the touch-tone buttons to provide voicemail instructions for the message he or she wishes to send. The message can be:

- Broadcast to a group of people on a prestored list, for example, to all the field salespeople in the West.
- Transmitted at a specific time, which is useful if many time zones are traversed.
- Re-transmitted until it has been accepted.
- Subject to “password” (via push-button sequence) for it to be received.

Voicemail messages can have attributes of message systems applied to them as follows:

- A message can be held in the recipient’s voicemail box until the recipient is available to hear it. Then (just as in a hard-copy message system), he or she calls the mailbox and checks messages.

EXHIBIT VII-1

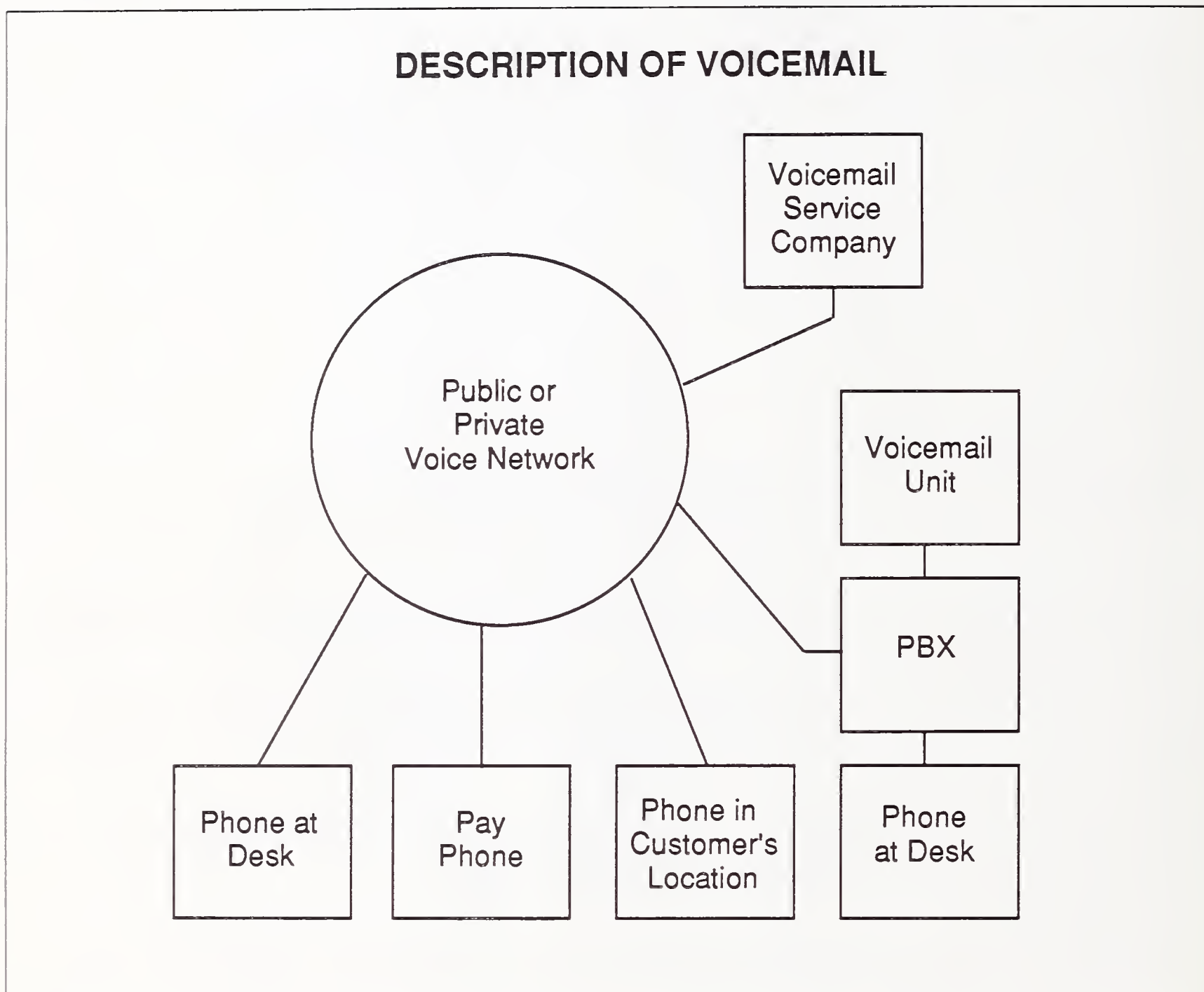

- Messages can be rerouted for others to read.
- The recipient can modify or add comments to the message and return the message to the sender or to others on the mail system.
- A “dated receipt system” allows the message control capabilities of a hard-copy message system to be used with voicemail.

Voicemail is implemented by using any touch-tone telephone as an “input/output” and control device. Since tone is used for control signals, small portable tone devices are required to use rotary telephones.

The company's voice network or the public voice network is used for transmission.

A voicemail unit can be connected to a company's PBX (most PBX vendors offer voicemail units), or it can be a stand-alone device.

- There are also voicemail service bureaus that provide voicemail services together with many other convenience message services, such as telex and fax.

B

Advantages of Voicemail

Voicemail has many advantages, as illustrated in Exhibit VII-2. Basically, it is a true message service that allows all the message functions while it requires no input and output devices and very little user training.

EXHIBIT VII-2

ADVANTAGES OF VOICEMAIL

- Minimum Training—Use touch-tone telephone buttons and simple commands
- No special terminal equipment needed
 - Touch-tone phone
 - Portable tone generator for rotary phone
- A true message service
 - Store and forward
 - Multipoint distribution
 - Time and date stamp processing
 - Limited access
- Cross time zones
- No phone tag
- Can use prerecorded messages
- Particularly good for salespeople, trucking, service people, etc.
- Reduce number of secretaries used to answer phones

Voicemail pays for itself with increased efficiency:

- Reaching people as needed greatly improves their work.
- Secretaries are used for functions other than answering telephones.
- Businesses and people are accessible (by message) seven days a week, twenty-four hours a day.

C

Opportunities Created by Voicemail

The main opportunities that voicemail creates are:

- For value-added network service vendors, there is another feature they can add to the network. Voice synthesizers allow data to be delivered via voice (short messages only). Voicemail can also be used for message notification (call out to tell a recipient there is an E-Mail message in his mailbox, etc.).
- Suppliers of proprietary electronic data bases have a new way to distribute data.
 - By voicemail directly if only a small amount of information is to be distributed. There is hardware that can take ASCII and convert it to synthesized voice.
 - Using voicemail as a notification that something has changed, or some critical information has become available, for information that is not suitable for transmission by voicemail (too much information)

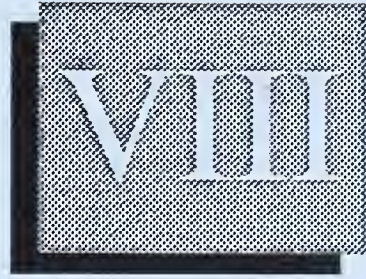

Conclusions and Recommendations

Vertical line on the left side of the page.



Conclusions and Recommendations

This chapter presents INPUT's recommendations to clients of the Market Analysis and Planning Service, as to how they should take advantage of the opportunities caused by the emerging telecommunications services discussed in this report.

A

Recommendations to Processing Service Vendors

All of these new services have added even more complexity to the design and use of telecommunications networks. This new complexity, coupled with the increased responsibilities caused by the break up of AT&T, has resulted in even more work for the telecommunications department.

The new services mostly involve data and its processing. Processing service vendors have advantages in this situation:

- They understand data and its processing despite the complexity.
- They have existing relationships with accounts (the foot is in the door).
- They are nationwide.

Exhibit VIII-1 summarizes how INPUT thinks processing service vendors can take advantage of these new services.

First, expertise must be developed. All of these services are new, and they are not just extensions of previous services.

It is likely that processing service vendors will wish to use some of these emerging services in their own operations, which has the advantages of:

- Learning by doing
- Having a showcase for prospects

EXHIBIT VIII-1

RECOMMENDATIONS TO PROCESSING SERVICE VENDORS

- Learn about the new emerging telecommunications services:
 - Develop sufficient expertise to assist accounts in design and installation of these services.
 - Develop sufficient expertise to connect from these services to your own networks and processing services.
- Develop a strategy for which services you wish to offer accounts.
 - Design only (for their networks)
 - Installation (of the new services)
 - Processing information that is received via these services
 - Your network
 - The account's network
 - Distributing information processed for your accounts to them via these services (nationwide distribution)
- Decide where these services can be of value in key accounts.
 - Telecommunications department
 - MIS department
 - Specific users
- Decide if the information transmitted by these services creates new processing opportunities.
 - Develop processing ability in these new areas.
- Seek new business opportunities.
 - Existing accounts
 - New accounts
- Develop relationships with companies that will supply the emerging communications services.
 - Offer to supply processing that will allow accounts to take advantage of these emerging services.
 - Introduce the vendors to locations in your accounts that can use these services.
 - Seek leads from the vendors of emerging services.
 - Because of the expertise and processing ability you have developed.
 - Because of the leads that you have given them.
 - Try to work at the regional level, as well as at the corporate level.

Next there have to be some strategy decisions as to what the processing service vendor wishes to gain from the new developments.

- It can use the emerging services as new gateways into its processing. For example, VSATs can collect information nationwide, which then can be processed and returned by landlines or VSAT.
- It can expand the services it offers from processing to include network design and installation.
 - Design and installation services can make money by themselves.
 - Design and development is also a natural tie in to processing the information.

The additional services (design, development, processing information) will result in sales opportunities in new areas with existing accounts. The processing service vendors should decide as part of their strategy which of these new areas they wish to sell to:

- Telecommunications departments are new contacts. The information that is transported by the telecommunications department must eventually be processed, and thus the telecommunications department can lead to new users.
- The MIS department may need help in geographical areas away from headquarters.
- Users with unique requirements provide vertical markets. Perhaps the departments involved in trucking need help in installing and processing data by radio, or perhaps the field service department can use assistance.

Examination of these services will provide opportunities where a processing service vendor can provide unique services. If so new markets open at:

- Existing accounts for new individual customers
- New accounts

The vendors of the emerging telecommunications services don't really understand all of the processing needs of users. Even if the supplier of an emerging service is a large Telco, the product line managers don't have this broad understanding.

- Thus, the vendors of emerging services need and want allies to help customers use their services. Processing services vendors should cultivate these sources of leads.

- Processing service vendors can supply the processing necessary to make a service viable for a user.
- They can also help their (the processing service vendors') own accounts by introducing them to the emerging service technology, and its advantages for them.

B

Recommendations to Network Service Vendors

Network service vendors have new technologies to add to their networks, and this new technology will create new opportunities. (Exhibit VIII-2)

The network service vendors should connect to these new services to allow users to easily integrate them into the users' operations.

- A company might want to use data by radio in local areas but then connect it to a central site for processing. Perhaps ISDN has some advantages for telemarketing departments but the information required is located at a central data base.
- Translation services for incompatible services will allow users to install the new communications services wherever they choose.
- Many users can design and install services near headquarters but not in remote field locations. Here is an opportunity to provide assistance and get a "foot in the door."

Providing assistance to customers that wish to use new services but don't know how will provide revenue and develop new contacts. Because of the complexity of the emerging telecommunications services, there is a need for help.

- Users stated they need help in using EDI, satellites, and ISDN. Anything out of the ordinary requires a level of expertise the telecommunications staffs typically don't have.
- It's also an opportunity to offer a turnkey solution to a portion of the user needs, which will provide an ongoing revenue source.

The vendors of emerging telecommunications services require help to install and manage operation of the services at users' sites. They are in a position to supply leads.

- Regional salespeople of emerging telecommunications services who need help in sales will just as soon go to a network service vendor as to their own corporation if they feel that their own corporation cannot supply local assistance in time to close the sale.

EXHIBIT VIII-2

RECOMMENDATIONS TO NETWORK SERVICE VENDORS

- Develop gateways to the emerging communications services.
 - Be able to provide nationwide communications for companies that use these services in local (separated) regions.
 - Wherever possible supply translation services for incompatible services.
 - Supply communications services in regions where user companies need help.
- Provide assistance to customers that wish to use these emerging communications services but don't know how.
 - Know the technology details.
 - Know the user applications details.
 - Be able to get users "off the ground" in the use of services they (the users) have little experience in.
 - Provide "turnkey" networks.
- Build relationships with the vendors of emerging communications services.
 - Show them your expertise.
 - Tell them that you will provide these services to users.
 - Tell them you will connect to the emerging communications services.
 - Trade leads.
 - Try to work at the regional level as well as at corporate.

C

Recommendations to
Proprietary Electronic
Information Service
Vendors

New telecommunications services provide new opportunities to disseminate information, and to disseminate information in a different form (See Exhibit VIII-3).

EXHIBIT VIII-3

RECOMMENDATIONS TO PROPRIETARY ELECTRONIC INFORMATION SERVICE VENDORS

- Understand the unique capabilities of emerging communications services.
 - Perhaps they allow you to reach customers that could not easily be reached before.
 - Better economics
 - Provide data more often (greater effective bandwidth)
 - Better reliability (no local loops)
 - Users connected to a new service for some other reason, which now are potential customers.
 - Perhaps they allow more economic or timely ways to develop proprietary data bases.
- Build gateways to new services.
 - Reach customers any way possible.
 - Allow customers to reach you.
- Determine if you can create new products (proprietary data bases) because of the existence of the new emerging services.
- Build relationships.
 - Processing service vendors to obtain unique data
 - Vendors of emerging services to let them tell their prospects to buy the service because it supplies access to your data
 - Network service vendors to help distribute your data

- VSATs make it practical to rapidly deliver large amounts of data nationally.
- ISDN is a way to provide information that people can discuss with each other. The control channel can be used to search a data base. The wider bandwidths allow graphics and better-looking screens that are easier to use and convey more information.
- New services such as EDI also develop information that can be collected and sold as proprietary.

To take advantage of these new services, the information service vendor must:

- Connect to them, which requires gateways.
- In turn these gateways will increase the number of people that can access the information.

The other half of proprietary information bases is collecting the information. Here the new services will produce information.

- The information service vendors should start to build relationships with users of the new services and vendors of the new services. Determine what new information is going to be available, and how to obtain this information.

It's important to build relationships with vendors of the emerging telecommunications services and with network processing vendors, because each new installation is a new prospective customer of proprietary electronic data base services.

- Tell the vendors of emerging communications services and the network processing services vendors what unique information is available and who should use it. It will help them sell both their services and the proprietary information.

D

Recommendations to Professional Service Vendors

All of these new services will cause an increase in the complexity of designing, installing, and operating telecommunications networks. Thus there are opportunities for professional services vendors (See Exhibit VIII-4) to:

- Assist customers by providing them with consulting and/or training.
- Provide systems operation and turnkey systems. This is particularly valuable in unique situations where the user company has little experience and does not want to develop such experience. For example:

EXHIBIT VIII-4

**RECOMMENDATIONS TO PROFESSIONAL
SERVICE VENDORS**

- Develop expertise in these emerging communications services.
 - Be able to assist customers in their use.
 - Consulting
 - Education and training
- Offer systems operation in unique situations.
 - The service cannot be easily used by customers.
 - You can do a better job of operating the network with emerging communications services than the user company.
- Build relationships with vendors of emerging communications services.
 - Be able to provide installation, design, and operation where needed.
 - Receive leads where assistance is required.
 - Keep ahead of your customers in knowledge about the service.

- Use of VSAT to reach construction sites or other separate and inaccessible facilities
- Use of ISDN for telemarketing where data management and ISDN usage are combined

Building relationships with vendors of emerging telecommunications services is key:

- They want their services sold but can't sell them if users don't know how to install or use them.
- Professional service vendors want leads and to be recommended by the network service vendors.

E

Concluding Remarks

Never before have there been so many new and different telecommunications services emerging into the marketplace. They represent:

- Different technologies
- New processing applications
- The results of liberalized regulatory decisions

The telecommunications marketplace is changing as fast as the computer and computer applications marketplace, and it has become even more complex.

These emerging telecommunications services are not interesting technical curiosities looking for a home, and they are not "boutique" services looking for an obscure niche.

- They are services offered by the largest telecommunications companies in the U.S. and are being used or seriously considered by the largest U.S. corporations (Fortune 500/50).

As a result of these changes, which are both fast and significant in size, opportunities abound.

INPUT strongly recommends to its clients that they consider these opportunities seriously. They should:

- Understand the telecommunications services and their impact.
- Devise strategies to take advantage of these opportunities.
- Talk to their key accounts.
- Build relationships with the vendors of the emerging telecommunications services.

Get Started!

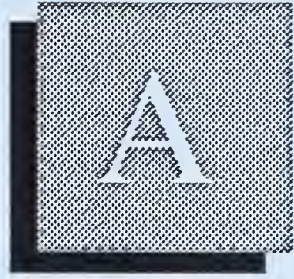

Appendix: User Questionnaire

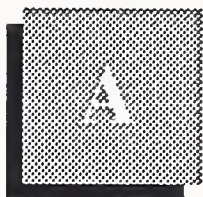

Appendix: User Questionnaire

Hello, my name is _____. I'm with INPUT in the New York area. We're a management planning firm and we're working on a report regarding new developments in the network communications and processing area. I'd appreciate your perspectives and I think that you'll find the discussion interesting. In return for your cooperation, I'd be happy to send you a copy of the executive overview of the report for your personal use. The interview should take about 15 - 20 minutes. Is now a good time?

First I will list the new developments which we wish to ask for your perspectives about. Then we will discuss them one by one. The developments we are interested in are:

- Satellites which require a small aperture antenna.
- ISDN (Integrated Services Digital Network).
- Advanced message services.
- Gateways from local telephones to E-Mail, and data bases.
- T1 transmission services.
- EDI (Electronic Document Interchange).
- Transmission of data by radio and cellular telephone.

Now lets talk about each service.

1. Satellites which require an antenna with a small aperture are easy to install and can easily bring satellite data communications to any location in the U.S.

How valuable is this service to large corporations such as yours?

What applications do you see for it?

Can you guess as to the amount of usage? (hours per day; dollar amount per month; other measure)

Do you see opportunities for outside firms to design or build networks for users using this service? Please discuss.

Do you see opportunities for outside firms to operate networks of this type for users? Please discuss.

Do you see opportunities for firms other than the satellite transmission firms to provide value added network services to users using this technology? These services will process the information as well as store and distribute it. Please discuss.

Do you see opportunities for firms to provide proprietary information (access to data bases) to users using this technology? Please discuss.

2. ISDN (Integrated Services Digital Network) allows simultaneous transmission of voice and data. It also provides a great deal of flexibility to users as to how they use the larger bandwidth made available to them.

How valuable is this service to large corporations such as yours?

What applications do you see for it?

Can you guess as to the amount of usage? (hours per day; dollar amount per month; other measure)

Do you see opportunities for outside firms to design or build networks for users using this service? Please discuss.

Do you see opportunities for outside firms to operate networks of this type for users? Please discuss.

Do you see opportunities for firms other than the telcos to provide value added network services to users using this technology? These services will process the information as well as store and distribute it. Please discuss.

Do you see opportunities for firms to provide proprietary information (access to data bases) to users using this technology? Please discuss.

3. Advanced message services convert formats, convert from data to facsimile output, provide multiple distribution of messages, provide bulletin boards, facilitate communicating with individuals inter company with incompatible equipment or software and all connect to PCs.

How valuable is this service to large corporations such as yours?

What applications do you see for it?

Can you guess as to the amount of usage? (hours per day; dollar amount per month; other measure)

Do you see opportunities for outside firms to design or build networks for users using this service? Please discuss.

Do you see opportunities for outside firms to operate networks of this type for users? Please discuss.

Do you see opportunities for firms other than the existing message service carriers to provide value added network services to users using this technology? These services will process the information as well as store and distribute it. Please discuss.

Do you see opportunities for firms to provide proprietary information (access to data bases) to users using this technology? Please discuss.

4. Gateways by local Bell companies from local telephones to E-Mail and data bases will allow anyone with a PC at any location in your company to have access to E-Mail, public data bases, and bulletin boards. Although these services have been in existence before, some think that the entry of the local Bell companies into the field will greatly increase usage.

How valuable is this service to large corporations such as yours?

What applications do you see for it?

Can you guess as to the amount of usage? (hours per day; dollar amount per month; other measure)

Do you see opportunities for outside firms to design or build networks for users using this service? Please discuss.

Do you see opportunities for outside firms to operate networks of this type for users? Please discuss.

Do you see opportunities for firms other than the local Bell companies to provide value-added network services to users using this technology? These services will process the information as well as store and distribute it. Please discuss.

Do you see opportunities for firms to provide proprietary information (access to data bases) to users using this technology? Please discuss.

5. T1 Transmission services allow a corporation to increase the efficiency of its network by combining signals into one high bandwidth channel. They also facilitate wideband communications.

How valuable is this service to large corporations such as yours?

What applications do you see for it?

Can you guess as to the amount of usage? (hours per day; dollar amount per month; other measure)

Do you see opportunities for outside firms to design or build networks for users using this service? Please discuss.

Do you see opportunities for outside firms to operate networks of this type for users? Please discuss.

Do you see opportunities for firms other than the T1 transmission firms to provide value added network services to users using this technology? These services will process the information as well as store and distribute it. Please discuss.

Do you see opportunities for firms to provide proprietary information (access to data bases) to users using this technology? Please discuss.

6. EDI (Electronic Data Interchange) allows transmission of business documents with formats and forms rather than just messages. It greatly facilitates business transactions by electronic communications.

How valuable is this service to large corporations such as yours?

What applications do you see for it?

Can you guess as to the amount of usage? (hours per day; dollar amount per month; other measure)

Do you see opportunities for outside firms to design or build networks for users using this service? Please discuss.

Do you see opportunities for outside firms to operate networks of this type for users? Please discuss.

Do you see opportunities for new firms to provide value added network services to users using this technology? These services will process the information as well as store and distribute it. Please discuss.

Do you see opportunities for firms to provide proprietary information (access to data bases) to users using this technology? Please discuss.

7. Transmission of data by radio and cellular telephone allows data to reach remote and moving locations. For example, a truck can receive or dispatch information into its computer by radio while it is moving. Anyone with a cellular telephone can connect to a portable PC to exchange data, etc.

How valuable is this service to large corporations such as yours?

What applications do you see for it?

Can you guess as to the amount of usage? (hours per day; dollar amount per month; other measure)

Do you see opportunities for outside firms to design or build networks for users using this service? Please discuss.

Do you see opportunities for outside firms to operate networks of this type for users? Please discuss.

Do you see opportunities for firms other than the cellular carriers to provide value added network services to users using this technology? These services will process the information as well as store and distribute it. Please discuss.

Do you see opportunities for firms to provide proprietary information (access to data bases) to users using this technology? Please discuss.

8. Are there any other communications developments which you feel are significant? Please discuss.



Appendix: Vendor Interview Guide



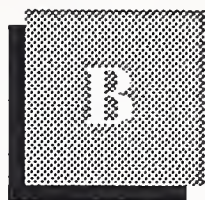

Appendix: Vendor Interview Guide

Hello, My name is _____. I'm with INPUT in the New York area. We're a management planning firm with clients in the user MIS area and as vendors in the computer and communications area.

INPUT is preparing a report on opportunities which are emerging because of new developments in the network communications and processing area. We are very interested in your perspectives on these developments.

In exchange for your cooperation we'll send you the executive overview of the report for your personal use.

The interview should take about 15 - 20 minutes. Is now a good time?

First let me list the new developments which we are studying. We will mostly want to ask you about developments in your own area.

- Satellites which require a small aperture antenna (VSAT).
- ISDN (Integrated Services Digital Network).
- Advanced message services.
- Gateways from local telephones to E-Mail, and data bases.
- T1 transmission services.
- EDI (Electronic Data Interchange).
- Transmission of data by radio and cellular telephone.

Now lets talk about _____
which is a service that your company offers.

In which type of companies is this service used?

What are some of the key applications?

What sort of usage do you expect in a typical Fortune 500 company? (hours per day; dollar amount per month; other measure)

Which areas of the company will buy and use it?

What is the market size and growth for this service?

Do you see opportunities for outside firms to design or build networks for users using this service?
Please discuss:

What type of network?

What should outside firms bring to the environment to be successful?

How should they be sold?

Which users are the best target?

Do you see opportunities for outside firms to operate networks of this type for users? Please discuss.

What type of network?

What should outside firms bring to the environment to be successful?

How should they be sold?

Which users are the best target?

Do you see opportunities for outside firms to increase the value added to this service and to sell/resell it to users? Please discuss.

What type of value added?

What should outside firms bring to the environment to be successful?

How should they be sold?

Which users are the best target?

Do you see opportunities for firms to provide proprietary information (access to data bases) to users by using these services? Please discuss.

What type of information?

What should outside firms bring to the environment to be successful?

How should it be sold?

Which users are the best target?

With regard to the other services (below), where do you think the opportunities are for firms in the network services processing area? And how do you think they should take advantage of these opportunities?

Satellites which require a small aperture antenna (VSAT).

ISDN (Integrated Services Digital Network).

Advanced message services.

Gateways from local telephones to E-Mail, and data bases.

T1 transmission services.

EDI (Electronic Data Interchange).

Transmission of data by radio and cellular telephone.

What advice do you have for firms in the network services and processing area with regard to new opportunities which have arisen because of the new developments we have discussed?

