

September 21, 1990

Dear Client;

Enclosed is the report, *The EDI Market, 1990-1995: Forecasts, Implementations, Trends*, of INPUT's Electronic Data Interchange Program (EDIP).

The report is the most comprehensive overview of the EDI market available today. In it you will find detailed forecasts of the markets for EDI software, network services and professional services. The report discusses major developments and trends in EDI today and examines EDI use throughout the U.S. economy with extensive analysis of applications in all areas. INPUT has developed an effective new tool for graphically "mapping out" where and how EDI is being used in the economy today. The EDI Input-Output Matrix, as we call it, is included in the report as a fold out.

We have forecast the EDI market for software and services to be approximately \$117 million for 1990. Growing at an estimated compound annual growth of 19%, we expect it to reach \$276 million by 1995. We conclude that the markets for network and professional services are "younger" than the market for software. Growth rates in the market for software, while certainly remaining positive throughout the next five years, will fall. Demand for services, however, will rise at increasing rates.

We are pleased to provide you with what we think as an exceptional report on one of the most exciting markets in information services today. As always, we are most interested in your responses to our work and would be most pleased to receive from you the enclosed evaluation.

Sincerely,

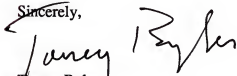

Torrey Byles
EDI Program Manager

Enclosure

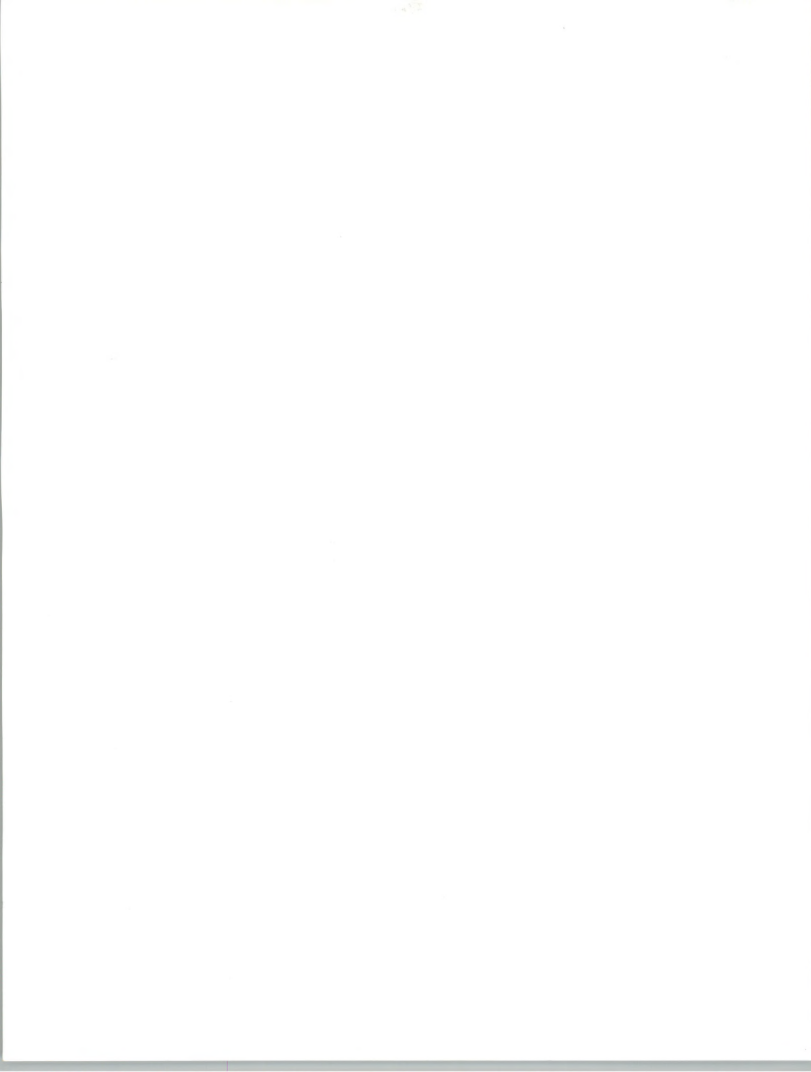

FOLD HERE



NO POSTAGE
NECESSARY
IF MAILED
IN THE
UNITED STATES

BUSINESS REPLY MAIL

First Class Permit No. 982 Mountain View, CA

POSTAGE WILL BE PAID BY ADDRESSEE

*Attention: Marketing Department***INPUT**

1280 Villa Street

Mountain View, CA 94041-9912



FOLD HERE



Report Quality Evaluation

To our clients:

To ensure that the highest standards of report quality are maintained, INPUT would appreciate your assessment of this report. Please take a moment to provide your evaluation of the usefulness and quality of this study. When complete, simply fold, staple, and drop in the mail. Postage has been pre-paid by INPUT if mailed in the U.S.

Thank You.

1. Report title: ***The Electronic Data Interchange Market, 1990-1995 Forecast, Implementations, Trends*** (EDI90)

2. Please indicate your reason for reading this report:

- Required reading New product development Future purchase decision
 Area of high interest Business/market planning Systems planning
 Area of general interest Product planning Other _____

3. Please indicate extent report used and overall usefulness:

	Extent		Usefulness (1=Low, 5=High)				
	Read	Skipped	1	2	3	4	5
Executive Overview	<input type="checkbox"/>	<input type="checkbox"/>	<input type="checkbox"/>	<input type="checkbox"/>	<input type="checkbox"/>	<input type="checkbox"/>	<input type="checkbox"/>
Complete report	<input type="checkbox"/>	<input type="checkbox"/>	<input type="checkbox"/>	<input type="checkbox"/>	<input type="checkbox"/>	<input type="checkbox"/>	<input type="checkbox"/>
Part of report (____ %)	<input type="checkbox"/>	<input type="checkbox"/>	<input type="checkbox"/>	<input type="checkbox"/>	<input type="checkbox"/>	<input type="checkbox"/>	<input type="checkbox"/>

4. How useful were:

- Data presented
- Analyses
- Recommendations

5. How useful was the report in these areas:

- Alert you to new opportunities or approaches
- Cover new areas not covered elsewhere
- Confirm existing ideas
- Meet expectations
- Other

6. Which topics in the report were the most useful? Why? _____

7. In what ways could the report have been improved? _____

8. Other comments or suggestions: _____

Name _____ Title _____

Department _____

Company _____

Address _____

City _____ State _____ ZIP _____

Telephone _____ Date completed _____

Thank you for your time and cooperation.

M&S 633/01 12/89

INPUT

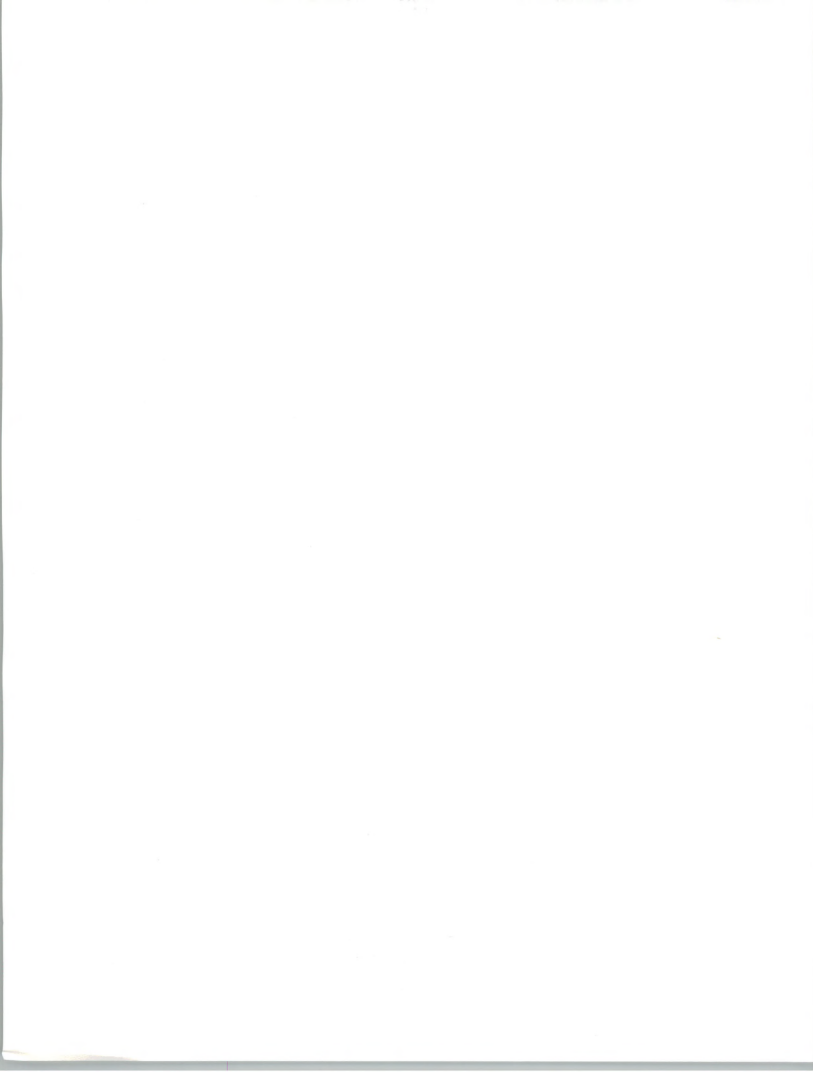

SEPTEMBER 1990

THE ELECTRONIC DATA INTERCHANGE MARKET

1990-1995

FORECAST,
IMPLEMENTATIONS,
TRENDS



Published by
INPUT
1280 Villa Street
Mountain View, CA 94041-1194
U.S.A.

Electronic Data Interchange Program

***The Electronic Data Interchange
Market, 1990-1995
Forecast, Implementatlons, Trends***

Copyright ©1990 by INPUT. All rights reserved.
Printed in the United States of America.
No part of this publication may be reproduced or
distributed in any form or by any means, or stored
in a data base or retrieval system, without the prior
written permission of the publisher.

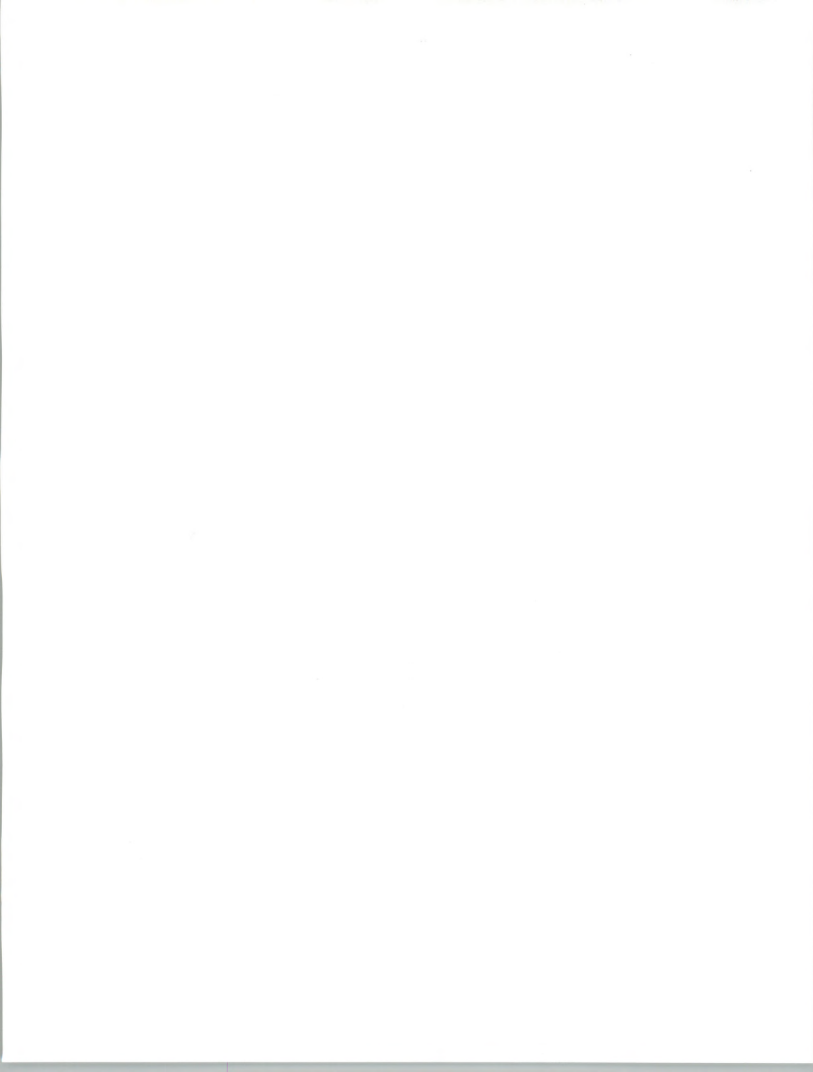

Abstract

Electronic Data Interchange (EDI) is being adopted by companies and government agencies as a means of facilitating commercial transactions in virtually every sector of the economy. Applications of EDI in, for example, advertising, education, and government demonstrate EDI's viability for any kind of exchange, not just exchanges found in the mainstream EDI areas of manufacturing, distribution, and transportation.

This study, one of a series on EDI, examines the wide range of applications of EDI. It assesses the overall use of EDI in the economy, how it is being applied in 35 industrial/commercial sectors, the concerns and practices of EDI users today, how much users are spending on EDI products and services, how much the market for these products and services will grow through 1995, who the leading vendors of these products and services are, and the features and characteristics of these products and services.

The report is intended to be an aid to both EDI users and vendors. Users will find it useful in helping them understand the issues of EDI, identifying EDI applications and trading partners in their particular value chain, and familiarizing themselves with the vendors of the market. Vendors will find the report useful for its competitive and market size intelligence, its overview of the many applications and industry niches of EDI, and its exposé of what users require in new products and services.

The report presents a new tool for analyzing EDI: the EDI Input-Output Matrix. The matrix illustrates how EDI connects organizations and industries in a web of intersecting, interrelated value chains. Both users and vendors benefit from such an economywide mapping of EDI applications.



The macroeconomic view of this report, examining as it does whole value chains of the entire economy, is complemented by a microeconomic view of EDI in INPUT's study, *EDI: Business Integration Issues*.

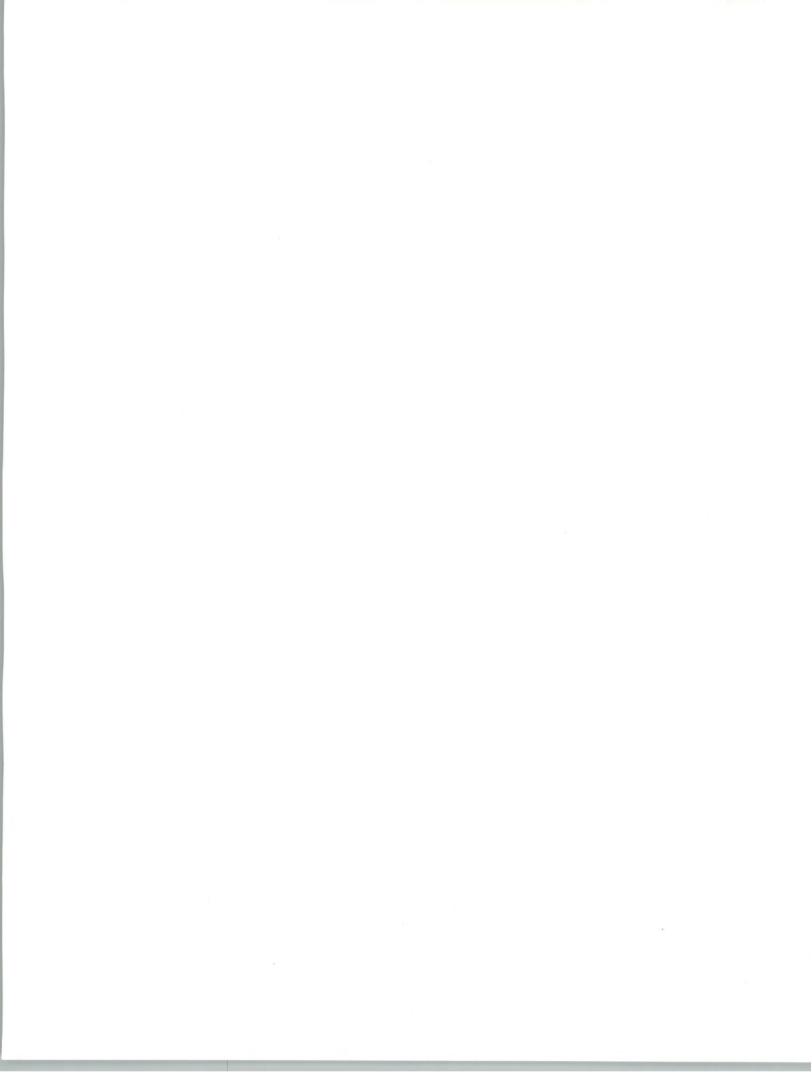

Table of Contents

I	Introduction	1
	A. Scope of the Report	1
	B. Data Collection	2
	1. Interviews	2
	a. EDI Users	2
	b. Associations	3
	c. Vendors	5
	2. Product, Service and Industry Analysis	5
	3. Related Program and Custom Research	5
	C. Report Structure	5
	D. Related INPUT Reports	6
<hr/>		
II	Executive Overview	7
	A. Market Directions	7
	B. Market Opportunities	8
	C. User Issues	12
	D. Conclusions	13
<hr/>		
III	Background on EDI	15
	A. Introduction	15
	B. The Role of Standards	16
	C. Benefits of Using EDI	16
	D. EDI and Other Data Communication Applications	18
	E. The Role of Value-Added Networks	18
	F. The Role of Software	20
	G. User Trends in Adopting EDI	21
	1. Reasons for Implementing	21
	2. The "Hub and Spoke" Phenomenon	21
	3. Customer Premise Data Format Translation	21
	4. User Platforms	21



Table of Contents (Continued)

III	5. Use of Networks	22
	6. Relationships with Trading Partners	22
	7. EDI Use Grows in Two Dimensions	22
	8. Parallel Paper and Electronic Systems	22

IV	EDI Input-Output Analysis	25
	A. Definition	25
	B. Relevance to EDI	26
	C. How to Read the EDI Input-Output Matrix	29
	D. Uses of the Input-Output Matrix	30
	1. General	30
	2. Users	30
	3. Vendors	31
	a. General	31
	b. Network Service Providers	31
	c. Software and Professional Services	31
4. Varieties of Data in Cells	32	
E. Implications of Input-Output Analysis	32	

V	Market Size and Forecast	33
	A. Introduction	33
	B. Challenges of Measuring the EDI Market	33
	1. Counting the EDI Marketplace	33
	2. EDI Users versus EDI Trading Relationships	34
	C. Assumptions of the Forecast Model	37
	1. Network Services	38
	2. Software	39
	3. Professional Services	39
	D. Data Presentation	40
	1. Leading Vendors	40
	2. Market Size and Forecasts	42
	E. Discussion of Forecast	44
F. Reconciliation with Earlier INPUT Forecasts	47	



Table of Contents (Continued)

VI	EDI Market Trends	49
	A. Introduction	49
	B. Software Products	52
	1. Continued Migration of Value-Added Network Services to Customer-Site Software	52
	2. Communication Gateway/EDI Server Architectures	54
	3. Emergence of a Three-Tiered Market for Message-Switching Software	55
	4. Event-Driven and Real-Time EDI Architectures	56
	5. EDI Interfaces Built into Application Programs	58
	6. Inexpensive EDI Software for Turnkey Implementations	59
	7. New Sources of Software	60
	8. Market Consolidation through Mergers and Acquisitions	62
	9. EDI/EFT Software	62
	10. Softness in EDI Software for Midrange Systems	62
	11. Programming Tools in Translation Software	63
	C. Network Service Trends	64
	1. Summary of Trends	64
	a. Market Consolidation through Mergers and Acquisitions	64
	b. International Expansion	65
	c. Internetworking	66
	d. Financial EDI Services	67
	e. Real-Time Communication Sessions	68
	f. Data Transmission a Commodity, Low-Profit Business	68
	g. New Value-Added Services Introduced	68
	h. Service Providers Offering Software	70
	i. Service Providers Offering Systems Integration Services	71
	j. Service Providers Offering Educational and Consulting Services	71
	k. Switch Software Being Sold or Licensed	71
	2. Similarities in Successful Service Provider Offerings	71
	D. Professional Service Trends	72
	1. Background	72
	2. Market Segments	72
	a. EDI Software Development	72
	b. Consulting	73
	c. Education and Training	74
	d. Systems Operations	74
	3. Trends in EDI Professional Services	75

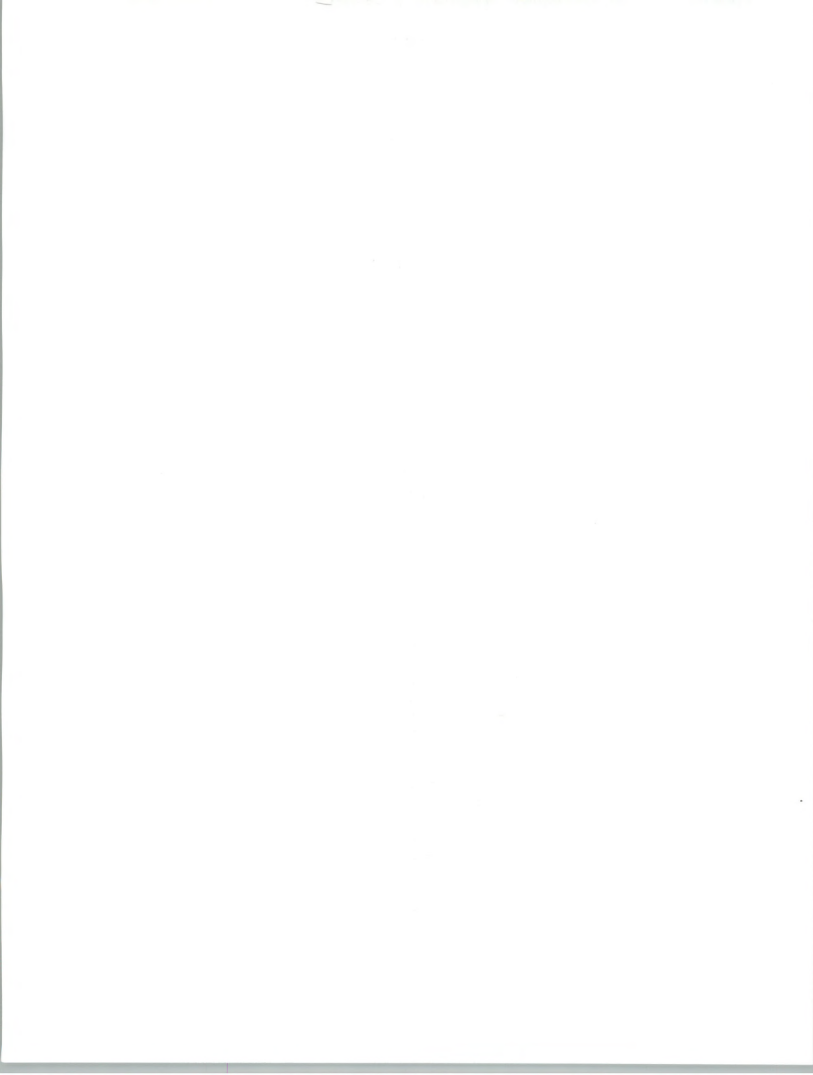

Table of Contents (Continued)

VII

EDI Trading Communities and Applications	77
A. Automobile Manufacturing	77
1. Autos and Trucks	77
a. Trading Partner Growth	78
b. Transaction Set Growth	79
c. Other Advanced Services	80
2. Auto Parts	81
B. Paper, Printing, and Publishing Industries	83
1. Magazine and Newspaper Publishing	84
a. Real-Time Needs	85
2. Book Publishing	85
C. Retail, Apparel, and Textile Industries	86
1. Advanced Services	89
a. Inventory Modeling	90
b. Electronic Payments	91
c. Real Time	91
D. Hardlines	92
E. Electrical	93
F. Electronics	94
G. Oil	96
1. Real-Time EDI	97
2. Data Bases	98
3. Electronic Funds Transfer	98
H. Grocery Industry	98
1. Electronic Payments	102
2. Data Bases	102
3. Real-Time Systems	103
I. Chemicals	104
J. Transportation	107
1. Trucking	108
a. EDI Applications and Advanced Services	109
2. Railroads	110
3. Airlines	114
4. International Trade Transportation	114
a. Deep Sea Shipping	117
b. Air Cargo and Couriers	118
c. Port Authorities	119
d. U.S. Customs	121
e. Transport Services—Customs Brokers and Freight Forwarders	121

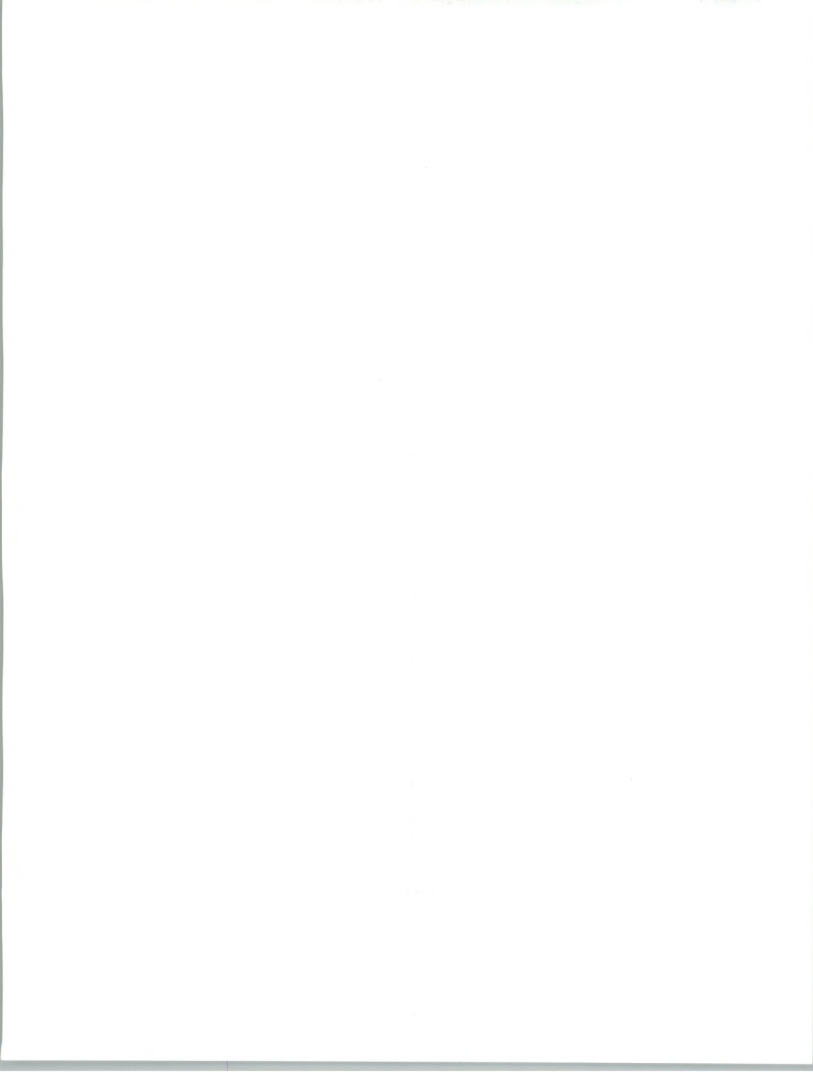

Table of Contents (Continued)

VII		
	K. Utilities	123
	1. Utility EDI Purchasing	123
	2. Utility EDI Billing	124
	3. Electronic Payments	125
	L. Communications Industry	125
	1. Film Distribution	126
	2. Commercial Data Base Vendors	128
	3. Graphics Data Bases	128
	4. Library of Congress and University Libraries	128
	5. Advertising	130
	M. Finance	130
	1. Banking	130
	a. Banks as Service Providers	131
	b. Financial EDI Market Size	131
	c. Financial EDI: Data Formats and Network Issues	134
	2. Factoring Services	136
	3. Equipment Leasing	137
	4. Mortgage Banking	138
	5. Insurance	141
	a. Property and Casualty Insurance	141
	b. Health Insurance	143
	c. Advanced Services	143
	N. Government	143
	O. Agriculture	149
	P. Construction	149
	1. Need for Advanced EDI Services	151
	Q. Education	152
	1. Data Base Needs	155
	a. Course Description Catalogs	155
	b. A National Student Data Base	156
	2. Case Study: University of Texas, Austin	156
	R. Health Care	157
	1. Health Insurance	157
	a. Electronic Funds Transfers	160
	b. Processing Services	161
	c. Real-Time Systems	161
	d. Data Bases	161
	e. Case Study	161
	2. Pharmaceutical Supplies	162
	a. Data Base Services	163
	b. Real-Time Systems	163
	c. Electronic Payments	163
	3. Medical and Surgical Supplies	163

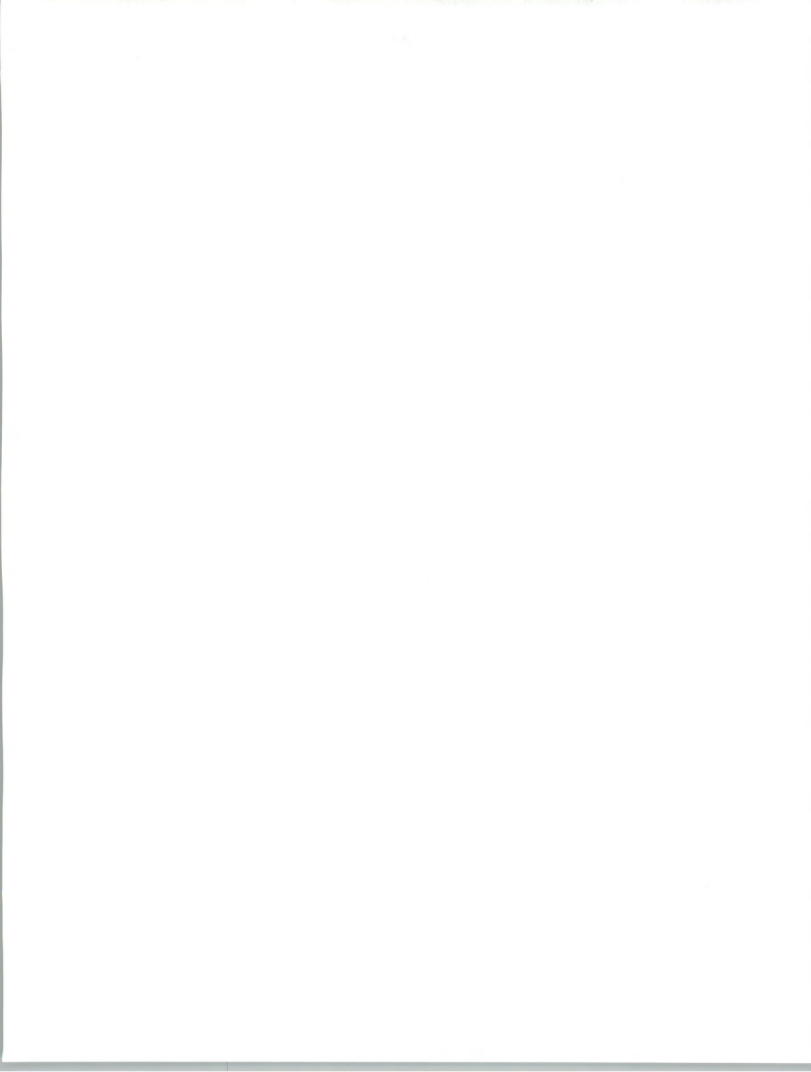

Table of Contents (Continued)

VII	S. Service Industries	165
	1. Temporary Help Agencies	167
	2. Subscription Agencies	168
	3. Video Rental Stores	169
	4. Florists	169
	5. Travel and Tourism	169
	6. EDI Transaction Sets that Characterize People	169

VIII	Conclusions and Recommendations	171
	A. Conclusions	171
	B. Recommendations for Specific EDI Constituencies	172
	1. Users	172
	2. Network Providers	172
	3. Software Vendors	173
	4. Professional Services Providers	174
	C. Future Directions of EDI	175

Appendixes	A. Definitions	179
	B. EDI Market Forecast By Delivery Mode, 1990-1995	181
	C. Forecast Reconciliation	183
	D. EDI User Questionnaire	185



Exhibits

I	<ul style="list-style-type: none"> -1 User Company Types Interviewed 3 -2 Trade Associations Interviewed 4 	
<hr/>		
II	<ul style="list-style-type: none"> -1 The U.S. EDI Services and Software Market—1990-1995 8 -2 Future Growth Opportunities of EDI 9 -3 Will a "Macro" 80-20 Rule Limit EDI Growth? 10 -4 The Microcomputer Platform is the Most Lucrative EDI Software Market 11 	
<hr/>		
III	<ul style="list-style-type: none"> -1 Definition of EDI 16 -2 Benefits of EDI 17 -3 Benefits of a Third-Party VAN/RCS 20 	
<hr/>		
IV	<ul style="list-style-type: none"> -1 EDI Input-Output Matrix (Economy-wide) 27 -2 EDI Input-Output Matrix (Manufacturing and Distribution Sectors) 28 -3 How to Read the EDI Input-Output Matrix 29 	
<hr/>		
V	<ul style="list-style-type: none"> -1 Statistical Quantities that Characterize EDI Usage 34 -2 Difference Between EDI Users and EDI Trade Relationships 35 -3 Relationship Between Total EDI User Population and Potential EDI Trading Relationships 36 -4 EDI Users Versus Trading Relationships 37 -5 Distribution of Customer Revenues by Percentile for EDI Network Services 39 -6 Leading EDI VANs—1990 40 -7 Leading EDI Software Vendors—1990 41 	



Exhibits (Continued)

V	-8 U.S. EDI Network Services Market—1990-1995	42
	-9 U.S. EDI Software Market—1990-1995	43
	-10 U.S. EDI Professional Services Market—1990-1995	43
	-11 U.S. EDI Services and Software Market—1990-1995	44
	-12 EDI Market Growth by Delivery Mode	45
	-13 The U.S. EDI Services and Software Market—1990-1995	45

VI	-1 Players in the EDI Market Wear Many Hats	50
	-2 Trends in EDI Software Offerings	52
	-3 Network versus Software Functionality	53
	-4 Vendors of Communication Gateway/EDI Server Software	54
	-5 Use of Communication Gateway Software by EDI Users	55
	-6 The Three-Tiered Market for Switching Software	56
	-7 User Preference for Real-Time EDI	57
	-8 Event-Driven EDI Architecture	58
	-9 Vendors of EDI-Ready Software Applications	59
	-10 Vendors of EDI Translation Software for Less than \$1,000	60
	-11 Non-Vendor Sources of EDI Software	61
	-12 EDI Users Become Software Vendors	61
	-13 Significant Acquisition Activity Relating to EDI Software	62
-14 Translation Platforms	63	
-15 Trends in Network Services	64	
-16 Prominent EDI Network Acquisitions	65	
-17 International EDI Usage	66	
-18 Interconnection Usage	67	
-19 Leading VAN/Bank Alliances	68	
-20 Advanced versus Basic Transport Services	70	

VII	-1 Statistics on EDI in the Auto Industry	82
	-2 EDI in the Printing/Publishing/Paper Industry	83
	-3 EDI on Pubnet	86
	-4 EDI in the Retail/Apparel/Textile Trading Community	87
	-5 Retail/Apparel/Textile Trading Community Profile	92
	-6 Leading VANs for Hardlines	93
	-7 Leading EDI Users and Vendors in the Electrical Manufacturing Industry	94
	-8 EDI Users and Network Providers in Electronics	95
	-9 Oil Industry EDI Profile	98
	-10 EDI in the Grocery Industry	99



Exhibits (Continued)

VII	-11 Grocery EDI Profile	103
	-12 EDI in the Chemical Industry	105
	-13 EDI Use in the Chemical Industry	106
	-14 Groups within the Transportation EDI Trading Community	107
	-15 EDI Users and Networks in Trucking	111
	-16 EDI Applications in the Railroad Industry	112
	-17 EDI Use by Railroads	113
	-18 Interfaces in International Trade—Partial List	115
	-19 EDI in the Utility Industry	124
	-20 EDI Use in the Utility Industry	125
	-21 EDI Use in the Communications Industry	126
	-22 Film Industry Transaction Sets	126
	-23 Electronic Data Interchange in the Film Industry	129
	-24 EDI, Financial EDI and Electronic Funds Transfer	131
	-25 U.S. Electronic Trade Payment Transactions—Selected Data	133
	-26 Data Formats for Payment Information	134
	-27 Leading Financial EDI Software Vendors	136
	-28 Leading Users and Vendors of Financial EDI	139
	-29 IVANS Revenues	143
	-30 Federal EDI Programs	145
	-31 Electronic Benefits Transfer—Food Stamps	148
	-32 EDI in Construction	152
	-33 EDI in Education	153
	-34 Hospital Industry Trading Partners	158
	-35 EDI in the Pharmaceutical Industry	162
	-36 Leading Users of EDI in Pharmaceutical Manufacturing and Distribution	164
	-37 EDI in the Medical/Surgical Supply Chain	165
	-38 Service Industries Adopting EDI	167

VIII	-1 EDI Vendor Recommendations	174
-------------	-------------------------------	-----

B	-1 EDI Market Forecast by Delivery Mode, 1990-1995	181
----------	--	-----

C	-1 Forecast Reconciliation	183
----------	----------------------------	-----

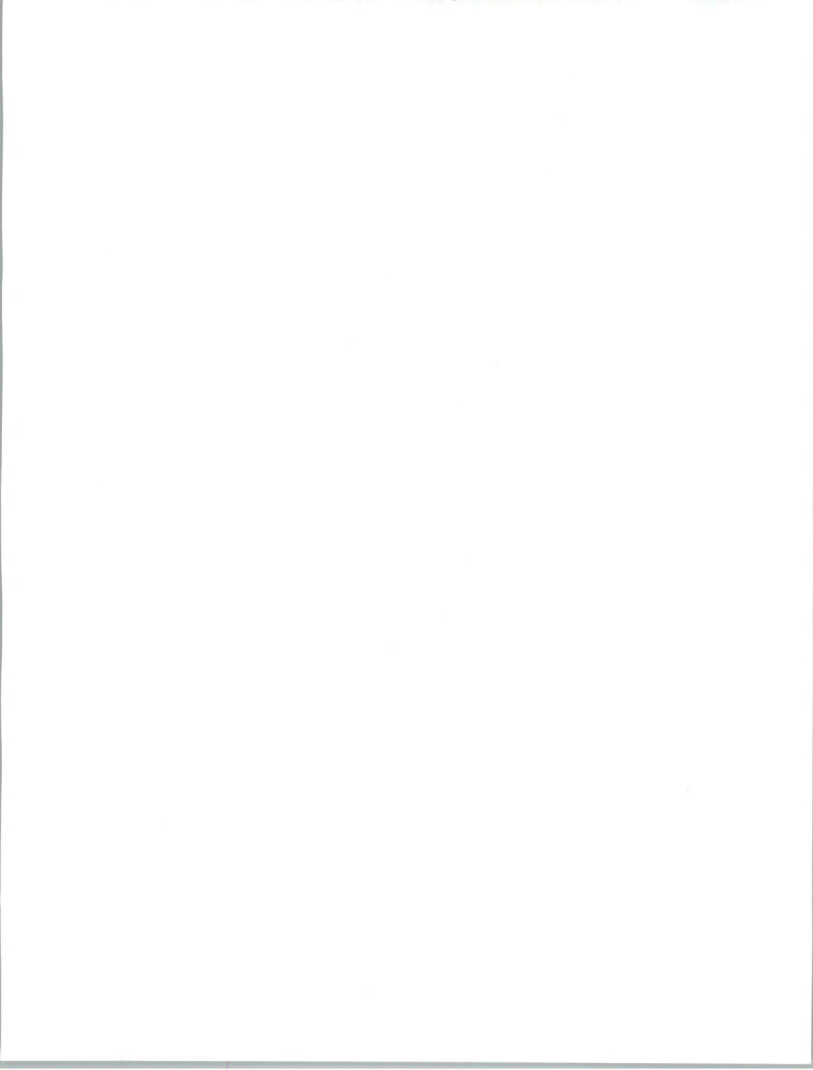





Introduction







Introduction

This report, produced as part of INPUT's Electronic Data Interchange Program, examines the EDI market in the United States.

A

Scope of the Report

INPUT defines EDI as the application-to-application exchange of intercompany business data in structured, standard data formats. Business data typically includes invoices, purchase orders, shipping documents, and other information that companies exchange with each other during the course of commercial transactions.

This report focuses on third-party EDI service and software markets in the United States and excludes consumer applications such as electronic shopping, electronic banking, automatic teller networks (ATMs), point-of-sale (POS) data/funds transfers, airline reservation systems, credit authorization systems, and other captive networks that are used for transactions between two parties. Although these systems do use structured data formats to transfer information, the applications generally use specialized terminal devices to communicate with dedicated computers, are not computer-to-computer, application-to-application implementations, and use proprietary data formats rather than public standards.

The report is designed to assist vendors in:

- Identifying new markets and product opportunities
- Assessing product and marketing risk exposure
- Allocating research, development, and operational resources
- Gaining insight into market developments

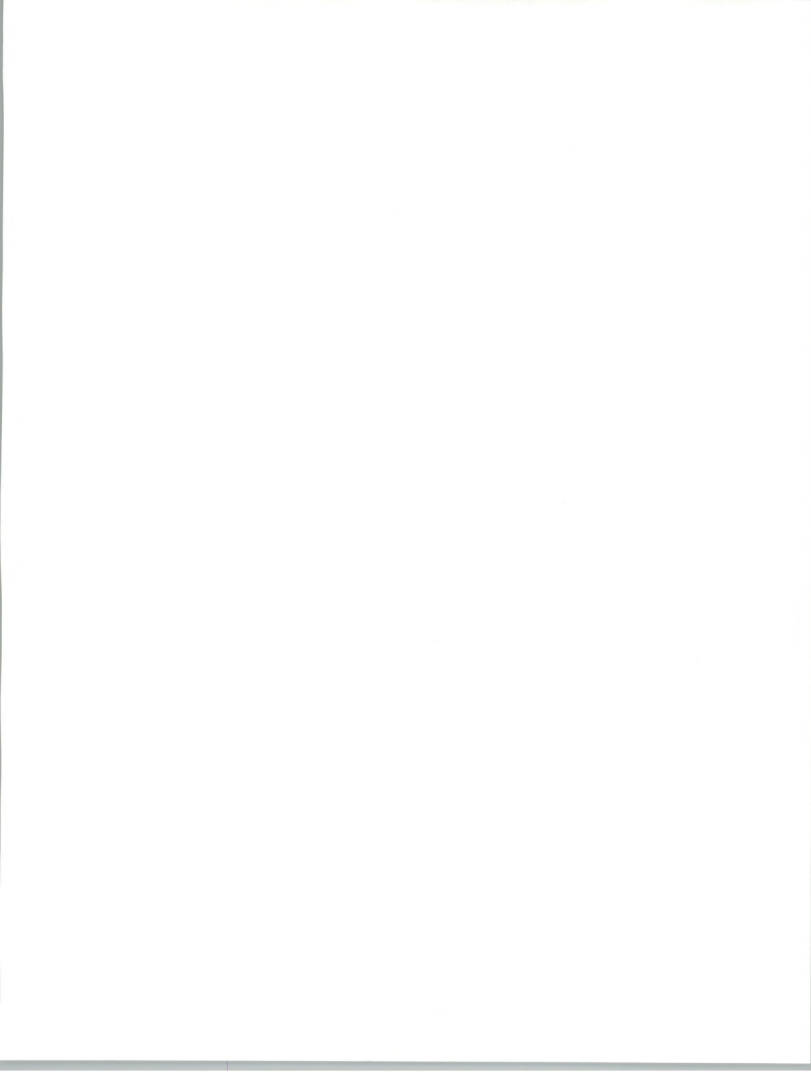

The report is secondarily an aid to EDI users by helping them to

- Become familiar with the various applications of EDI throughout industries and sectors of the economy
- Understand product trends for EDI and how other users are implementing EDI systems
- Become familiar with the vendors of the EDI market

This report reviews the state of EDI use within the economy, how it is being applied in 35 industrial/commercial sectors, the concerns and practices of EDI users today, how much users are spending on EDI products and services, how much the market for these products and services will grow through 1995, who the leading vendors of these products and services are, and the features and characteristics of these products and services.

B

Data Collection

INPUT prepared this report using data gathered from interviews of EDI users, representatives of industry trade associations, vendors of EDI products and services, product literature, and published reports of the media.

1. Interviews

a. EDI Users

INPUT interviewed a total of 50 user companies. Spokespersons at these companies were directly involved in the company's EDI program and were typically EDI project directors, EDI systems analysts, or functional managers (such as purchasing).

A copy of the questionnaire is in Appendix D.

Exhibit I-I lists the kinds of companies interviewed for this report.



EXHIBIT I-1

User Company Types Interviewed

Industry Type	Number of Companies
Discrete manufacturing	14
Process manufacturing	6
Distribution (retail and wholesale)	8
Transportation	5
Utilities	2
Communications	4
Finance	3
Government	3
Agriculture	1
Education	1
Healthcare	1
Services	2
Total	50

b. Associations

INPUT interviewed 23 trade associations and EDI industry-specific associations for this report. A basic questionnaire was used for the interviews, which were open-ended, lengthy discussions and in-depth explorations of ad hoc issues.

Exhibit I-2 lists the industry trade groups interviewed for this report.

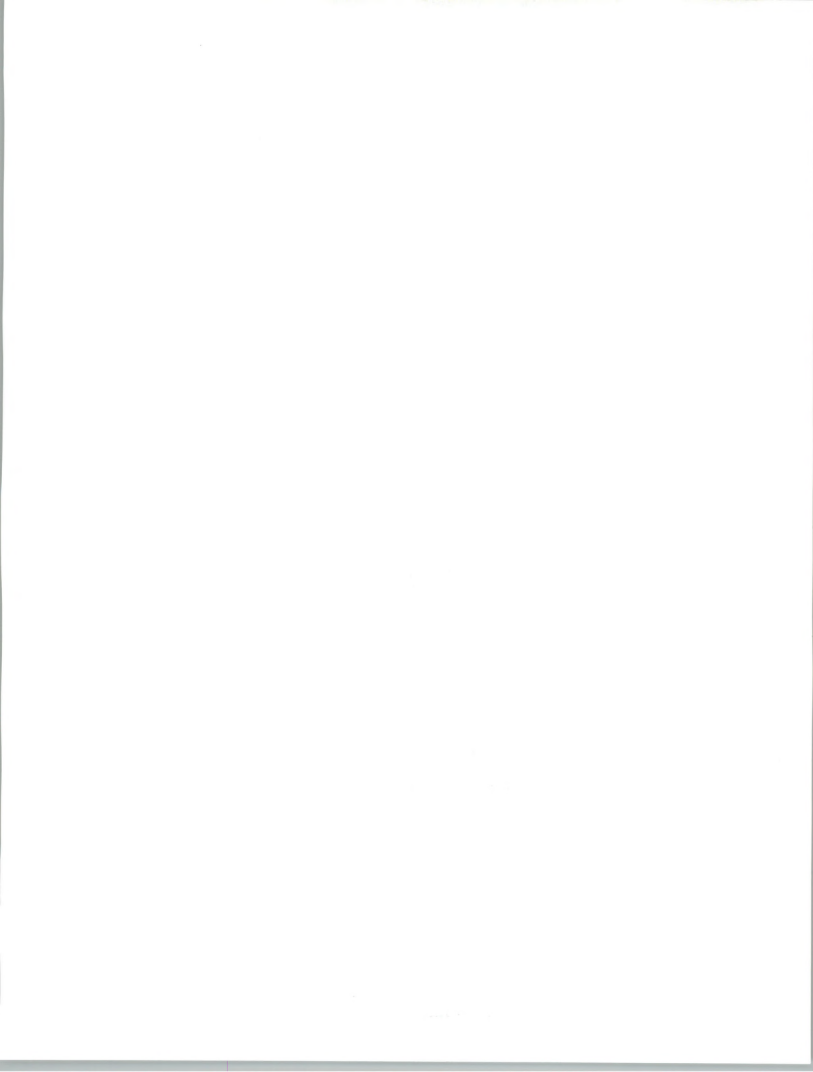
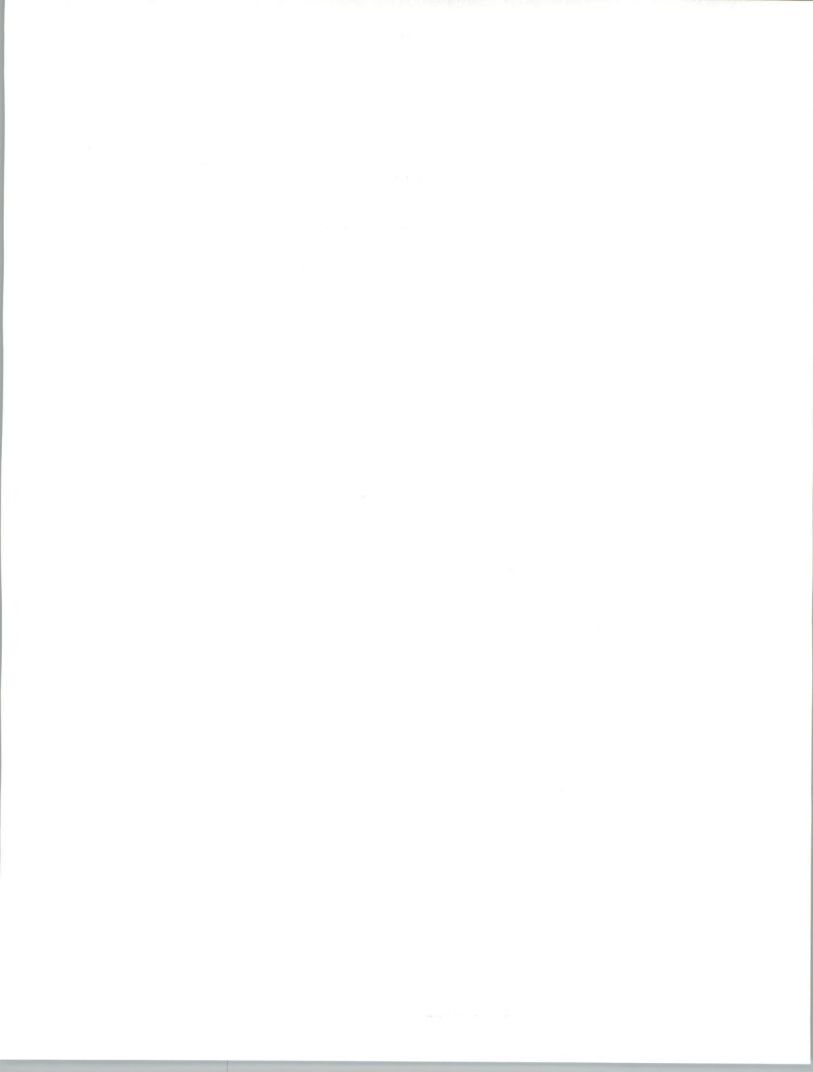

EXHIBIT I-2

Trade Associations Interviewed

- Health Insurance Business Communications Council
- National Wholesale Druggists Association
- National Electrical Manufacturers Association
- Electronics Industries Data Exchange (EIDX)
- Aerospace Industries Association of America
- National Automated Clearinghouse Association (NACHA)
- Cal Western Automated Clearinghouse
- National Customs Brokers and Forwarders Association of America
- Automobile Industry Action Group (AIAG)
- Voluntary Interindustry Communication Standard (VICS)
- American Trucking Association
- American Association of Railroads
- Construction Industry Institute
- Uniform Code Council
- Chemical Industry Data Exchange (CIDX)
- Utility Industry Group
- Printing Industries of America
- Graphic Communication Association
- American Paper Institute
- National Association of Purchasing Management
- Insurance Value-Added Network Service Inc. (IVANS)



c. Vendors

INPUT is continually canvassing vendors of EDI services and products. Such communications serve many purposes: to serve INPUT client consulting requests, to report on news in INPUT's *EDI Reporter International*, to stay current with developments in the EDI world, to update INPUT's information bank, and to gather data for this and other reports.

Vendor communications take place over the phone, in person during personal visits by INPUT and/or the vendor, and in person during EDI conferences and meetings. INPUT maintains active contact with over 25 software vendors and 15 services companies that participate in the EDI market.

2. Product, Service, and Industry Analysis

INPUT collected and analyzed information on EDI services and vendors planning EDI services, and reviewed secondary research sources. Additionally, INPUT monitored industry publications, attended conferences, and secured other relevant research data to inform this study.

3. Related Program and Custom Research

INPUT has been engaged in several consulting projects concerning EDI and has published a variety of other publicly available research reports on EDI. Although no proprietary information of the custom research is revealed, the general industry knowledge gained is presented in this report.

C

Report Structure

The report is structured as follows and addresses the following topics:

Chapter II is an Executive Overview of the entire study.

Chapter III is a background and tutorial on EDI that reviews the rationale, product and service needs, and implications of companies that implement EDI.

Chapter IV presents a new methodology for examining EDI throughout the economy, the EDI Input-Output Matrix.

Chapter V contains market forecasts and user expenditure estimates for services and software and presents an overall market forecast.

Chapter VI reviews the trends in vendor offerings in software, network and professional services.

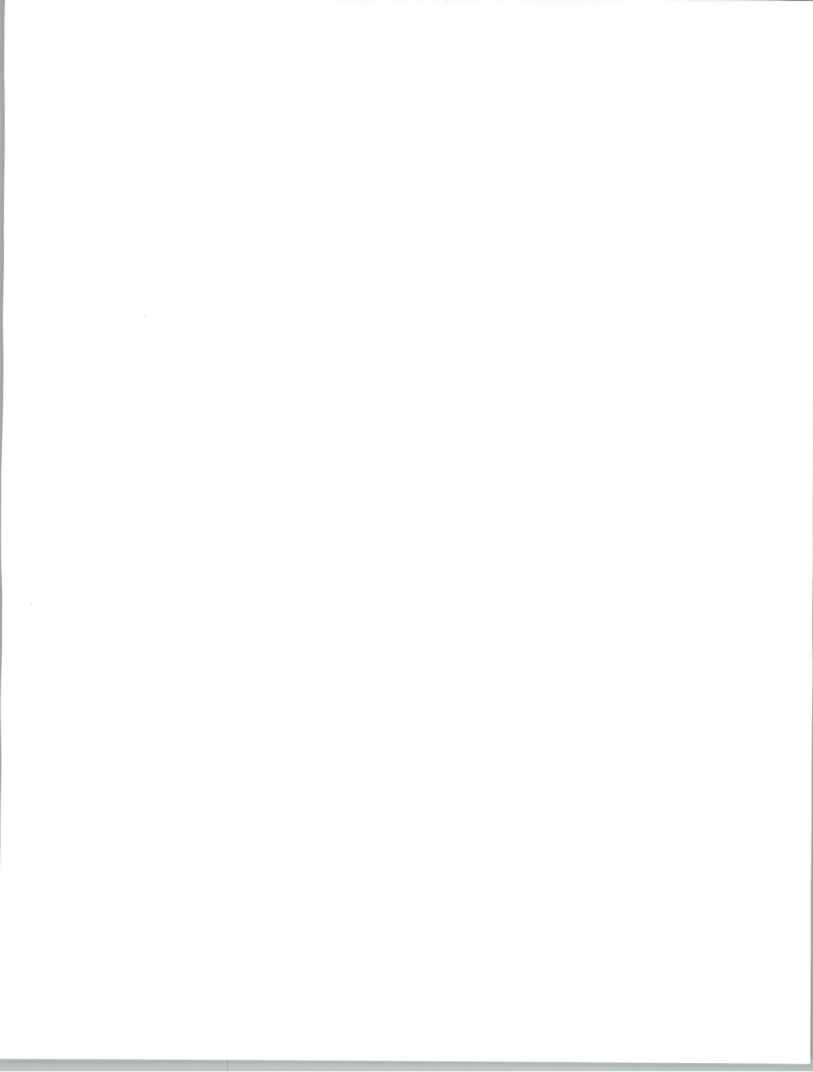

Chapter VII is a comprehensive account of EDI applications throughout 35 sectors of the economy.

Chapter VIII presents conclusions and recommendations for EDI users and vendors.

Appendix A defines terms used in this report.

Appendix B contains the forecast data base.

Appendix C contains the reconciliation between INPUT's 1989 forecast for the EDI market and the 1990 forecast.

Appendix D contains the questionnaire administered to EDI users.

D

Related INPUT Reports

This study is one of a continuing series focused on EDI. Other reports in the series include:

- *EDI: Business Integration Issues (1990)*
- *Advanced EDI Services (1989)*
- *EDI Intertrends—Western Europe (1989)*
- *EDI Standards Reference Guide (1989)*
- *EDI Implementation Case Studies (Volume I and II) (1988, 1989)*
- *U.S. EDI Federal Markets (1989)*
- *EDI and X.400 (1988)*
- *North American EDI Service Provider Profiles (1988)*
- *North American EDI Software Provider Profiles (1988)*
- *EDI and Professional Services (1988)*
- *EDI Software Products: Issues, Trends, and Markets (1988)*

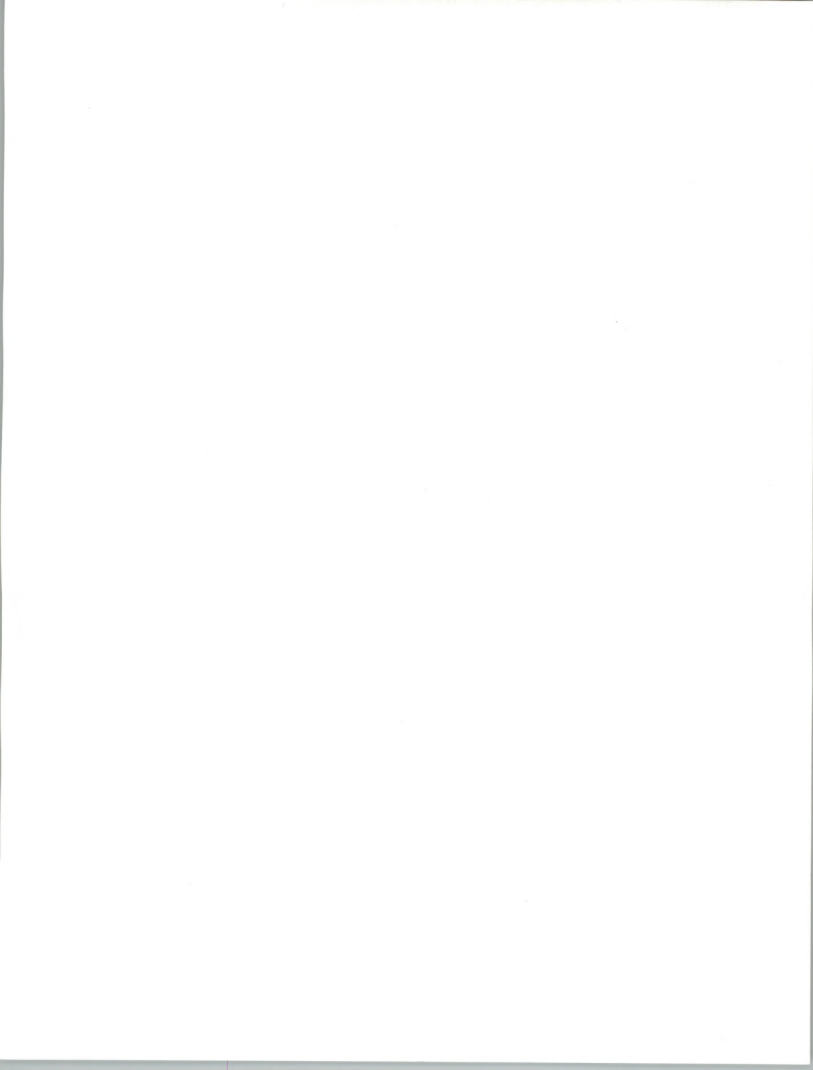



Executive Overview







Executive Overview

A

Market Directions

EDI applications are proliferating in all sectors of the economy. The proliferation has increased since 1988. New industries (such as services, construction, education, entertainment) are adopting EDI. Industries that had some form of electronic data exchange (such as airlines, health care, insurance) are revamping systems to fit in with the newly stabilizing X12 and EDIFACT standards environment.

Despite a proliferation of applications, absolute growth in the number of EDI-using companies is slow. INPUT estimates 5,000 U.S. companies will adopt EDI in 1990 and a similar number will adopt it in 1991. User expenditures on EDI network services, software, and professional services will be \$117 million in 1990. It is expected to rise to \$276 million by 1995 at a compound annual growth rate of 19%, as shown in Exhibit II-1.

As a result of the slow growth, the EDI marketplace has experienced a consolidation of vendors through merger and acquisition activity which will probably continue, especially among software vendors. Network providers have consolidated (British Telecom/McDonnell Douglas Tymnet and AT&T/Istel/Western Union). Software providers have consolidated (Sterling Software/Metro Mark and TSI International/Transsettlements). And—not due to EDI dynamics but nonetheless important to note—professional services firms have consolidated (Ernst & Whitney/Arthur Young and Deloitte, Haskins, and Sells/Touche-Ross). Approximately 40 EDI software vendors are vying for a \$25 million market (in 1990). Consolidation, attrition, and/or continued small sales will remain common in the EDI software vendor community.

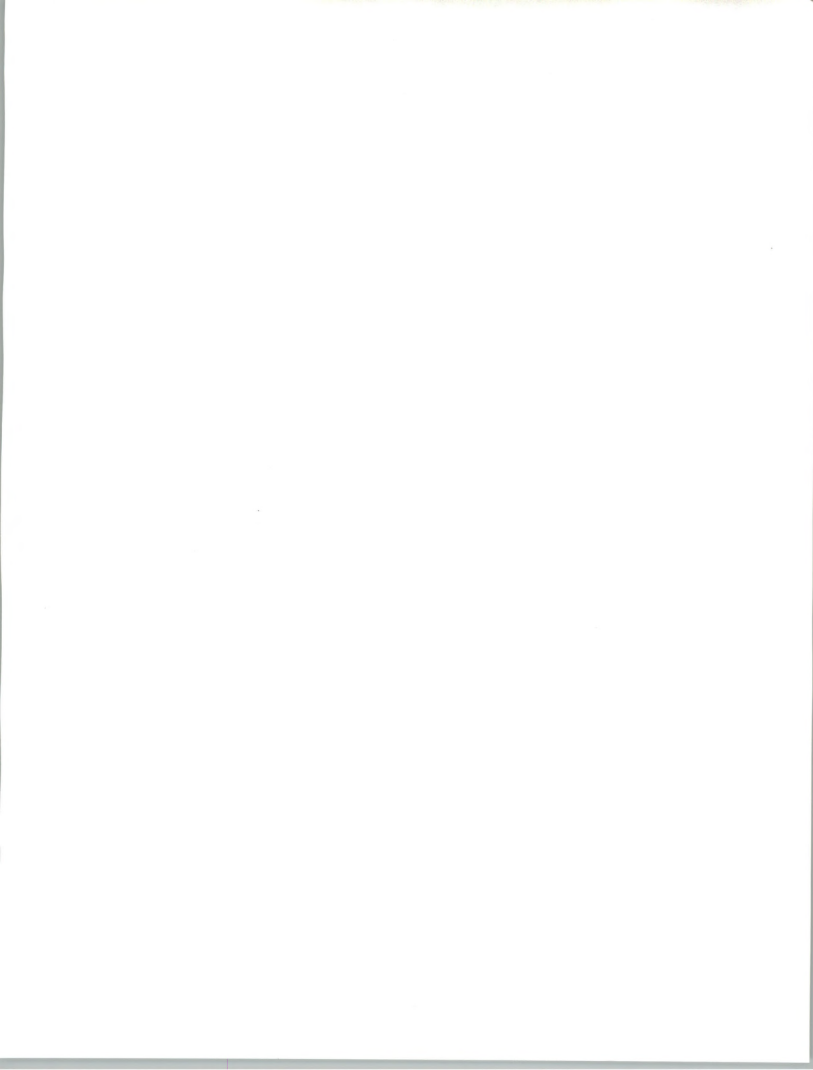
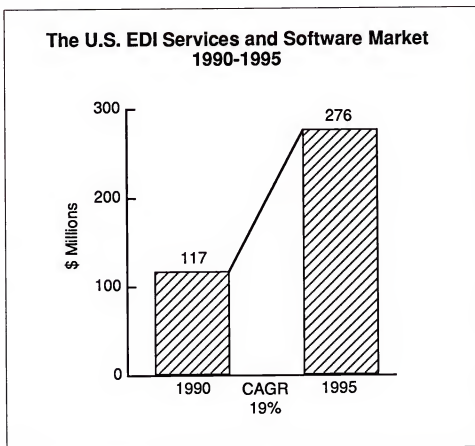

EXHIBIT II-1

**B****Market Opportunities**

Despite slow growth in absolute numbers, the EDI market is still wide open to growth in other dimensions. Such dimensions include: number of trading relationships (different than absolute number of users), advanced services, new EDI applications, and systems integration (see Exhibit II-2). To remain profitable, vendors must pursue these other dimensions by enhancing existing offerings, developing new offerings, and expanding markets. Already new advanced EDI network services are being offered such as financial EDI, transaction data bases, sending CAD/CAM files attached to EDI documents, media conversion services, internetworking, and international connections. New EDI translation software offerings that are redefining EDI software design are EDI servers/communication gateways, event-driven couplings between translator and application, and real-time EDI systems.

Growth in EDI will occur within and emanate from industries that are already doing EDI or are core economic industries. Transportation, distribution, and auto manufacturing are established EDI-using industries that will experience accelerating growth internally and with industries

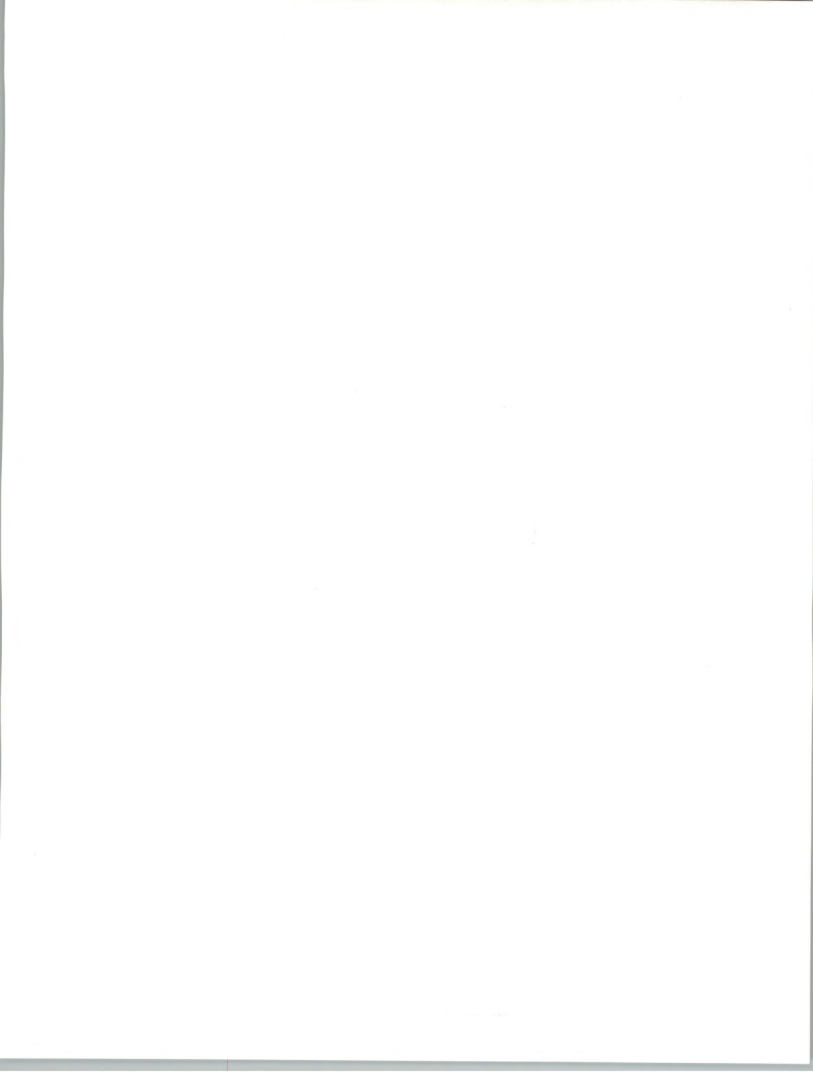

EXHIBIT II-2

Future Growth Opportunities of EDI

Opportunities	Network Providers	Software Vendors	Professional Service Firms
Expanding number of EDI users	✓	✓	✓
Expanding EDI trade relationships	✓		✓
Advanced services			
Data bases	✓		
Funds transfers	✓	✓	
Graphics exchange	✓	✓	
Real-time EDI	✓	✓	
EDI servers/communications gateways		✓	
Systems integration services	✓	✓	✓
New EDI applications (vertical markets)	✓	✓	✓

connected to them. Banking/finance and petrochemicals are budding EDI industries that, because they play such central roles to all other industries, should become EDI-intensive.

Despite the low marginal value to a company of bringing up its smallest trading partners, some vendors and users are pushing to bring up all of a company's trading partners on EDI. Inexpensive micro-based translation software, trading partner turnkey implementation services, and conversion services (EDI to fax, post, E-mail) are being offered by vendors in an attempt to help companies bring up all trading partners. Whether this is an economically sound strategy remains to be seen.

Hub-and-spoke topologies and "80-20" implementation practices suggest there may be an upper limit to the number of EDI-using companies in the economy. Even in relatively EDI-intensive industries such as grocery, only hundreds of companies conduct EDI out of the many thousands of

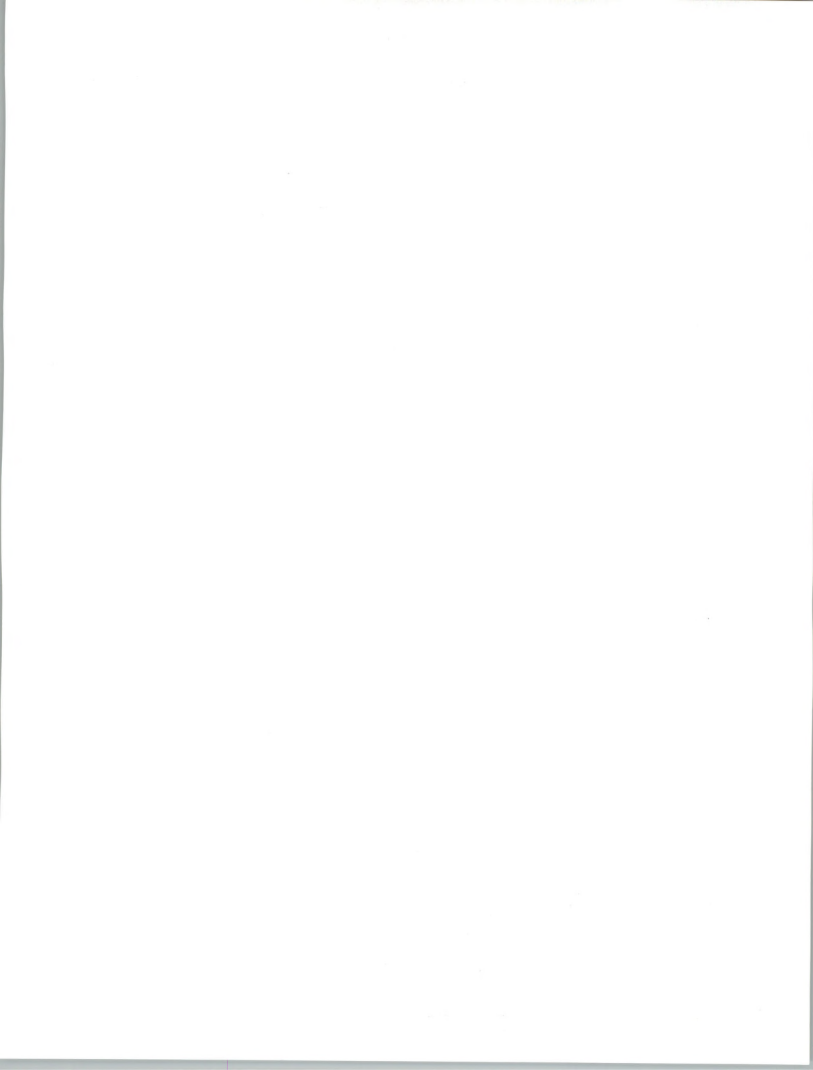

companies that trade in the industry. Time may show that EDI is used just to facilitate the central trade flows between major corporations and agencies. Most industries are dominated by a handful of large companies. These companies, if they choose to adopt EDI, begin by linking with their key trading partners (that 20% responsible for 80% of the business). Of the \$5.1 trillion GNP, the Forbes 500 accounted for 62% and Fortune 500 accounted for 41%. If only a handful of companies are responsible for most of the value-adding going on in the economy and these companies conduct EDI with only 20% of their trading partner base, then the total number of EDI-using companies may remain in the low 10,000s. This upper limit to the number of EDI-potential companies can be seen as a result of a "macro" 80-20 rule, as seen in Exhibit II-3.

EXHIBIT II-3

Will a "Macro" 80-20 Rule Limit EDI Growth?

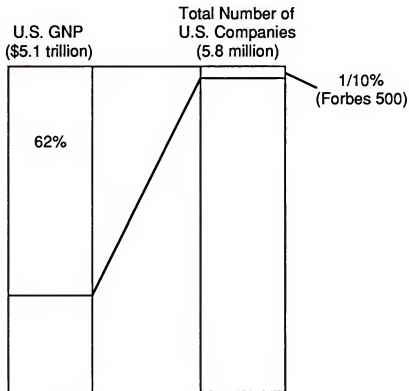

By various estimates, a small proportion of all U.S. businesses account for a majority of U.S. output. If these few companies implement EDI according to an 80-20 rule, then the overall number of EDI users in the economy will be in the low ten thousands.

the same time, the number of species of plants and animals that are found in the same place is also increased. This is because the more diverse the environment, the more niches there are for different species to occupy. For example, a forest with many different types of trees and plants will support a larger number of different species of birds and insects than a forest with only one type of tree. Similarly, a body of water with many different types of plants and animals will support a larger number of different species of fish and other aquatic life than a body of water with only one type of plant and animal.

Another important factor in determining the number of species in a community is the amount of energy available to the organisms. Energy is the fuel that drives all life processes, and the more energy that is available, the more organisms can survive and reproduce. For example, a large body of water with a high flow of energy from the sun will support a larger number of species than a small body of water with a low flow of energy. Similarly, a large forest with a high flow of energy from the sun will support a larger number of species than a small forest with a low flow of energy.

Finally, the stability of the environment is also an important factor in determining the number of species. A stable environment, where the conditions are relatively constant over time, will support a larger number of species than an unstable environment, where the conditions change frequently. For example, a forest with a stable climate and a long history of existence will support a larger number of species than a forest with a highly variable climate and a short history of existence. Similarly, a body of water with a stable temperature and a long history of existence will support a larger number of species than a body of water with a highly variable temperature and a short history of existence.

In summary, the number of species in a community is determined by a combination of factors, including the diversity of the environment, the amount of energy available, and the stability of the environment. These factors interact in complex ways to determine the number of species that can survive and reproduce in a given place. Understanding these factors is important for conservation efforts, as it helps us to identify the conditions that are most favorable for biodiversity and to develop strategies to protect and restore these conditions.

Financial EDI (electronic corporate-to-corporate payments) is growing at approximately 23% per year. This growth is driven more by a fixed number of users increasing their electronic payments and collections than by an increasing number of users keeping their payments/collections constant. Only 22% of INPUT's surveyed user base conduct some form of financial EDI. Financial EDI represents a tremendous opportunity for both vendors and users. Not only in the area of payments, but also in factoring, equipment leasing, insurance claims processing, mortgage lending, international letters of credit, and cash management there are possibilities for EDI that are underway.

The biggest market for EDI translation software is—and will continue to be—in packages that run on microcomputers. The mainframe software market is limited by the number of mainframe installations. Midrange platforms, though seemingly more popular among the mainstream EDI industries of manufacturing and distribution, are not widely used, according to user research. Micros are often used as front-ends to larger CPUs. Although more midrange translation packages may have been sold than mainframe packages, the margins on mainframes are higher. Overall, mainframe sales exceed midrange sales despite having fewer installations. See Exhibit II-4. Despite being the largest in total sales, the micro-computer EDI software market is overcrowded with competitors. Many companies have less than a million dollars in sales of EDI software. Consolidation of vendors through mergers, acquisitions and attrition is expected.

EXHIBIT II-4

The Microcomputer Platform is the Most Lucrative EDI Software Market

Platform	Estimated Total Installations	1990 Market Size (\$ Millions)
Micro	15,000	12.2
Midrange	1,800	6.1
Mainframe	1,195	7.3

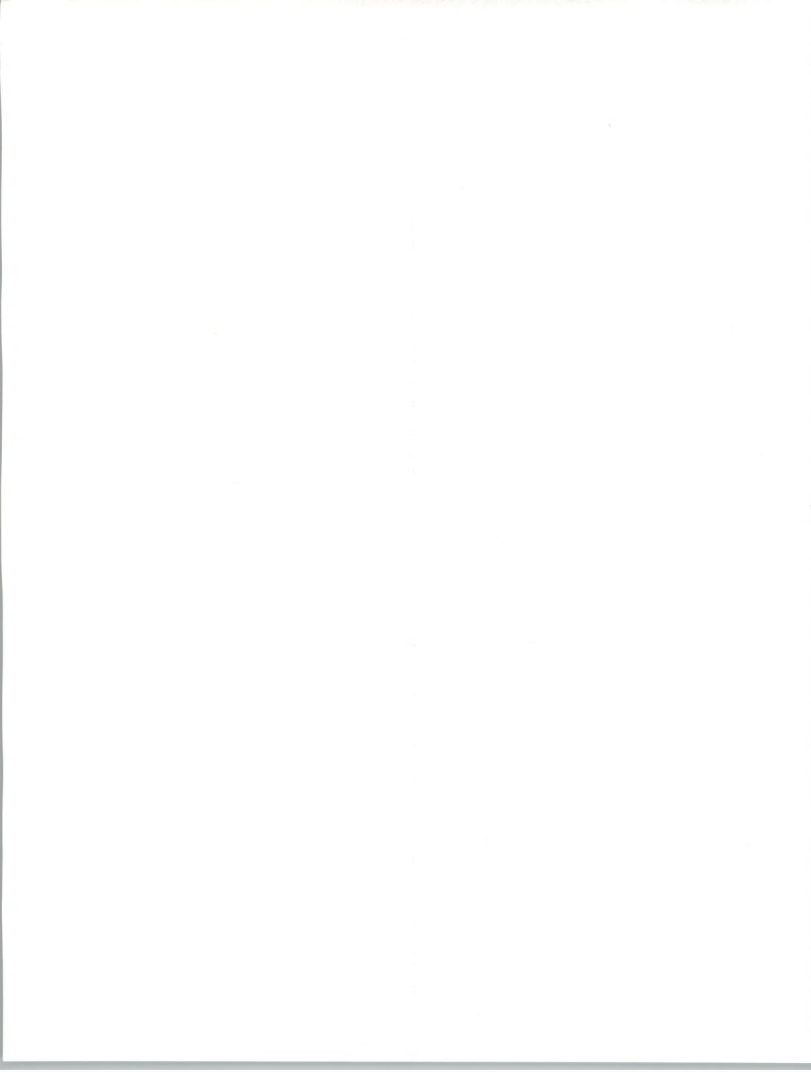

C

User Issues

EDI users are experiencing difficulty in integrating EDI with internal systems. The technical complexity of integration combined with limited in-house MIS resources and an uncertainty as to whether EDI economically makes sense, results in EDI getting second priority in systems development. To move EDI into a priority position, business managers must look at EDI as just one component of a larger strategy. More than just technical issues are involved: namely, business organization and strategic issues need to be addressed. Vendors of EDI products and services need not only to consider new technical solutions to integrating EDI with a customer's internal systems, but also must address the business needs of users.

EDI data formats are consolidating into two general standards families, but industry-specific "flavors" are still retained. Industry-specific data formats that were developed in the 1970s and early 1980s (such as the Uniform Communication Standard, Warehousing Industry Network Standard, and the Transportation Data Coordinating Council standards) are being turned over to the ANSI X12 Accredited Standards Committee for management and future development. EDIFACT and ANSI X12 will peacefully coexist despite having different syntaxes. There is a large overlap of representatives on X12 and EDIFACT standards development committees, which will help in aligning the two standards families. The multiplicity of data format standards is not diminishing the vitality of EDI growth. INPUT believes that multiple standards will continue to exist for the next five years at least. Each standard will be used where it is most appropriate: TDCC in transportation, EDIFACT in international trade, and ANSI X12 for generic domestic commercial exchanges.

The issues and grievances over standards among users are not over which family of standards to adopt (X12 or EDIFACT), but rather whether a trading partner fully or only partly complies with a particular transaction set's syntax. Often companies do not use mandatory data elements, fill in elements with syntactically inappropriate data, disregard data elements, and otherwise use transaction sets differently from all other trading partners of a given company.

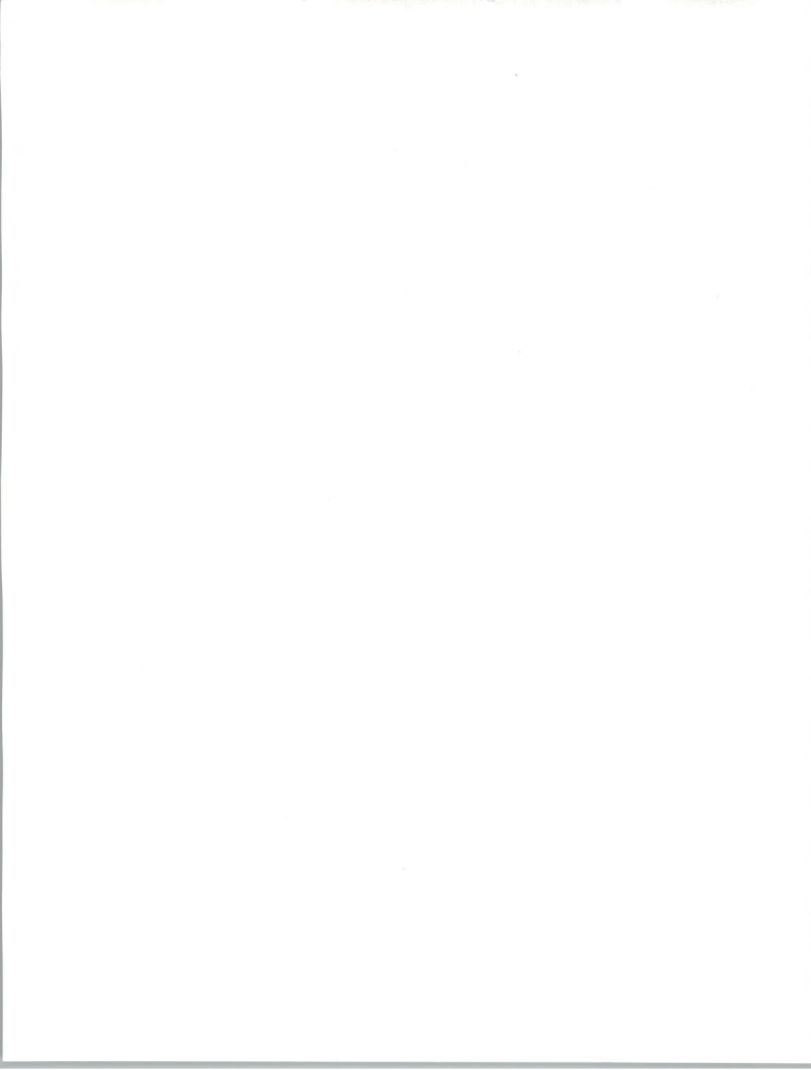

D**Conclusions**

The economics of EDI (as well as all information systems technologies) are not yet clearly understood, and this lack of understanding is partly responsible for inhibiting the growth of EDI. Such an understanding will come only after many years of business experimentation and evolution. EDI reorganizes businesses, industries, and economies. It changes unities within the macroeconomic system: buyers and sellers become more integrated; industries become integrated as a result of collectively defining standards; vendors are often users; users are often vendors; competitors form consortia (such as in the case of transaction data bases); within a single company departmental boundaries and job descriptions are redefined (because properly implemented EDI touches all functional groups of a company—sales, manufacturing, accounting, shipping—and buyers, product designers, production line workers, sales personnel, and accounting workers become a single team).

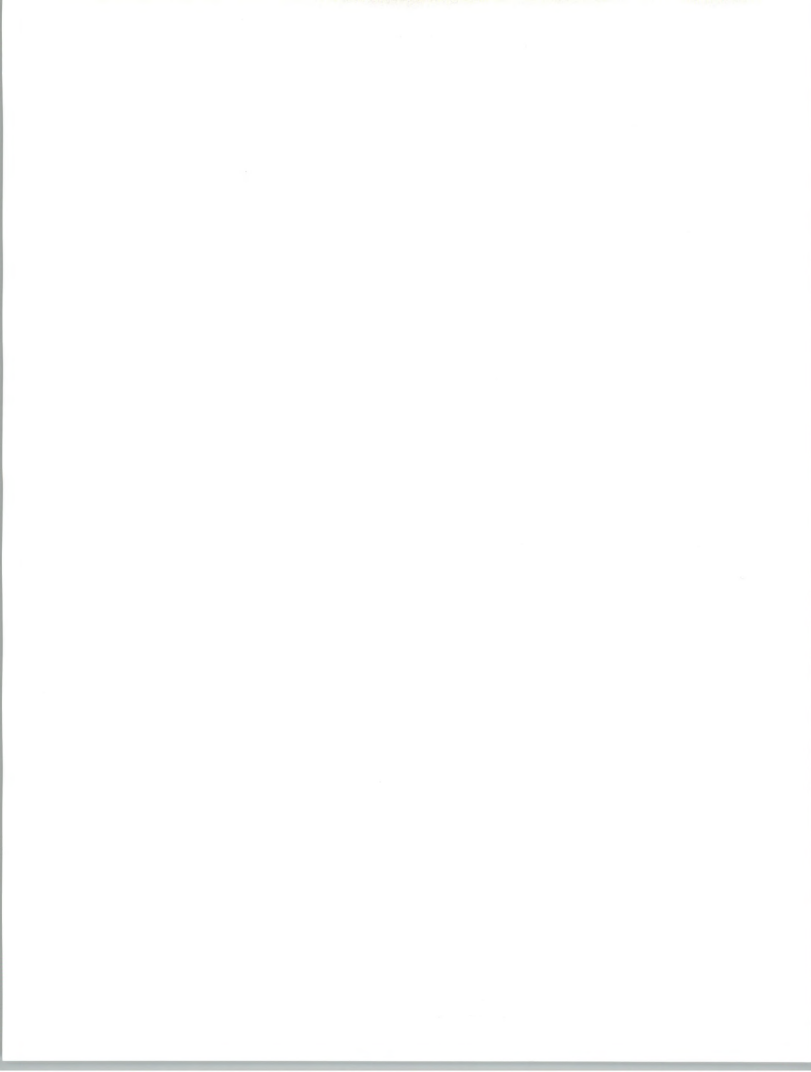

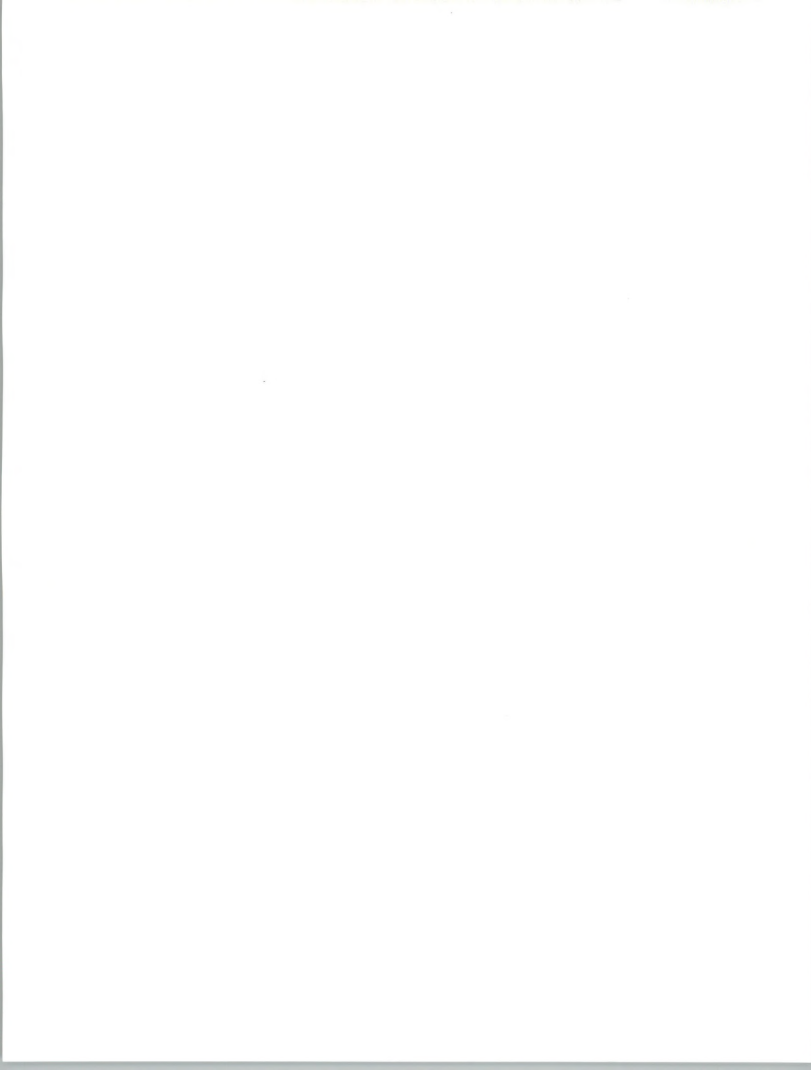



Background on EDI



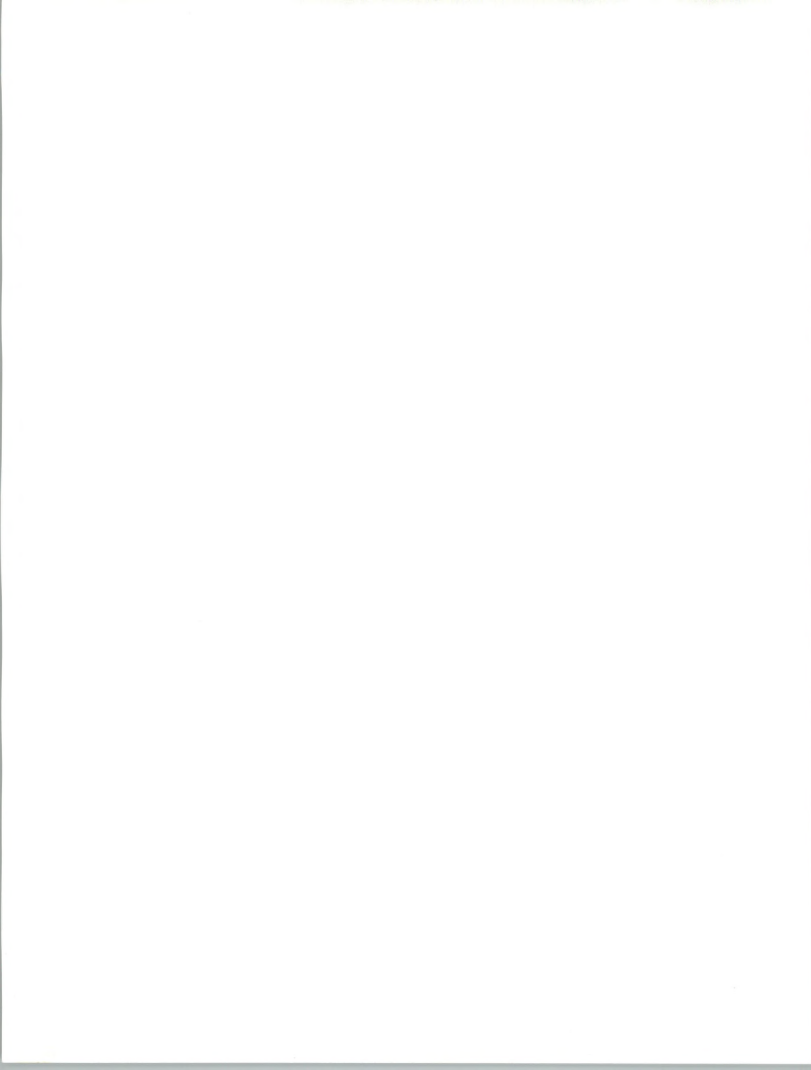



Background on EDI

A

Introduction

Today, in the United States, virtually all large and many smaller companies have installed computerized systems for routine business operations such as order processing, inventory control, accounting, and so on.

A business will use these computer applications to prepare business documents such as purchase orders, invoices, shipment bills of lading, etc. Typically, the documents are printed out on paper and mailed to the appropriate trading partner of the company. For example, purchase orders are sent to suppliers, invoices to customers, bills of lading to transportation vendors, and payment instructions to the company's bank.

The company's trading partners receive these paper documents and, in most cases, input the data into their respective computer systems. In other words, the data generated in one company's computer system is temporarily transferred to paper so that the data can then be re-entered into another company's computer. A study by General Electric found that 70% of all data entered into computers is generated by other computers.

Electronic data interchange was invented to obviate the need for paper data transfer methods (and its associated high labor intensiveness and cost).

The rationale of EDI is to allow the direct application-to-application exchange of data representing business documents.

The exchange of data is sometimes handled by physically shipping computer tapes or diskettes. Increasingly, data networks are being used.

The first part of the document discusses the importance of maintaining accurate records of all transactions. It emphasizes that every entry, no matter how small, should be recorded to ensure the integrity of the financial data. This includes not only sales and purchases but also expenses and income. The document provides a detailed list of items that should be tracked, such as inventory levels, accounts payable, and accounts receivable. It also outlines the procedures for recording these transactions, including the use of journals and ledgers. The second part of the document focuses on the reconciliation process. It explains how to compare the company's records with bank statements and other external sources to identify any discrepancies. This process is crucial for detecting errors and preventing fraud. The document provides a step-by-step guide to performing a reconciliation, including how to identify and investigate any differences. The final part of the document discusses the importance of regular audits. It explains that audits are necessary to ensure that the financial records are accurate and that the company is complying with all applicable laws and regulations. The document provides a list of common audit procedures and offers advice on how to prepare for an audit. It also discusses the role of the auditor and the importance of maintaining a good working relationship with them. Overall, the document provides a comprehensive guide to financial record-keeping and reconciliation, and is an essential resource for any business owner or manager.

B

The Role of Standards Rarely do two businesses have applications that format the data of their business documents identically. Furthermore, different computer systems (with different brands of hardware, software, telecommunication protocols, etc.) prevent applications from being connected and communicating with each other smoothly.

Thus, to allow computer systems to directly tie into each other, the data formats that represent the business documents must be standardized. Each organization is then free to build its particular applications to a common standard. The data is machine processable by any other application that has been built to the standard. Exhibit III-1 specifies the technical definition of EDI.

EXHIBIT III-1

Definition of EDI

EDI is the application-to-application exchange of intercompany business data in structured, standard data formats

Despite the availability of public standards, however, there is much EDI that is conducted using proprietary data formats. Usually a dominant company requires its dependent suppliers to accept the data formats of its systems, with the penalty to the supplier being the potential loss of business if it doesn't comply.

C

Benefits of Using EDI Companies using EDI benefit from improved use of labor, inventories, liquid capital (funds), and facilities.

Specific benefits of EDI are listed in Exhibit III-2.

EXHIBIT III-2

Benefits of EDI

- **Data Keying**—EDI reduces or eliminates redundant data entry.
- **Errors**—EDI eliminates keying errors; eliminates human interpretation/classification errors; and eliminates filing errors and lost documents.
- **Filing**—EDI replaces paper document filing with electronic files. It eliminates the need for human filing and file retrieval and reduces total space for computer files.
- **Paper Forms**—EDI reduces paper forms, especially multipart carbons going to many departments.
- **Postage**—EDI replaces mailed documents with data transmissions.
- **Invoicing**—EDI eliminates the need to invoice, since payment can be automatically triggered upon receipt of goods (evaluated receipt settlement).
- **Payment**—EDI replaces checks with electronic payment.
- **Accounts Receivable**—EDI automates the cash application function, improves control, and eliminates the billing/invoicing function via evaluated receipt settlement.
- **Accounts Payable**—EDI automates the entire payments process, including payment and remittance creation; it eliminates invoice validation via evaluated receipt settlement.
- **Inventory**—EDI reduces order lead time and order confirmation delay; it facilitates just-in-time inventory and the maintenance of lower levels of costly inventory. It reduces out-of-stock situations and allows better control overall.
- **Customer Service**—EDI allows for more responsiveness to customers and direct sales connections, and encourages lasting relationships with customers.

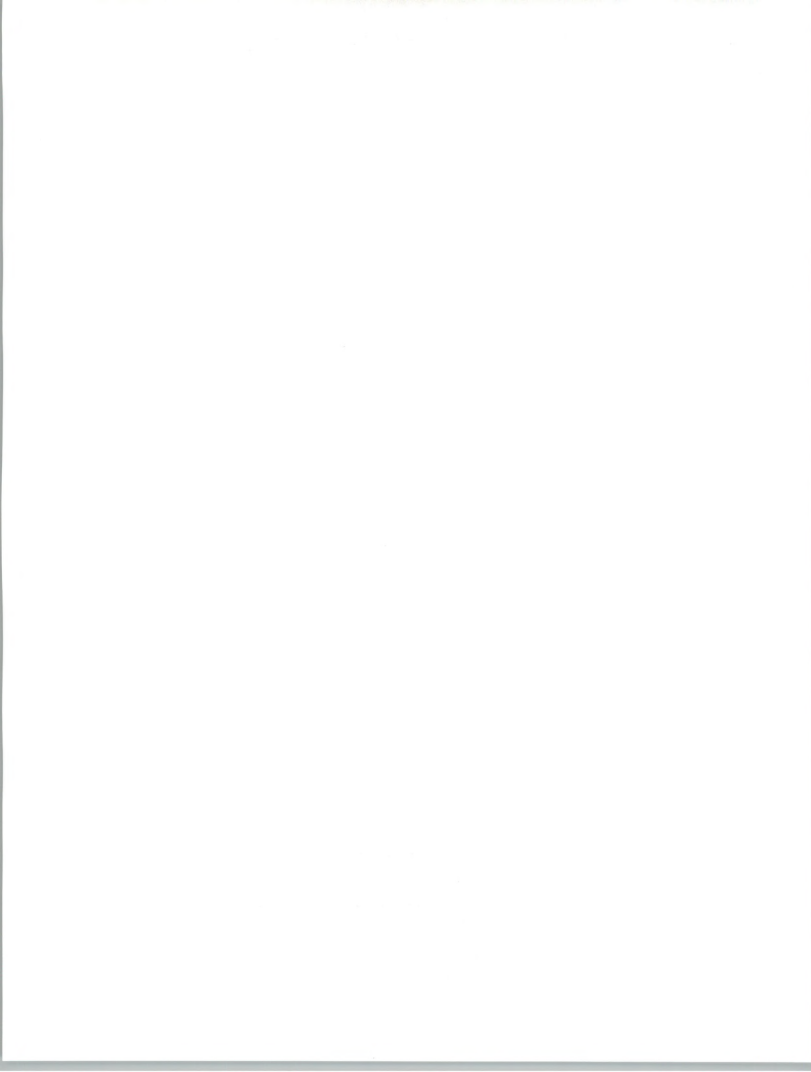

D**EDI and Other Data
Communication
Applications**

For the purposes of market definition, analysis and discussion, EDI should not be confused with other closely related data communication applications.

On-Line Systems

On-line systems, such as computer reservation systems (CRSs) and customer order-entry systems, are not considered EDI. These systems adhere to a terminal-host architecture, not a host-host architecture which is mandatory for the application to be considered EDI.

Electronic Funds Transfer (EFT)

Buying and selling relationships involve inquiring, ordering, bidding, shipping, and similar activities. The process culminates with a monetary exchange.

EDI is typically associated with the transfer of information regarding the first set of functions, and EFT is the transfer of monetary value.

Financial institutions have developed structured, computer processable data formats by which they can transfer value among themselves and on behalf of their customers. As these formats were developed within the banking industry (and are under the control of the Federal Reserve), EFT is not considered wholly an EDI application.

In particular, data exchanges involved in automated teller machine, point-of-sale, and many kinds of interbank transfers (such as those for foreign exchange trades, cash concentrations or direct deposit of payroll) are considered outside the definition of EDI. Only those funds/data transfers that are specifically linked to a corporate-to-corporate business transaction are considered within the scope of EDI. Often, industry insiders call the funds transfer side of EDI "EDI/EFT" or "Financial EDI."

Electronic Mail

Electronic mail contains text that is freely formatted/structured and therefore not machine processable. Although allied to EDI, E-mail is not considered EDI and will not be analyzed in this report.

E**The Role of
Value-Added
Networks**

Using today's standard (voice) telephone lines, the computer systems of a company can directly dial up another company's computers to exchange EDI messages. Many large companies, indeed, maintain their own substantial internal data communication networks and allow outside companies to dial into their networks. Today some EDI is done directly between companies using telephone lines in this manner. However, this is not practical for the majority of companies that are using or could potentially use EDI.

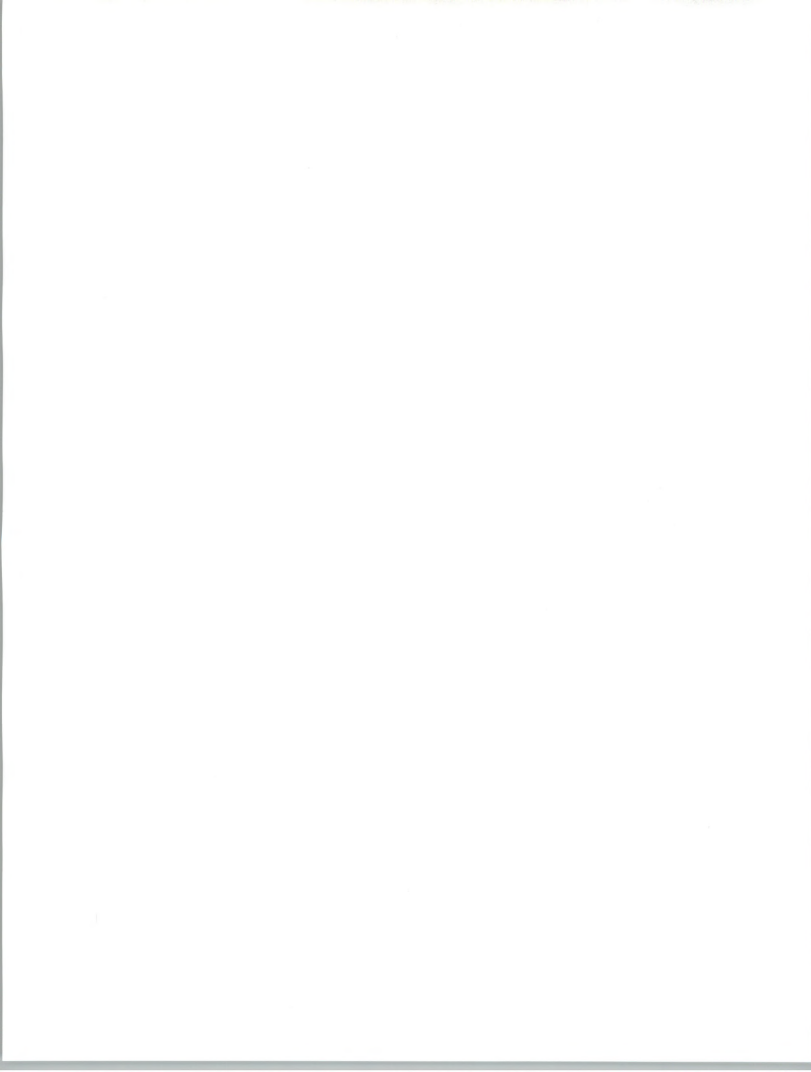

- The computers, communication protocols to connect them, and the data formats between sending and receiving computers may be incompatible.
- Business relationships are numerous and complex, especially for large companies. Each EDI trading partner may have unique data formatting, protocol, scheduling, and other requirements. Managing the multitude of specific requirements quickly becomes a significant task (requiring people and computing resources) when many (twenty or more) EDI trading partners come on-line.
- Direct links require expensive hardware at the host company. Multiple telecommunication ports, 24-hour continuous operation capability, fault-tolerant architecture, network management capabilities, mailboxing capabilities, the ability to handle a variety of protocols and line speeds, and security features are mandatory.

Because of these difficulties, the need arises for a third party, such as a value-added network (VAN) or a remote computer service bureau (RCS), to act as an intermediary between companies that trade electronically.

In addition to resolving the above-mentioned shortcomings of direct telecommunications between companies, third-party VANs provide other services to EDI-using companies. Exhibit III-3 lists the benefits of using a third-party VAN or RCS.

Today, networking for EDI transmissions is provided in three general variations:

- Directly between two companies using standard telephone lines.
- Via a third-party VAN/RCS, store-and-forward switch.
- Via an industry association clearinghouse, which is similar to a VAN/RCS. Transnet (automotive parts), IVANS (insurance), and Specification 2000 (aircraft parts and services) are examples of this approach.

EXHIBIT III-3

Benefits of a Third-Party VAN/RCS

- Store-and-forward mailboxing, to accommodate differing schedules of trading companies
- System integration/connectivity, to allow different computer systems to communicate with each other
- Aid in bringing up new EDI trading partners
- Reliability and large resources
- Security
- Tracking and control reporting
- Network management
- Easy access to many companies to trade with
- Data format conversion and translation

F**The Role of Software**

Essential to EDI is the translation of company data formats into standard formats or into the proprietary formats of a leading trading partner.

Users subscribing to VAN or RCS services may rely on software hosted on the vendor's processors to perform data format translations.

Alternatively, users may conduct this translation function on their own premises using in-house translation software. This approach is less expensive over time and is the dominant trend.

Users can write their own EDI translation software or purchase it.

- If purchased, customization and interfacing to internal applications by the software vendor, a professional service vendor, a consultant, or the user's own development staff is usually required.



- EDI software should be closely linked ("mapped") to existing applications to optimize its usefulness. Otherwise, a company may print out received EDI transactions and rekey the data, losing efficiency.

G

User Trends in Adopting EDI

1. Reasons for Implementing

Typically, it is the large Fortune 1000 companies that consider EDI a strategic technology and deliberately incorporate it into long-range plans. Smaller companies do not view EDI as strategic, and frequently implement it only because their largest customer has requested them to do so. In a 1989 INPUT survey, 63% of the companies said that they implemented EDI because their most important customer requested it. Only 33% said they implemented EDI for its strategic advantages.

2. The "Hub and Spoke" Phenomenon

Because most users adopt EDI at the request of a large trading partner, a "hub-and-spoke" pattern has emerged. A single large company—the hub—has electronic ties with several suppliers and trading partners—the spokes. EDI very typically grows along the lines of these hub-and-spoke clusters.

3. Customer Premise Data Format Translation

Since the mid-1980s, users have increasingly opted to perform data format translation on their own hardware platforms with purchased or developed software and not use the translation function of the VANs. An explosive increase in the number of third-party software vendors (there are now more than 40) since 1985 has led to a large selection of translation software. Packages are available not only for mainframes, but micros and midrange computers as well. Prices range from \$600 to \$20,000 for these non-mainframe packages and \$15,000 to \$115,000 for mainframe packages. Thus, there are multiple points of entry for the novice EDI company.

4. User Platforms

In the hub-and-spoke situation, the large hub company usually implements a mainframe translation software package. Its trading partner "spoke" companies usually implement micro or midrange packages. Sometimes, however, a large company will use a smaller platform than a mainframe—often a micro—to perform all communications with the VAN and all data format translation. The smaller platform is connected to the company's mainframe(s) where the applications reside. Such a configuration (called a "front-end") also provides a level of security by keeping outside telecommunications from directly interacting with the company's central processor.



5. Use of Networks

Method—INPUT's research shows that the majority (64%) of EDI users are using third-party networks. Very few (8%) telecommunicate directly with trading partners (using ordinary telephone lines). However, nearly 30% use both direct and third-party services and this "combination" group is expected to expand in proportion to the others.

Dual sourcing—INPUT's research shows that 24% of the surveyed sample uses more than one third-party network. Multiple networks are used to reach the greatest number of trading partners.

Internetworking services—The main EDI networks today are interconnected and will hand off a customer's EDI messages to other networks for delivery. Nearly 44% of EDI users are using this service.

6. Relationships with Trading Partners

EDI is often implemented along with just-in-time (manufacturing) or quick-response (retail) inventory programs. JIT and QR are inventory management concepts designed to minimize inventory levels. Only enough vendor products are ordered to meet the demands of production or customer sales.

In addition to minimizing on-hand inventories, JIT and QR programs often minimize the total number of suppliers a company does business with. Companies seek only those suppliers who competently meet delivery dates and quality levels. Thus, EDI is often conducted among companies that have formed a very close business relationship.

7. EDI Use Grows in Two Dimensions

Typically, a pilot EDI program starts with a single transaction set (for example, a purchase order), with a single trading partner. After the pilot—which may take anywhere from one week to three months—more trading partners are brought in using the same transaction set. Once a certain volume of trade is conducted in a single transaction set, a new transaction set is introduced and the process is repeated. First the number of trading partners increases, then the number of transaction sets.

8. Parallel Paper and Electronic Systems

No company yet transacts all business in EDI (automobile manufacturers may be the first companies to do so). Even advanced EDI-using companies use EDI in small proportions of its potential use. Typically, a company only sends EDI purchase orders to a handful of key suppliers. INPUT's survey of large Fortune 500 corporations (corporations with



billions in revenues) found that the average number of EDI relationships was only 110—despite these large companies having thousands of trading partners.

EDI-using companies have discovered an “80-20” rule in implementing EDI. The top 20% of their trading partners are responsible for 80% of their business. Therefore, a company will target these key partners to start an EDI program. For the remaining 80% of their trading partners (with whom the company transacts only 20% of its business), traditional paper documents are used. Thus, all companies conducting EDI today have two parallel systems: EDI and paper.

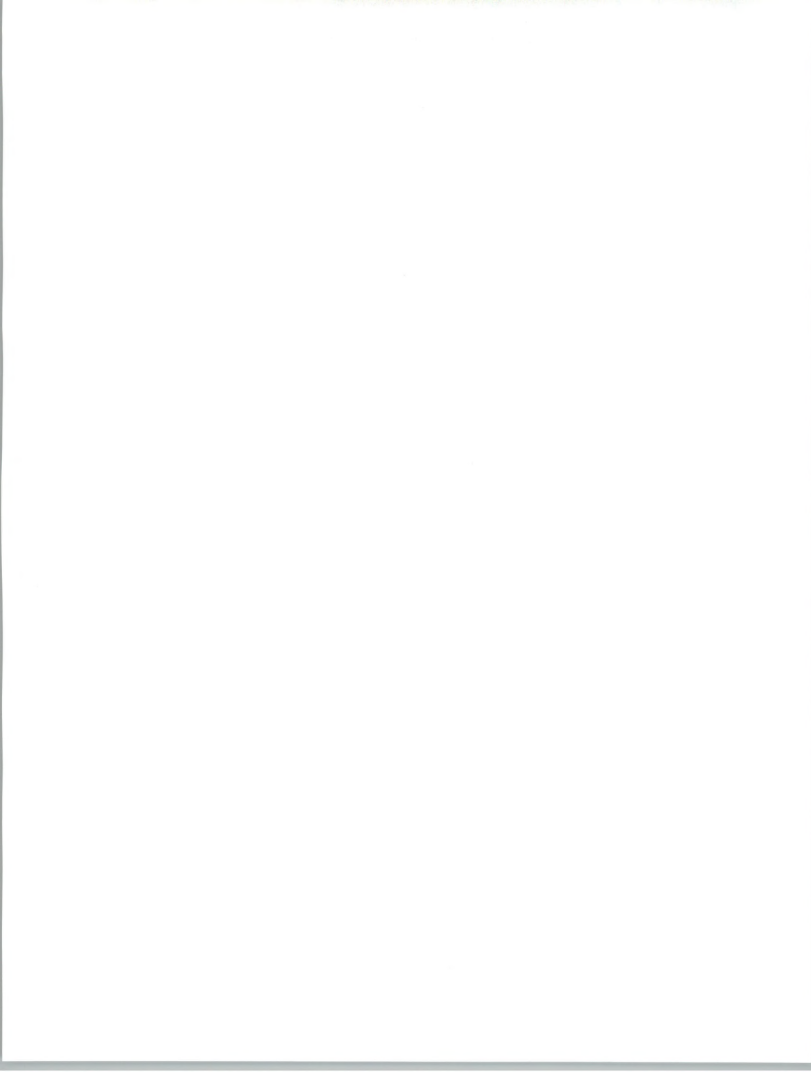

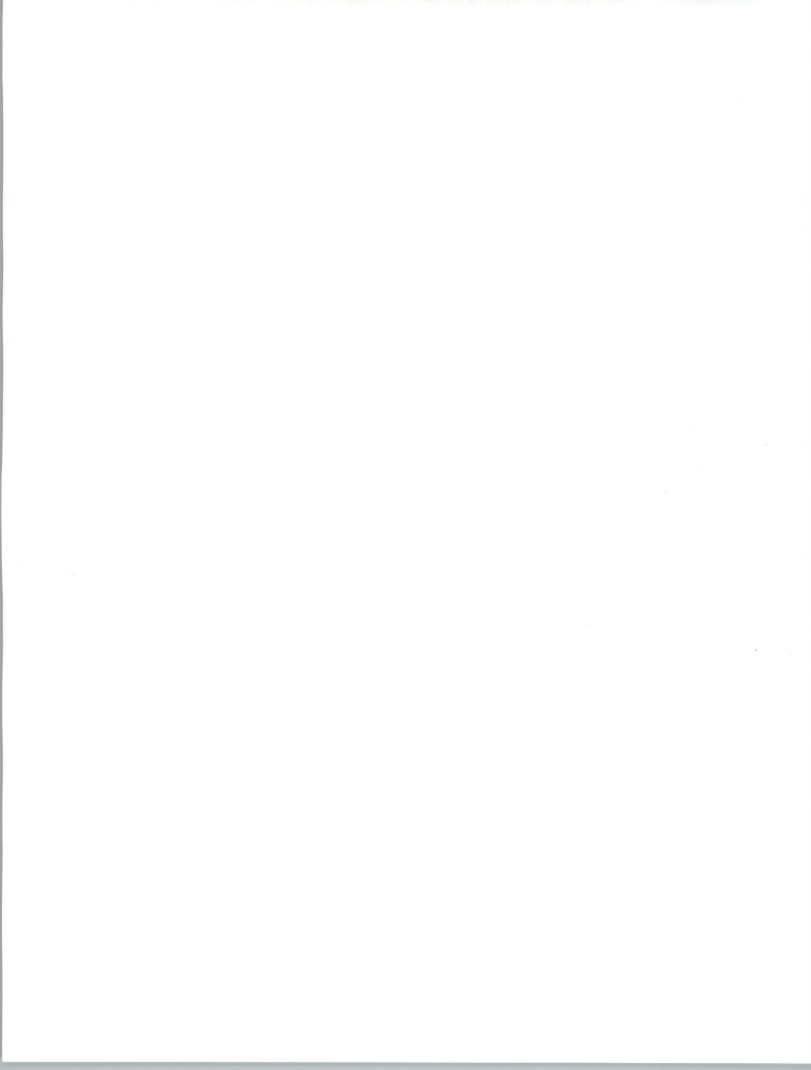



EDI Input-Output Analysis



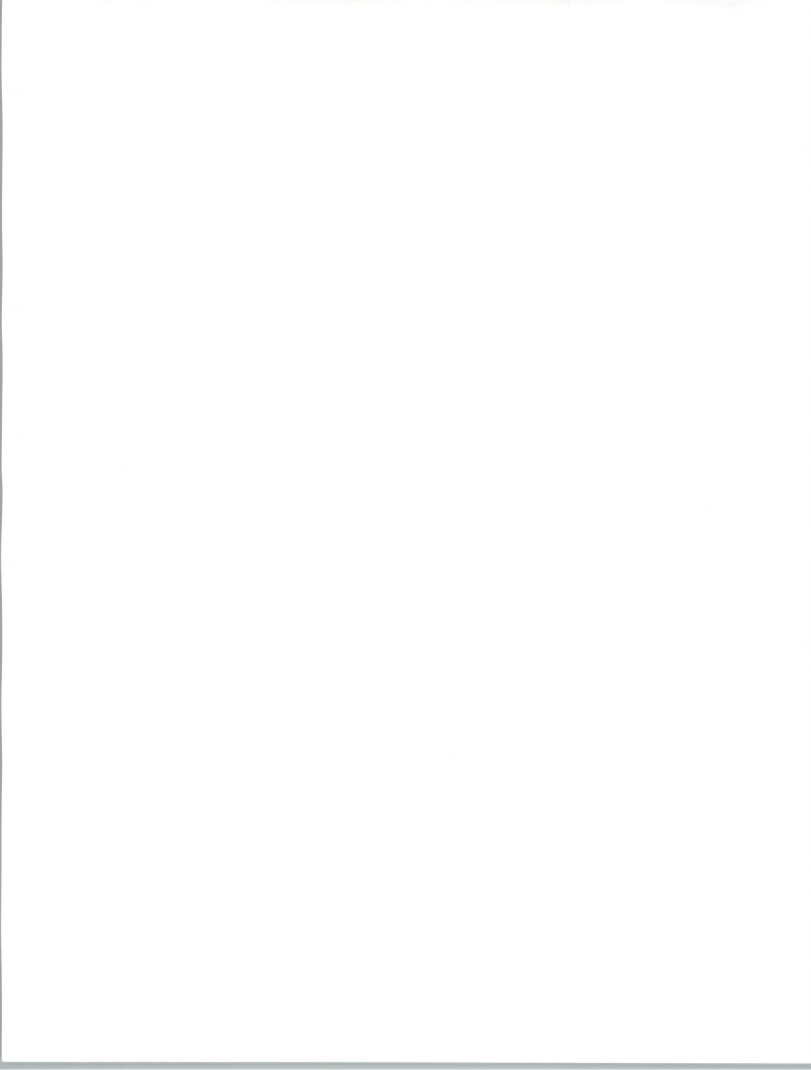



EDI Input-Output Analysis

In this chapter, INPUT introduces an analytical framework that helps the observer distinguish where and how EDI is used in the economy.

Called the EDI Input-Output Matrix, the framework depicts the trade flows between industry sectors and specifically, the EDI applications that support these flows.

A

Definition

Input-output analysis was invented by the economist Wassily Leontieff, who won a Nobel prize in 1973 for the invention.

It is a method of quantifying the mutual interrelationships among the various sectors of an economic system (the system being as diverse in scope as the world, a nation, or a metropolitan area).

The structure of each sector's production process is represented by a vector of structural coefficients that describe the relationship between the input it absorbs and the output it produces.

The technical structure of the entire system can accordingly be represented concisely by the matrix of technical input-output coefficients of all its sectors.

The horizontal rows of coefficients show how the output of each sector of the economy is distributed among the others. Conversely, the vertical columns show how each sector obtains from the others its needed input of goods and services. Since each figure in any horizontal row is also a figure in a vertical column, the output of each sector is shown to be an input in some other.

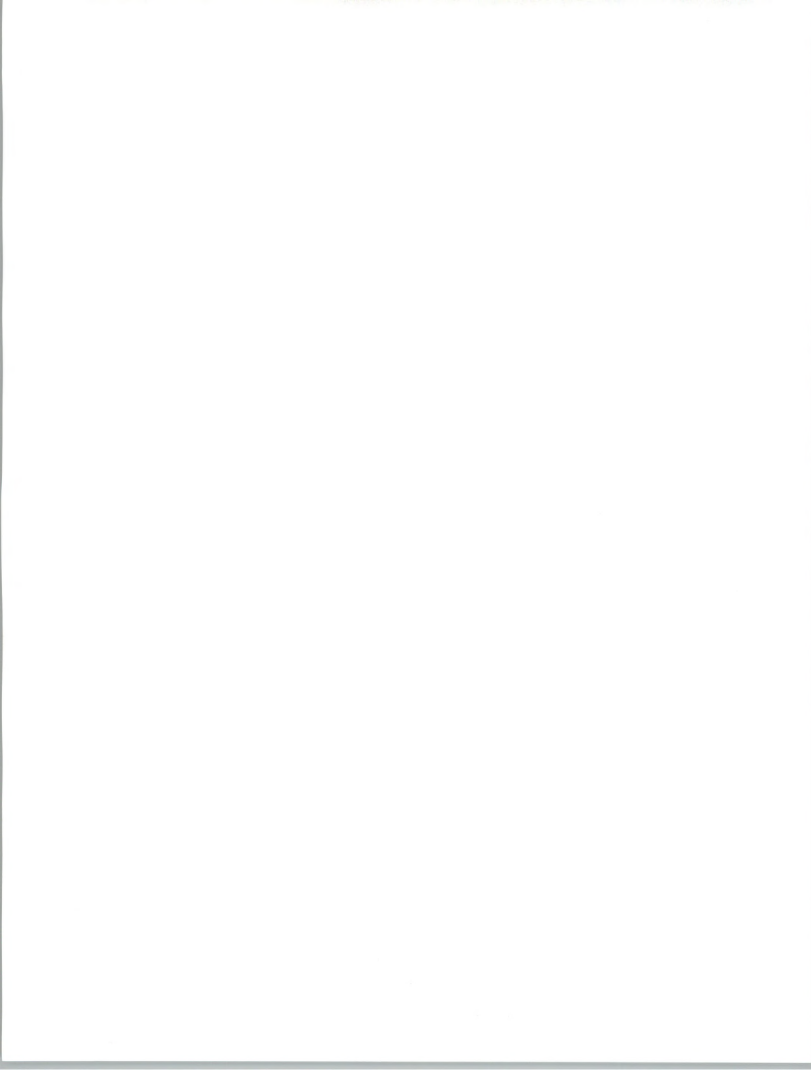

The input-output table thus reveals the fabric of an economy, woven together by the flow of trade which ultimately links each branch and industry to all others.

B

Relevance to EDI

By definition, EDI occurs between organizations and industries. It doesn't make sense to speak of EDI within a single organization or industry. EDI is a connecting/bridging application. EDI highlights the interconnections of organizations and industries.

EDI activity, therefore, correlates to intercompany, interindustry trade flows, the phenomena that the conventional input-output matrix measures. Input-output analysis is congruent with the nature of EDI.

Analyzing EDI requires looking at interrelated value chains and trading communities. For example, analyzing EDI only within the retail sector would miss the true value of EDI: the way it connects retailers with apparel manufacturers and, further up the chain, apparel manufacturers with textile mills. This entire multisector community is the appropriate unit of analysis.

In this report, INPUT presents an EDI Input-Output Matrix that locates EDI activity by application type for fourteen vertical markets of the U.S. economy.

Exhibit IV-1 shows EDI activity throughout these 14 vertical markets.

In addition, three vertical markets where EDI activity is most intensive (process manufacturing, discrete manufacturing, and distribution) are disaggregated into another Input-Output Matrix of industry subsectors for more detailed analysis.

Exhibit IV-2 shows this more detailed EDI Input-Output Matrix.

Unlike the traditional economic input-output matrix, the INPUT matrix shows EDI *applications* in matrix cells, not dollar values. A variety of data can be placed within the cells, as will be discussed below.

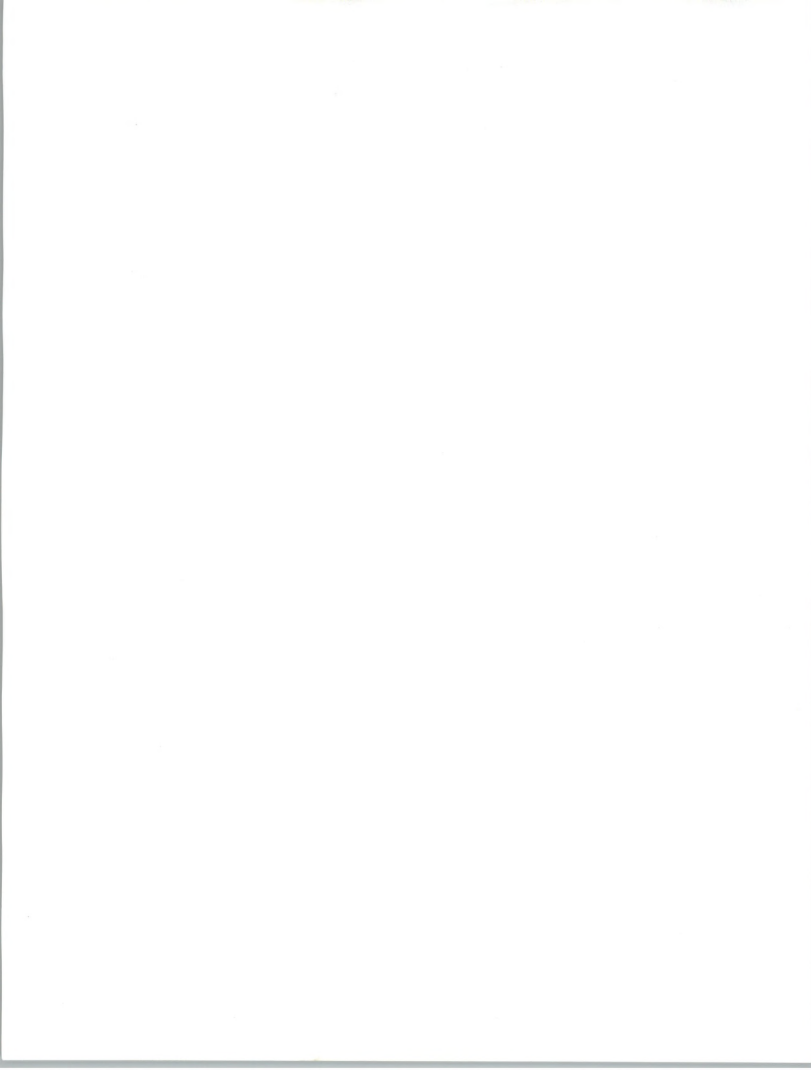

INDUSTRIES AS SELLERS



INDUSTRIES AS BUYERS →

	Discrete Manufacturing	Process Manufacturing	Distribution	Transportation	Utilities	Communications
Discrete Manufacturing				• Spec 2000 • Transnet	• Electrical equipment	
Process Manufacturing	See Expanded Matrix			• Spec 2000 (fuels)	• Fuels	
Distribution (Retail/Wholesale)						
Transportation	(High)	(High)	(High)	• Intermodal handoffs • RR handoffs • CLMs	(Infancy)	• Film distribution
Utilities			Franchise site power billing	RR crossing billing		• Billboard power billing
Communications	Phone billing	(all Industries) →				• Film dist. data between theaters & distributors
Banking (Financial EDI Services)	• GM pays suppliers • Lock box • Cash mgmnt. • EFT pymnt svc	(all Industries) →	• Factoring svcs • Gas stations pay oil co.s • Retailers pay apparel maker	• Freight bill processing		
Insurance						
Government	• EFT for corp. taxes	(all Industries) →		• Customs • EPA		
Agriculture			• Farm co-ops • Dairies			
Construction		• Petrochemical, food processing, paper, pharmaceutical co.s buy construction services and facilities			• Utilities co.s buy new construction & renovation for facilities	
Education						
Health care						
Services				• Freight forwarding • Customs brokering		

Front / page 27

copy @ 98% onto 11x17

Trim $\frac{1}{2}$ " to $\frac{3}{4}$ " off RIGHT
END. Velobind punch
LEFT SIDE.

Fold less than $\frac{1}{2}$



OUTPUT MATRIX

Cells contain: • Significant EDI projects • Dominant uses of EDI
 • The degree of EDI standards development (low, medium, high)

Ranking	Insurance	Government	Agriculture	Construction	Education	Health care	Services
		<ul style="list-style-type: none"> • CALS • Vendor Express • GSA 		(Infancy) <ul style="list-style-type: none"> • Fittings, valves, parts, electrical supplies 	<ul style="list-style-type: none"> • Book buying (Pubnet) 	<ul style="list-style-type: none"> • Medical/surgical supplies 	
		<ul style="list-style-type: none"> • USMC commissaries • GSA 	<ul style="list-style-type: none"> • Fertilizers 			<ul style="list-style-type: none"> • Pharmaceutical supplies 	
			(Infancy) <ul style="list-style-type: none"> • Invoice prcssng • No purchase order potential 	<ul style="list-style-type: none"> • Contractors buy materials and tools 			
		<ul style="list-style-type: none"> • USMC transport program 					<ul style="list-style-type: none"> • Travel agents buy airline services
	<ul style="list-style-type: none"> • NEIC • IVANS 						
		<ul style="list-style-type: none"> • US military buys lrg. scale construction services 		<ul style="list-style-type: none"> • Contractor-designer-subcontractor EDI 			<ul style="list-style-type: none"> • Commercial real estate developer buy office bldg. construction
		<ul style="list-style-type: none"> • Student loan information • Veterans Administration 			<ul style="list-style-type: none"> • Transcripts • College catalogs • Standardized test data 		
	<ul style="list-style-type: none"> • Health care providers submit health claims 						
							<ul style="list-style-type: none"> • Travel, tourism

the 1990s, the number of people in the UK who are aged 65 and over has increased from 10.5 million to 13.5 million, and the number of people aged 75 and over has increased from 4.5 million to 6.5 million (Office of National Statistics 2000).

There is a growing awareness of the need to address the needs of older people, and the need to ensure that the health care system is able to meet the needs of this population. The Department of Health (2000) has identified the need to improve the health care system for older people, and has set out a number of key objectives for the health care system to meet the needs of older people.

The Department of Health (2000) has identified the need to improve the health care system for older people, and has set out a number of key objectives for the health care system to meet the needs of older people. The objectives are to improve the health care system for older people, and to ensure that the health care system is able to meet the needs of this population.

The Department of Health (2000) has identified the need to improve the health care system for older people, and has set out a number of key objectives for the health care system to meet the needs of older people. The objectives are to improve the health care system for older people, and to ensure that the health care system is able to meet the needs of this population.

The Department of Health (2000) has identified the need to improve the health care system for older people, and has set out a number of key objectives for the health care system to meet the needs of older people. The objectives are to improve the health care system for older people, and to ensure that the health care system is able to meet the needs of this population.

The Department of Health (2000) has identified the need to improve the health care system for older people, and has set out a number of key objectives for the health care system to meet the needs of older people. The objectives are to improve the health care system for older people, and to ensure that the health care system is able to meet the needs of this population.

The Department of Health (2000) has identified the need to improve the health care system for older people, and has set out a number of key objectives for the health care system to meet the needs of older people. The objectives are to improve the health care system for older people, and to ensure that the health care system is able to meet the needs of this population.

The Department of Health (2000) has identified the need to improve the health care system for older people, and has set out a number of key objectives for the health care system to meet the needs of older people. The objectives are to improve the health care system for older people, and to ensure that the health care system is able to meet the needs of this population.

The Department of Health (2000) has identified the need to improve the health care system for older people, and has set out a number of key objectives for the health care system to meet the needs of older people. The objectives are to improve the health care system for older people, and to ensure that the health care system is able to meet the needs of this population.

11 x 17 fold out here



		BUYERS →												
		Discrete Manufacturing	Autos, auto parts	Apparel, accessories	Electronics, electrical, computer	Aerospace	Hard goods	Office products	Medical/surgical supplies	Printing, publishing	Process Mfg.	Petroleum	Grocery	Textile
SELLERS ↓	Autos, auto parts	■												
	Apparel, accessories		■											
	Electronics, electrical, computer			■	■									
	Aerospace				■									
	Hard goods					■								
	Office products					■								
	Medical/surgical supplies													
	Printing, publishing													
	Process Manufacturing													
	Petroleum											■		
Grocery														
Textile			■										■	
Chemical	■					■					■	■	■	
Steel	■				■	■							■	
Paper/wood						■			■	■			■	
Pharmaceuticals														
Tobacco														
Distribution														
Genl. merch.														
Grocery														
Hardware														
Auto parts														
Gas stations														
Bookstores														
Eating, drinking establishments														
Drug stores														

Back/page 28

probably

copy @ 95%

(Manufacturing And Distribution)

Legend:

- EDI already established
- ▨ High EDI potential
- Negligible if any EDI

Chemical Steel Paper/wood Pharmaceuticals Tobacco Distribution Genl. merch. Grocery Hardware Auto parts Gas stations Bookstores Eating, drinking establishments Drug stores

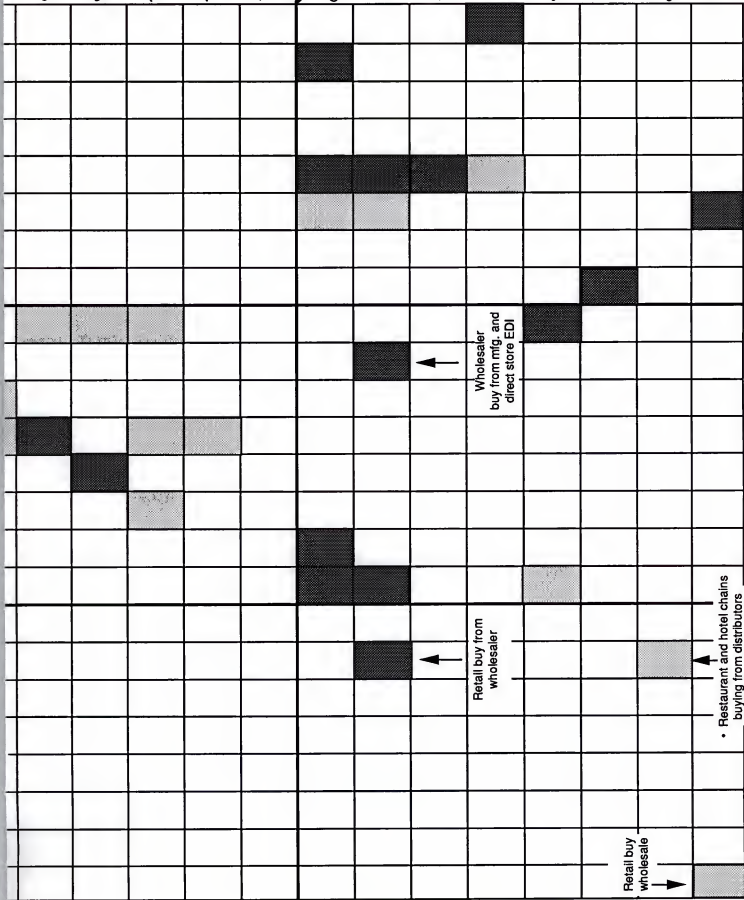

Wholesaler buy from mfg. and direct store EDI

Retail buy from wholesaler

Retail buy wholesale

- Restaurant and hotel chains buying from distributors
- Vending machine operations

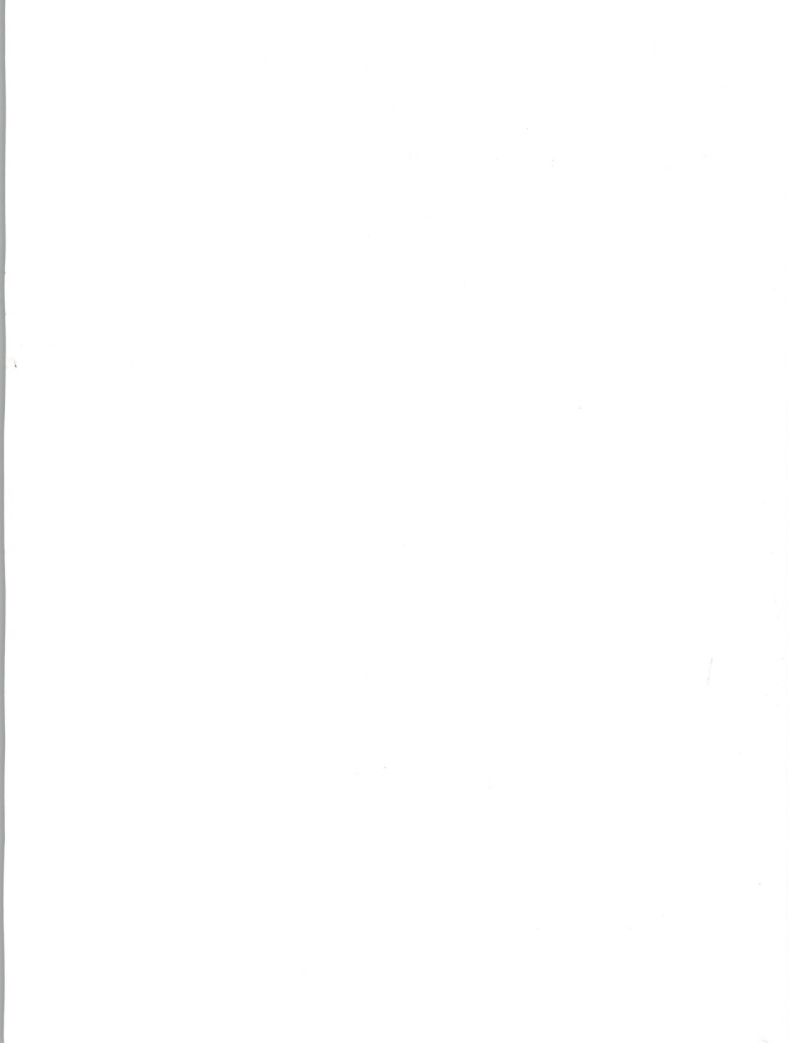

C**How to Read the EDI Input-Output Matrix**

The EDI Input-Output Matrix maps transactions occurring within and among industry sectors.

For a given sector, the matrix shows who its supplier trading partners are and who its customer trading partners are. For each sector-to-sector exchange point, an EDI application(s) is listed if one exists.

To identify the sector's supplier trading partners, select the industry sector along the top/horizontal axis. Reading down the column reveals the EDI applications with suppliers.

To identify the sector's customer trading partners, select the industry sector along the left-side/vertical axis. Reading across the row reveals the EDI applications with customers.

Exhibit IV-3 displays the rule for reading the EDI Input-Output Matrix.

EXHIBIT IV-3

How to Read the EDI Input-Output Matrix

- Read down columns to see a sector's suppliers
- Read across rows to see a sector's customers

For example, reading down the column under Utilities shows that utility companies use EDI to purchase electrical equipment from the discrete manufacturing sector (electrical equipment manufacturers) and fuels from the process manufacturing sector (the petroleum industry). Utilities have just begun to use EDI to buy transportation from the pipeline companies and construction services from the construction industry.

Reading across the row beside Utilities shows that utilities use EDI to bill customers in the distribution sector (chain restaurants with multiple power meters), transportation sector (railroads with RR crossings, each with their own power meter), and the communications sector (owners of billboards, each billboard with its own power meter).

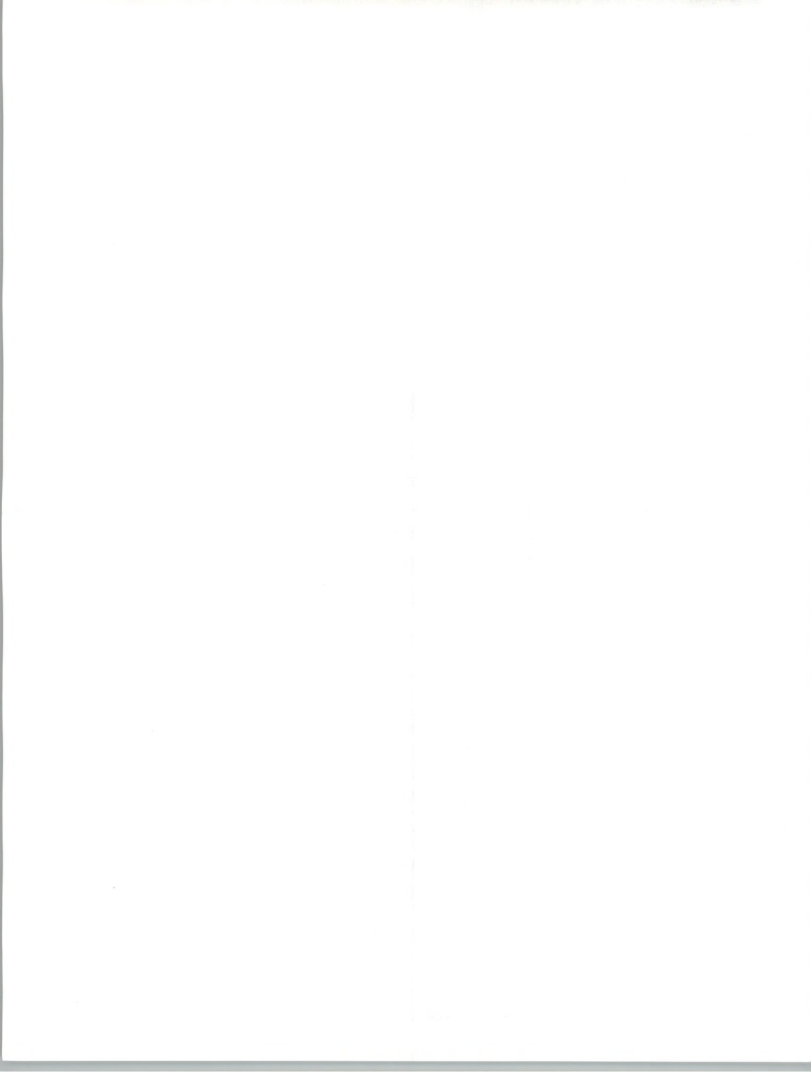

D**Uses of the
Input-Output Matrix****1. General**

The EDI Input-Output Matrix is useful to both vendors and users of EDI products and services because it locates, in one easily read chart, where all EDI activity is taking place. This snapshot feature helps to plan for EDI systems.

2. Users

Specific benefits of the Input-Output Matrix to users include the following:

- Helps users identify trading partners who are EDI capable
- Helps users identify applications most likely used by trading partners (purchase orders, invoices, ship notices, freight bills, customs declarations)
- Helps users analyze entire trading community/supply chain for opportunities/possibilities for optimized coordination through community-wide/supply-chain-wide EDI-based applications. Community-wide applications include the sharing of point-of-sale and inventory data with suppliers and customers once or twice removed in the supply chain, implementing community-wide/supply-chain-wide just-in-time relationships, and establishing community-wide EDI data base applications. One community that is doing all three is the retail/apparel/textile value chain.
- Helps users identify potential outsourcing and company restructuring options. Certain divisions or operations of a company may best be performed by a separate entity (for example, computer operations, fulfillment operations, specialized manufacturing processing, professional services, work provided by temporary personnel, work provided by telecommuting staff). Conversely, certain operations may be better done in-house. The EDI matrix, because it compartmentalizes the value chain in discrete units, helps a firm chart its organizational boundaries. It can acquire or divest divisions or operations based on whether they are "EDI plug-compatible" or not.

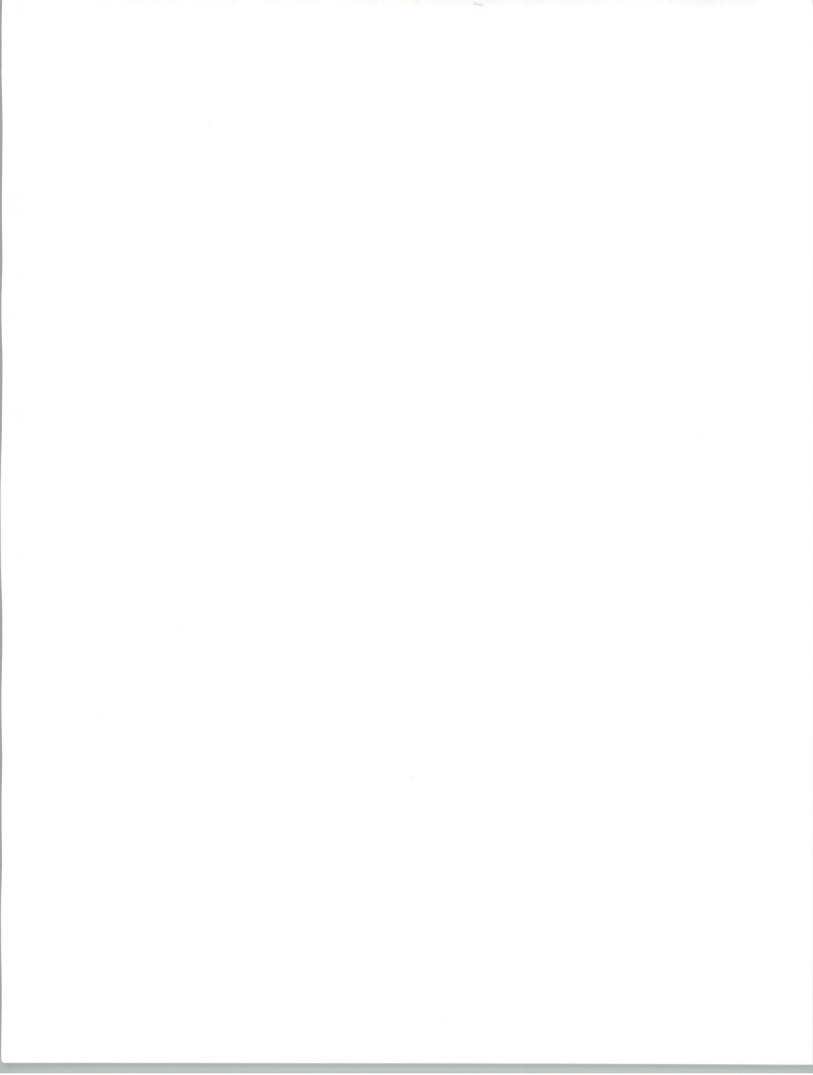

3. Vendors

a. General

For all vendors to the EDI market, the matrix helps to:

- Identify EDI activity (immediate market opportunities)
- Identify those sectors and intersector interfaces where EDI could be implemented (market potentials)
- Identify application types per sector and per intersector interface to further fine-tune products and services to meet customer needs
- Estimate user expenditures per sector and sector interface
- Map out market share/competitor penetration per sector and sector interface

b. Network Service Providers

Network service providers may find the EDI Input-Output Matrix the most useful because it illustrates the web of interconnections among sectors that networks tangibly provide with telecommunication linkages.

In addition to those already cited, other uses of the matrix to network providers are to:

- Allow network providers to insert transaction flow estimates in each sector interface cell and to thereby accurately estimate market size
- Permit network providers to identify contiguous market sectors that will complement their customer base. Successful networks have targeted specific industries and trading communities (see Conclusion, Recommendations). The matrix helps identify communities where a network can leverage its marketing efforts.

c. Software and Professional Services

For providers of EDI software and consulting services, the matrix helps identify EDI application areas so that vendors can match products and expertise to specific customer needs.

Application software vendors may find this benefit to be the most useful. The matrix allows them to see the broader software application context in which EDI is being used. When the software house knows what kind of transaction set is being sent (purchase orders, invoices, ship notices,

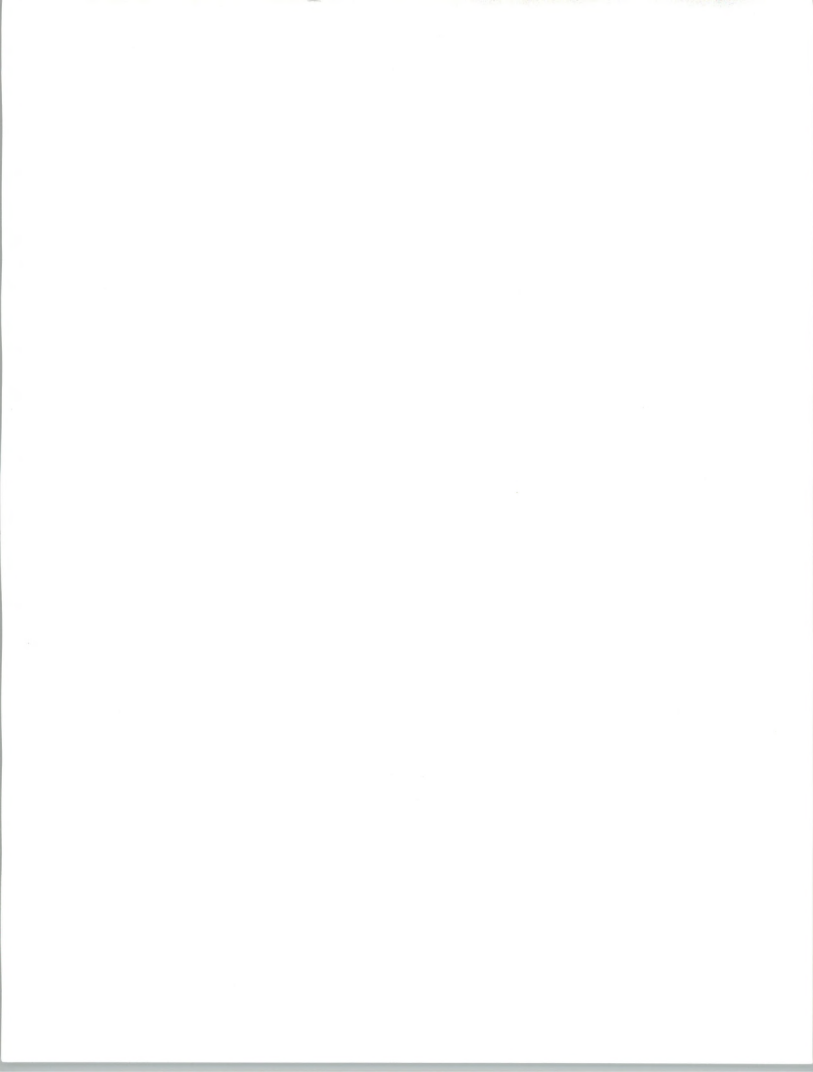

material safety data sheets, waybills, car location messages, product quality data, inventory advices, point-of-sale data, payment remittances, etc.), it can build EDI interfaces into the appropriate application.

4. Varieties of Data in the Cells

The EDI Input-Output Matrix can act as a base tool for inserting many kinds of data in the cells. The cells can be filled in with:

- EDI applications (as shown)
- EDI standards families in use
- EDI usage intensity indicated by shading (as shown)
- Leading vendors for a given sector/intersector interface
- EDI transaction volumes, either EDI document counts or kilocharacter counts per intersector interface
- All media transaction volumes, such as counts of all transactions of all media (EDI, fax, paper, phone) needed to enact trade between sectors. This would give a picture of EDI potential.
- Dollar-value estimates for inter-industry trade flows (as the traditional input-output matrix shows). Such data for the U.S. economy is available from the Bureau of Economic Analysis, U.S. Department of Commerce. For the world economy, Japan's Ministry of International Trade and Industry (MITI) is compiling an input-output matrix. Some European countries have developed I/O matrices for their domestic economies.
- Transactions-per-dollar-value. This would indicate how many transactions it takes to enact the trade flow between sectors. This data could be obtained by correlating transaction volumes with trade flow monetary values.

E

Implications of Input-Output Analysis

The EDI Input-Output Matrix underscores the possibilities for the assembling, disassembling and reassembling of value chains via information-communication technologies. These business and industry organization issues, along with others, are discussed in the INPUT report, *EDI: Business Integration Issues*.





Market Size and Forecast

Vertical line separator

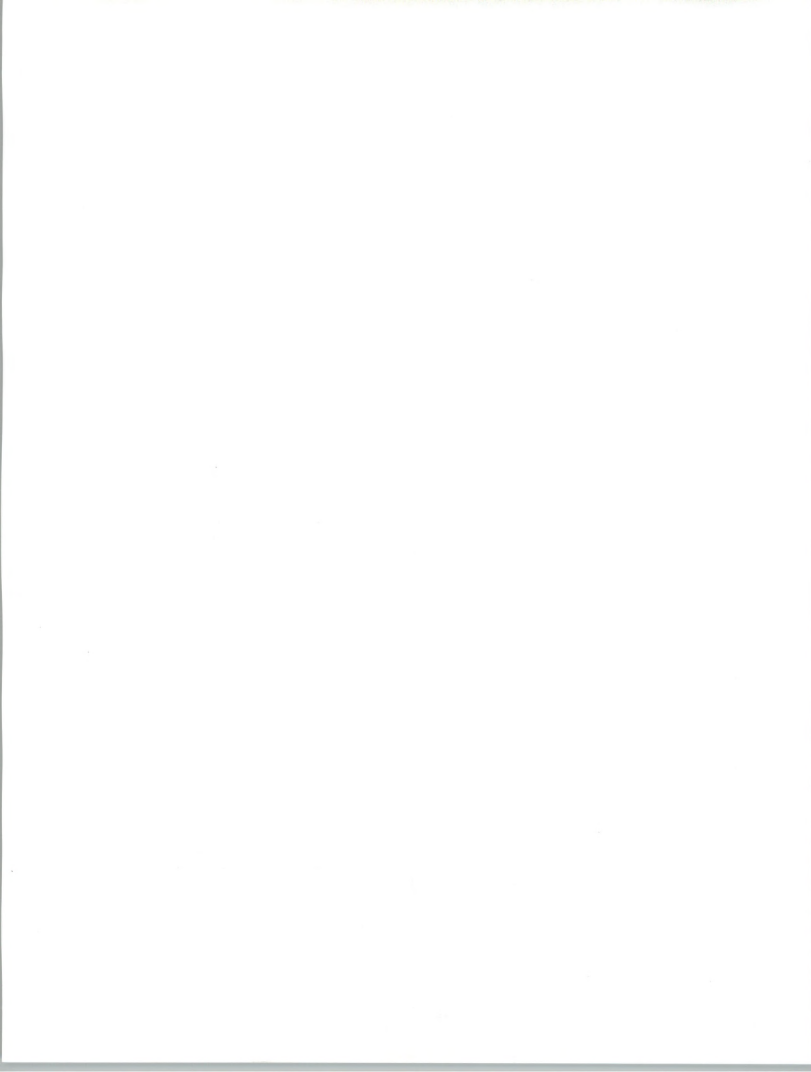



Market Size and Forecast

A

Introduction

This chapter presents quantitative data on the market for EDI software, network services, and professional services.

The market is estimated in terms of numbers of EDI-using companies and expenditures on EDI products and services by these companies.

B

Challenges of Measuring the EDI Market

The following are some of the challenges faced in trying to estimate the EDI market:

- Not everyone uses the same definition of EDI.
- Most interviewees at a user or vendor company will be unable to answer all questions relevant to a market research study.
- Double counting. One cannot add up all trading partners of every EDI user (or all the customers of every network) to find the total number of EDI users. Many of one company's EDI trading partners are also the EDI trading partners of another company.

1. Counting the EDI Marketplace

Exhibit V-1 lists the possible variables that would characterize EDI usage.

This report focuses on the number of companies using EDI, the number of trading relationships, the total expenditures of users, and the total revenues of vendors.



Statistical Quantities that Characterize EDI Usage

- Number of companies using EDI
- Number of locations using EDI (some companies have more than one location using EDI)
- Number of EDI mailboxes on networks
- Number of invoicable EDI customers on networks (some companies' EDI network fees are paid for by a trading partner)
- Number of EDI transaction sets sent
- Number of EDI digital characters sent
- Dollar volume of trade that EDI is responsible for
- Percentage of total communication transactions (phone, mail, facsimile, E-mail, telex) that EDI is responsible for
- Number of EDI trading relationships (explained below)
- Total expenditures by users on EDI services and products
- Total revenues of vendors of EDI services and products

2. EDI Users versus EDI Trading Relationships

An important distinction in estimating EDI use is that between total EDI users and total EDI trading relationships.

Exhibit V-2 illustrates the difference between users and relationships.

EDI usage can grow without an increase in the number of users. The growth comes from existing users establishing new EDI trading relationships among themselves and/or existing users expanding their use of EDI with existing trading partners (introducing new transaction sets, increasing the volume of use of existing transaction sets, etc.).

[The page contains extremely faint and illegible text, likely bleed-through from the reverse side of the document. No specific content can be transcribed.]

EXHIBIT V-2

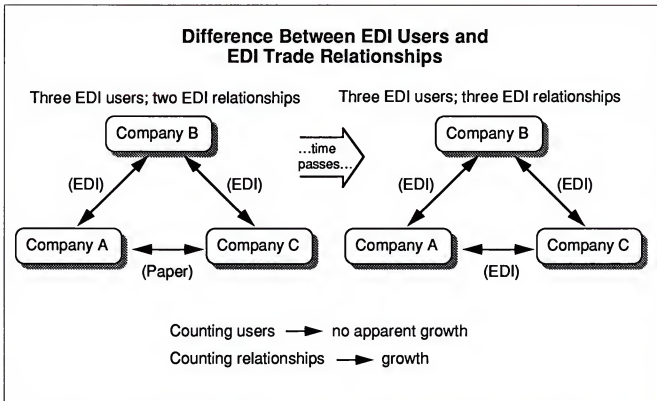

The relationship between the number of users and the number of trading partners is shown in Exhibit V-3.

The formula states that each new EDI user that joins the total user population adds to the existing number of potential trading relationships by its numeric ranking minus one. In other words, if it is the 75th EDI user, it brings 74 more trading relationships to the existing number of relationships.

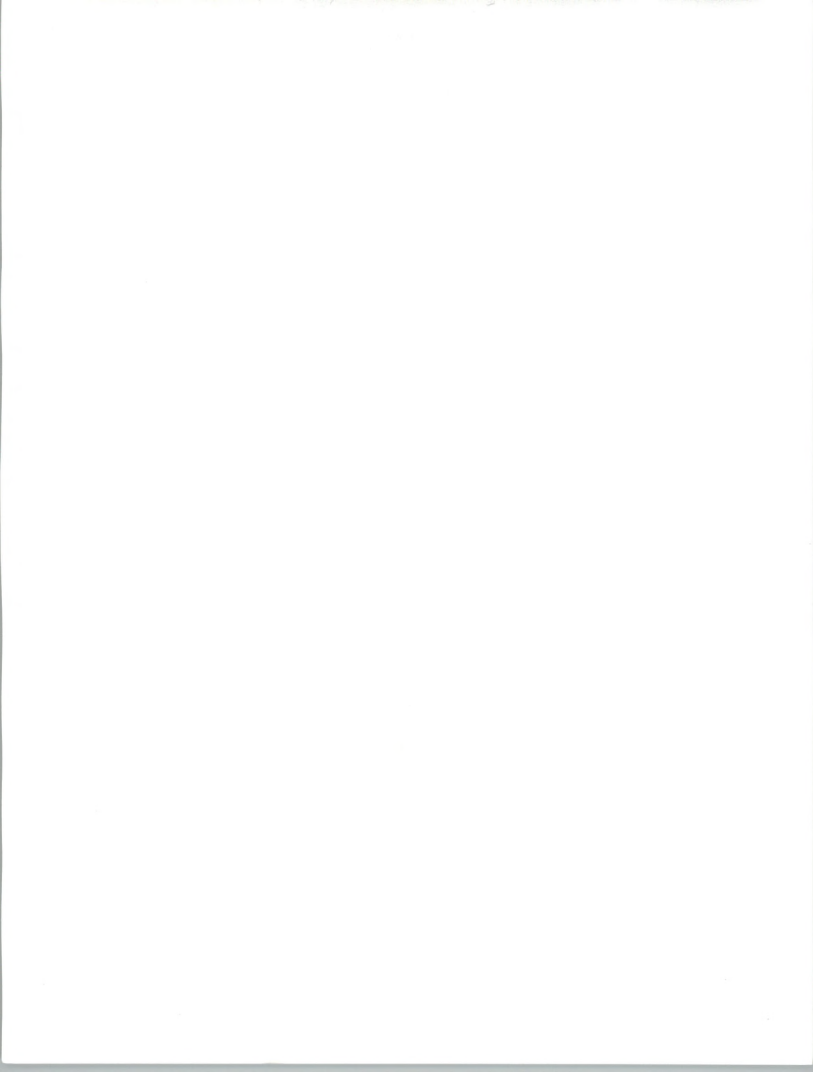

EXHIBIT V-3

Relationship between Total EDI User Population and Potential EDI Trading Relationships

$$\sum_{i=1, n-1} n-1 = i$$

n = total number of EDI-using companies

i = total number of EDI trading relationships

n	$n - 1$	$\Sigma n - 1$
2	1	1
3	2	3
4	3	6
5	4	10
.	.	.
.	.	.
.	.	.

Exhibit V-4 graphically depicts the relationship between users and trading relationships.

The implications of this relationship differ for the EDI software vendor and the network services provider.

Even when the growth in absolute number of EDI users slows down or ceases, service vendors will still enjoy growth in their business, while software vendors will experience a maturing market.

- Software vendors will be threatened when the growth of EDI adoption slows down. Their market is driven by new companies adopting EDI, and product turnover (companies changing software brands or upgrading).

THE UNIVERSITY OF CHICAGO
1100 EAST 58TH STREET
CHICAGO, ILLINOIS 60637

THE UNIVERSITY OF CHICAGO
1100 EAST 58TH STREET
CHICAGO, ILLINOIS 60637

EXHIBIT V-4

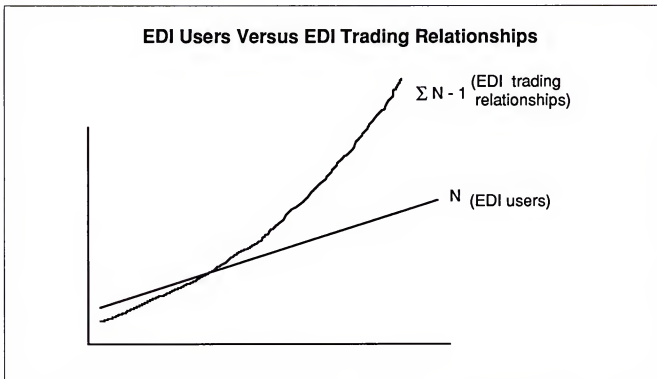

- Network vendors, however, can continue expanding their markets even when the total number of EDI users stabilizes. The market for network services is driven by new companies adopting EDI, new relationships between companies being established, growth in transmission volumes, and new network services.

INPUT expects the growth in absolute number of EDI-using companies to eventually level off. When this will happen is still unclear. A macro 80-20 rule may govern EDI proliferation in the economy: only the 20% of all companies and/or trading relationships that are responsible for 80% of the GNP will employ EDI.

C

Assumptions of the Forecast Model

The U.S. EDI market has been examined as the sum of its components as follows:

- Network services, including access point maintenance, error correction, protocol speed conversions, switching, store-and-forward services, internetworking through gateways, format compliance checking, format translations/conversions, and other processing services. These services are typically provided by third-party service providers' networks, although private networks may provide many of these elements. This market forecast estimates only third-party network services.

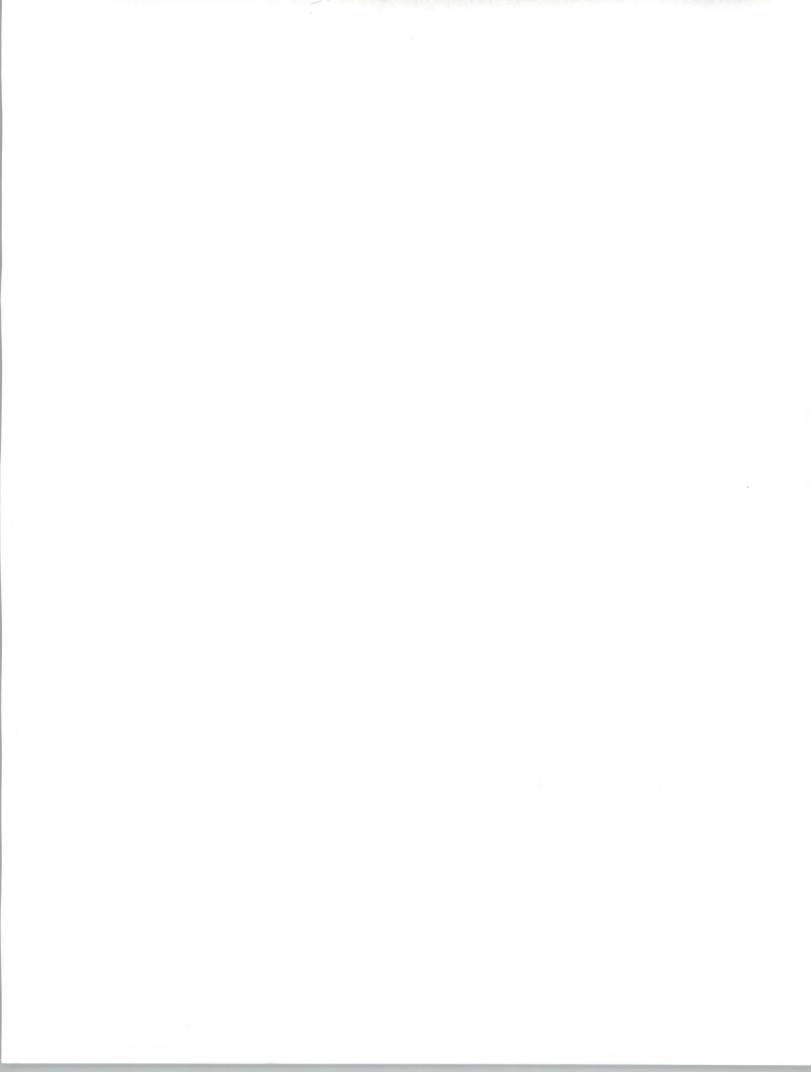

- Software that resides at user premises that translates data between EDI standard formats and formats of the company's internal software applications.
- Professional services for systems design, software customization, equipment selection and acquisition, systems integration, facilities management, and education and training.

The following are specific assumptions for each delivery mode.

1. Network Services

All revenue figures are derived from customer base information. The customer base was obtained from interviews of service providers, collateral documentation, and common-sense guessing. The customer base is the number of discrete companies using the network (not mailboxes on the network or invoiceable accounts). The data from user interviews showed that companies with 20 or more trading partners paid an average of \$18,000 per year in network charges. (After examining the data, INPUT discovered that 20 trading partners was the threshold that separated the steady, large EDI user from the experimental/beginning small user.) Checking with network providers, INPUT learned that 80% of the networks' EDI customers are spoke-type companies that pay a minimal amount per year in network charges. Thus, INPUT, in building a model for revenues for network service providers, assumes that 80% of a network's customers pay, on average, \$2,000 annually, 15% pay \$10,000 annually, and 5% pay \$18,000 annually. This formula was applied to the customer base of each EDI network.

Exhibit V-5 shows the distribution of customer revenues per percentile for EDI network providers.

These assumptions are applied to all U.S. EDI service providers. Of course, each network has its own specific model. The given assumptions are considered average. INPUT speculates that if the model errs, it errs on the low side—that is, the model underestimates the network market.

EDI service providers derive some revenue from professional services and software. These components are deliberately omitted from the given revenue estimates. The estimates are strictly for EDI data transmissions.

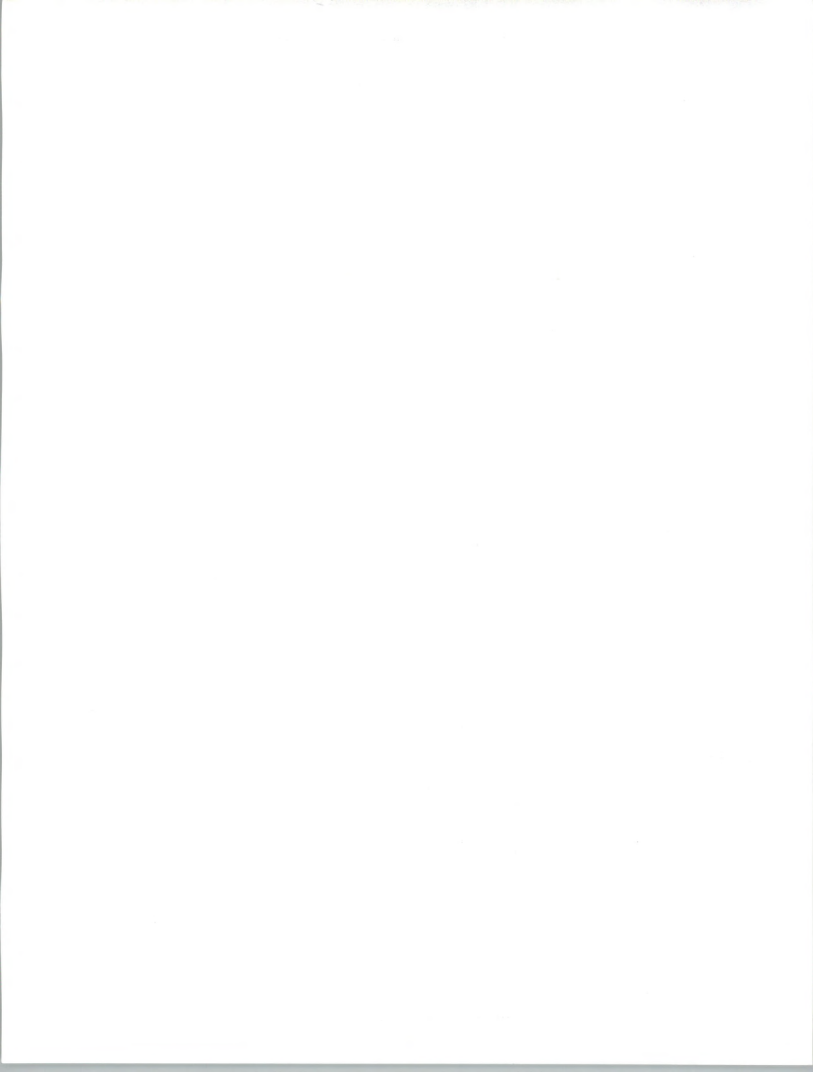

EXHIBIT V-5

Distribution of Customer Revenues by Percentile for EDI Network Services

Customer Base Percentile	Average Network Revenue
80%	\$2,000
15%	\$10,000
5%	\$18,000

Customer base as of mid-year 1990

2. Software

Like the services estimates, all software estimates are derived from installations. Revenues for 1990 are the product of the number of installations made in 1990 and the average price of the software/installation plus revenues from maintenance fees on the existing customer base. INPUT assumes that 80% of a software vendor's revenues come from new-installation sales and 20% from maintenance fees.

The software component includes revenues derived only from EDI translation software. Application software that has built-in EDI capabilities is not counted in this market estimate.

3. Professional Services

This category includes the professional services provided by software vendors and network service providers as well as independent professional services firms, based on the total number of companies and consultants that offer professional services. INPUT estimates that there are approximately 35 to 40 individual consultants (including consultants belonging to the big six accounting firms) and another 10 companies that provide consulting in addition to software and/or network services (such as IBM, Sterling Software, GEIS, Harbinger, etc.).

For the individual consultants, INPUT assumes that the average yearly gross on EDI professional service consulting is \$500,000. For the larger/multi-offering companies, INPUT assumes their average gross for professional EDI services is \$1.5 million.



D

Data Presentation

1. Leading Vendors

Exhibits V-6 and V-7 display customer and revenue values for the leading network services and software vendors to the EDI market.

EXHIBIT V-6

Leading EDI VANS 1990

Company	Estimated 4Q-89 Customers	Estimated 2Q-90 Customers	Estimated 4Q-90 Customers	Derived 89 EDI Revenues (\$ M)	Derived 90 EDI Revenues (\$ M)
GE Information Services	4,500	5,300	7,050	18.0	21.2
Sterling Software/ Ordernet	1,700	1,800	2,200	6.8	7.2
Harbinger	1,200	1,500	2,000	4.8	6.0
Control Data Redinet	1,000	1,100	1,500	4.0	4.4
Sears	700	1,100	2,090	2.8	4.4
BT Tymnet	750	1,050	1,250	3.0	4.2
IBM Information Network	900	1,000	2,250	3.6	4.0
AT&T	50	500	750	0.2	2.0
Kleinschmidt	470	500	550	1.88	2.0
Railinc	400	400	400	1.6	1.6
Transsettlements	350	350	350	1.4	1.4
Telecom Canada	300	300	300	1.2	1.2
Airinc	150	150	150	0.6	0.6
U.S. Sprint	50	75	75	0.2	0.3
MCI	40	50	50	0.16	0.2
CompuServe	50	50	50	0.2	0.2
INFONET	0	0	0	0.0	0.0
Total	12,610	15,225	21,015	50.44	60.9

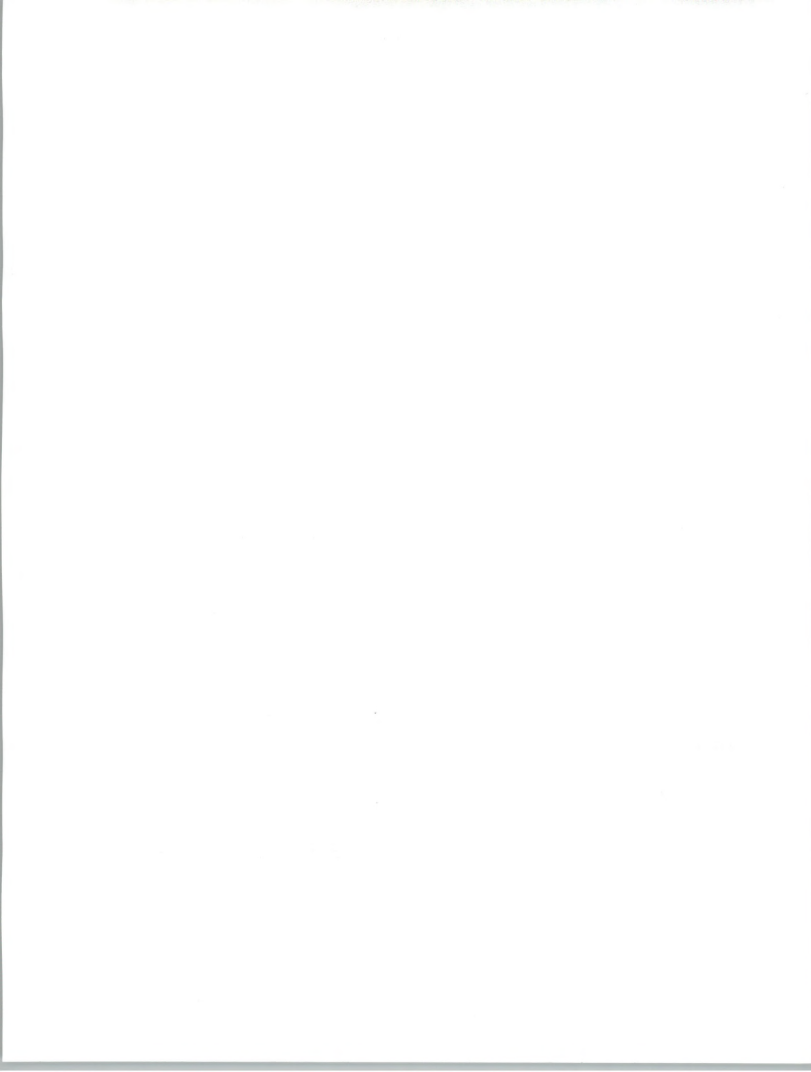

EXHIBIT V-7

Leading EDI Software Vendors 1990

Platform	Company	2Q-90 Customers	Estimated Weekly Installation Rate	August 1990 Price	Derived 1990 Revenues per Platform (\$ M)	1990 Installs
Micro	Supply Tech	3,300	45	2,295	6.4	2,250
	GEIS	2,000	20	1,450	1.8	1,000
	Harbinger	1,200	4	900	0.2	200
	EDI Inc.	1,300	2	2,600	0.3	100
	American Business Computer	1,100	3	3,500	0.65	150
	Foretell	900	2	2,025	0.25	100
	Sterling Software	800	4	2,000	0.5	200
	DNS	600	2	3,000	0.4	100
	APL Group	1,000	3	3,200	0.6	150
	RMS	800	2	1,950	0.24	100
	Piedmont	200	3	2,495	0.46	150
	EDS Canada	400	1	2,000	0.125	50
	Other	1,500	2	2,000	0.25	100
		Total	15,100			12
Midrange	ACS Network Systems	800	4	11,000	2.75	200
	Sterling Software	350	3	15,000	2.8	150
	IBM	300	1	9,500	.6	50
	Louis Wright	250		5,500	NA	NA
	Other	100			NA	NA
	Total	1,800			6.1	400
Mainframe	Sterling Software	350	1	50,000	3.0	50
	GEIS	250	1	20,000	1.25	50
	IBM	75	1	35,000	2.2	50
	EDI Solutions	160	0.1	27,500	0.2	5
	TSI International	160			NA	NA
	DEC		0.1	60,000	0.375	5
Other	200	0.1	35,000	0.22	5	
	Total	1,195			7.33	165

UNIX operating systems: American Business Computer, Perwill, Birmingham Computer Group, EDI Solutions

NA = Not available

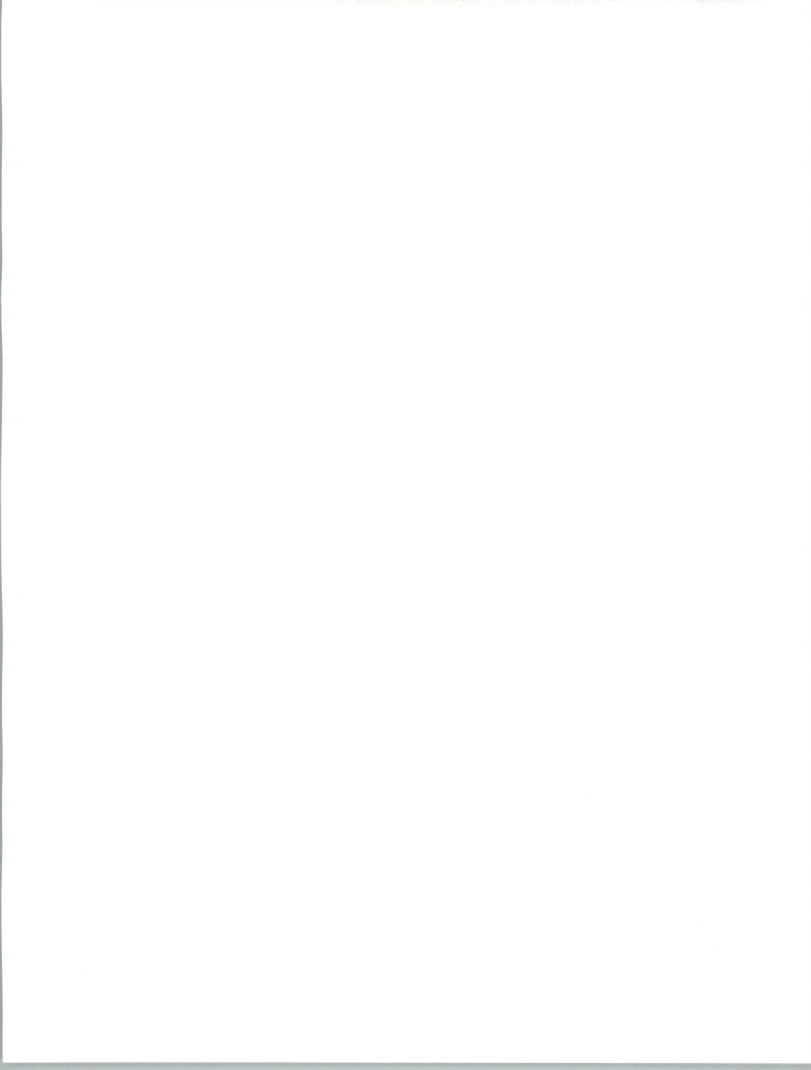

2. Market Size and Forecasts

Exhibits V-8, V-9, and V-10 show forecasts through 1995 for the services and software markets in EDI.

EXHIBIT V-8

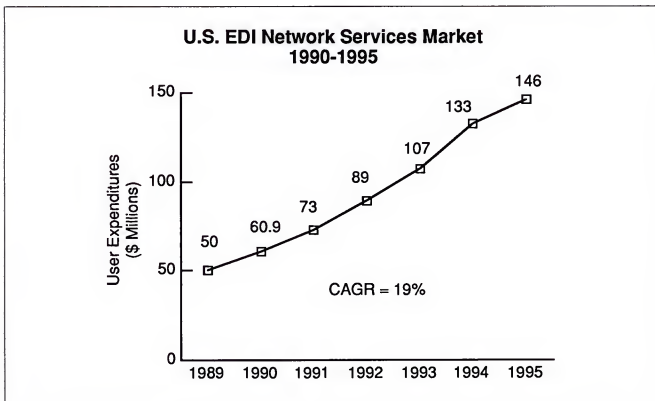

[The page contains extremely faint and illegible text, likely bleed-through from the reverse side of the document. No specific content can be transcribed.]

EXHIBIT V-9

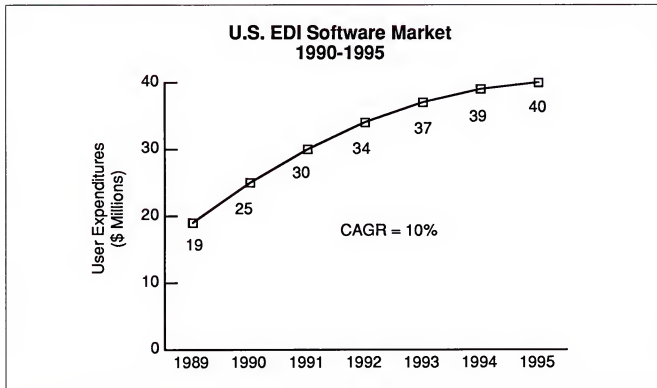
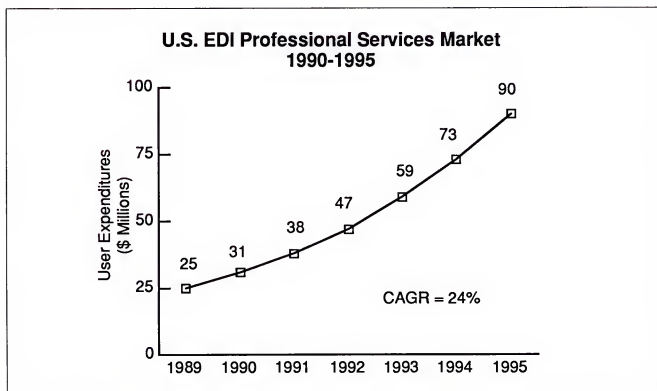

EXHIBIT V-10



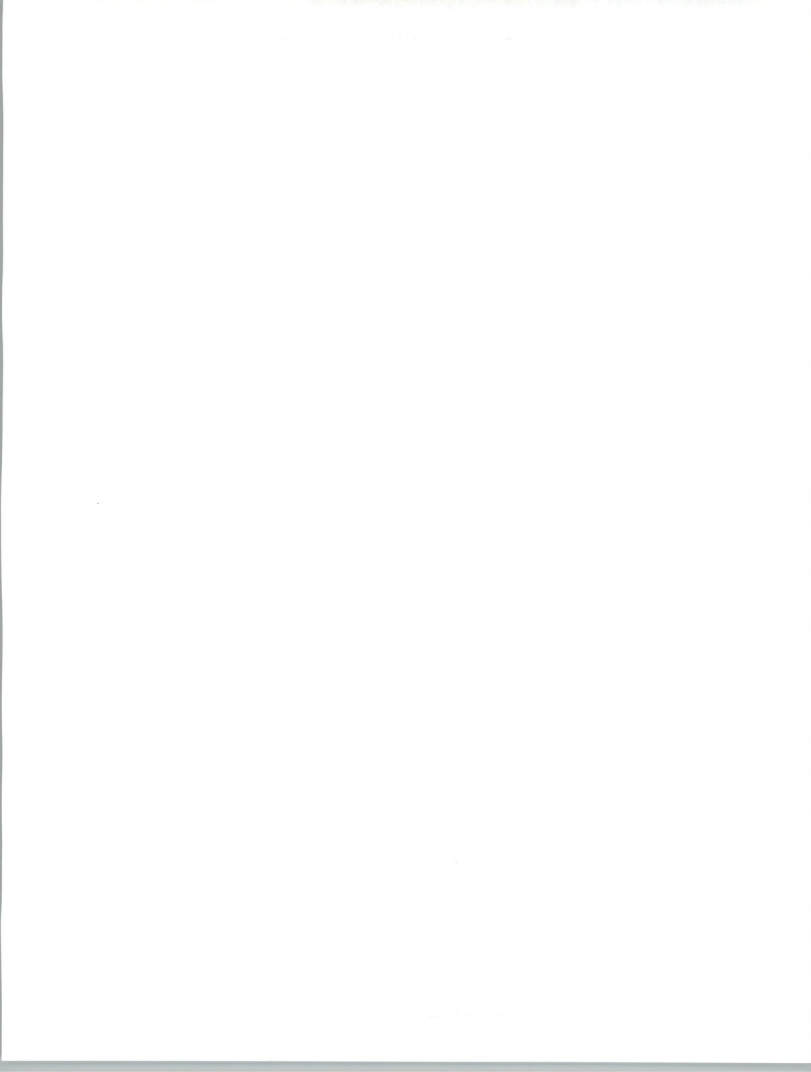

Exhibit V-11 shows the year-by-year growth forecast for the total U.S. market for EDI services and software.

EXHIBIT V-11

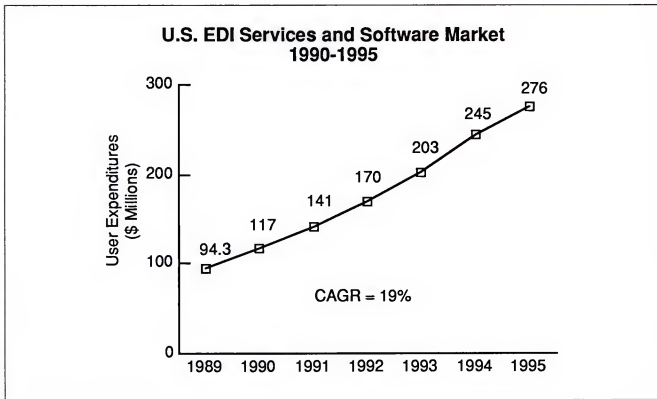

Exhibit V-12 graphically shows the magnitude change in the three delivery modes (software, network services, and professional services).

Exhibit V-13 shows the growth in the total EDI market.

E

Discussion of Forecast

Independent interviews with network service providers and EDI users confirm that the total number of EDI trading relationships should increase from the fourth quarter of 1989 to the fourth quarter of 1990 by approximately 7,000.

The absolute increase in new EDI users is somewhat less than the increase in relationships and is best approximated by the incremental growth of software installations. INPUT estimates the increase of new EDI users to be approximately 5,000, or 33% over 1989.

The total number of network customers at the end of 1990, approximately 21,000, should not be equated with the absolute number of EDI users. There is a significant portion of double-counted users in this

EXHIBIT V-12

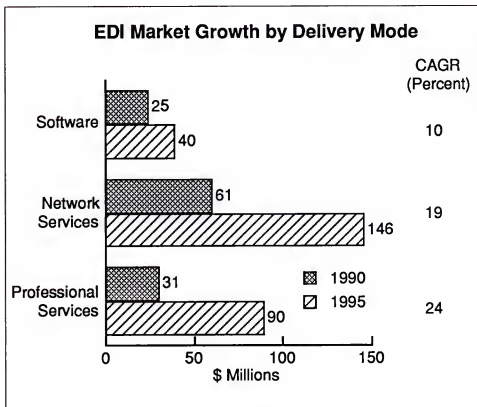

EXHIBIT V-13

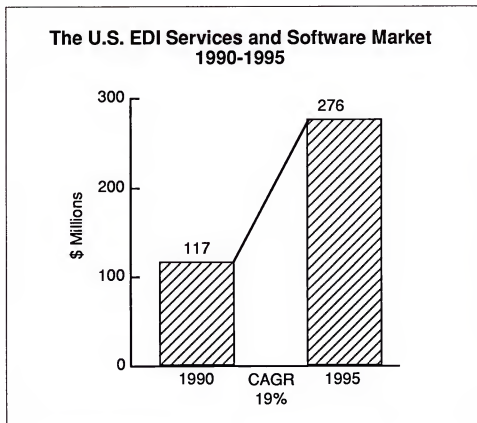

figure because, according to INPUT's user survey, 24% of companies use more than one network. The figure therefore is higher than the actual U.S. EDI user population.

Revenue growth for suppliers to the EDI market will be less than the 33% growth in absolute size. INPUT estimates that the market for EDI services and software is currently growing at a compound annual growth rate of 19%.

- The market for EDI services and software should reach \$276 million by 1995, up from 1990's \$117 million.
- INPUT projects that a leveling off will occur in the EDI market.

There are various phenomena that suggest this leveling off.

- According to user research, network charges level off despite additions of new EDI trading partners. Often the new trading partners account for a very marginal volume of EDI transmissions. Also, as users optimize their systems, they send less data per commercial transaction to each other.
- A "macro" eighty-twenty rule may apply to the economy, in that 80% of the GNP is produced and distributed by 20% of the companies. (Actually, the distribution is much more skewed: of the \$5.1 trillion GNP of 1989, the Forbes 500 accounted for \$3.2 trillion (62%) and the Fortune 500 accounted for \$2.1 trillion (41%).) When all key producers of the economy get up and running in EDI, the marginal value of bringing on more users is nil.

When this leveling off will occur is hard to predict. Furthermore, the leveling off effect may be postponed as the world economy becomes ever more integrated—integration that triggers an increase in demand for electronic interorganization systems.

INPUT estimates that the market for EDI software is more mature than the market for network and professional services. This can be seen in Exhibits V-8, V-9, and V-10. This is due to the fact that the total universe of potential EDI-using companies is much smaller than the potential number of trading relationships among these companies. INPUT believes that the annual growth rate in the number of EDI-using companies is falling off. But the growth rate in EDI trade relationships is continuing to expand. Also, explaining the younger market for services, once a company begins using EDI it has already made its main software expenditure but it usually increases its network usage year by year. The maturing of the software market will be more pronounced in the main-

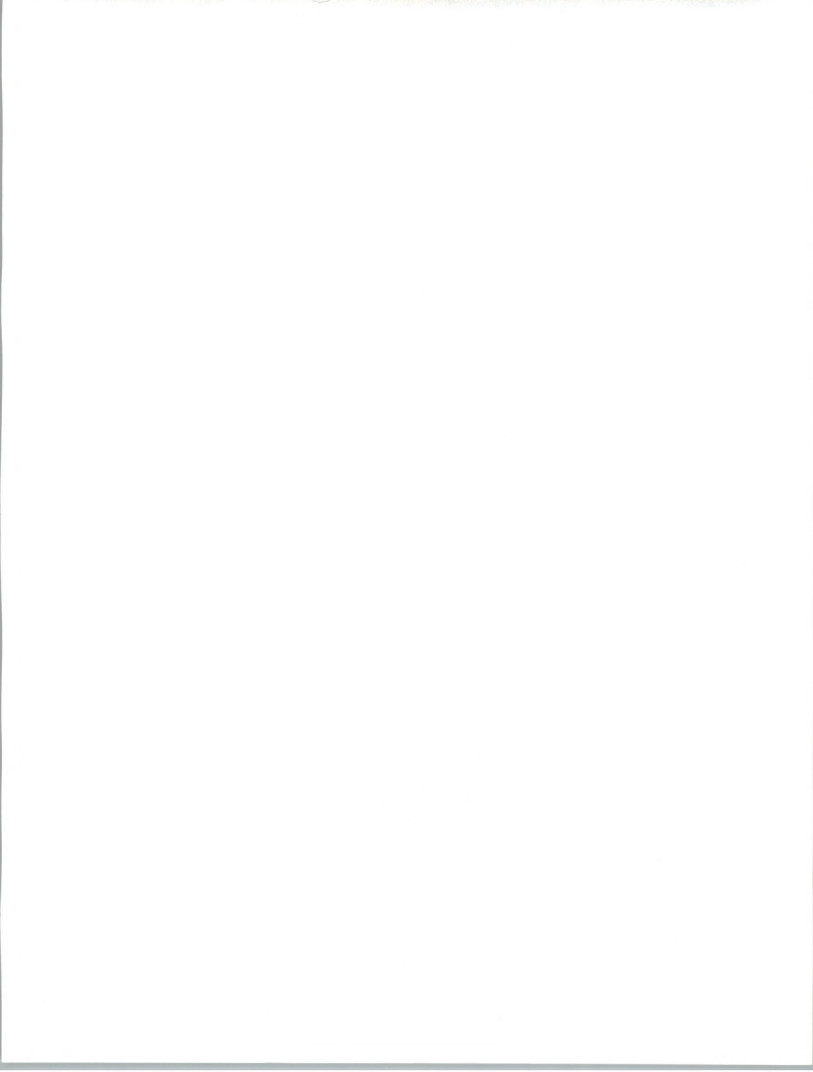

frame/midrange markets and not so much in the micro markets; the latter, however, contains the smallest marginal revenue impact (i.e., despite a large number of new installations, overall growth in revenue may be unimpressive).

F

Reconciliation with Earlier INPUT Forecasts

This report's forecasts and market sizings are considerably smaller than earlier INPUT forecasts. The reasons for this are:

- INPUT's former forecasts have not defined EDI as rigorously as this report has. All values represent expenditures on strictly X12, UCS, TDCC, WINS, EDIFACT and large proprietary systems (such as Sterling Software's Eagle, Wal-Mart's system, or Sears' SENDEN).
- Earlier market forecasts included all of North America. This forecast examines just the U.S. (mention of Telecom Canada is included due to a significant customer base and/or trade relationships with U.S. companies).
- Revenues from non-EDI-related offerings from vendors are not included in this report's forecasts as they were in former forecasts.
- Values do not reflect other batch data transmissions that are not specifically identifiable as EDI.
- Values do not include such EDI-like systems as Transnet, IVANS, medical claims, or semi-EDI systems (such as the Securities and Exchange Commission's EDGAR system). These systems, being captive and with limited capacity for extension or growth, are not pertinent to EDI users and vendors who are examining the possibilities of EDI.
- Values are related to EDI that is performed over public third-party networks. Private networks and EDI via magnetic and diskette tape exchanges are not included in the market size numbers.
- After five years of monitoring the EDI market a closer, more precise picture is now possible with distinctions between true EDI and EDI-like activities. The result is a smaller market size and better analysis of probable market growth.

A statistical reconciliation of this report's forecast with INPUT's 1989 forecast can be found in Appendix C.

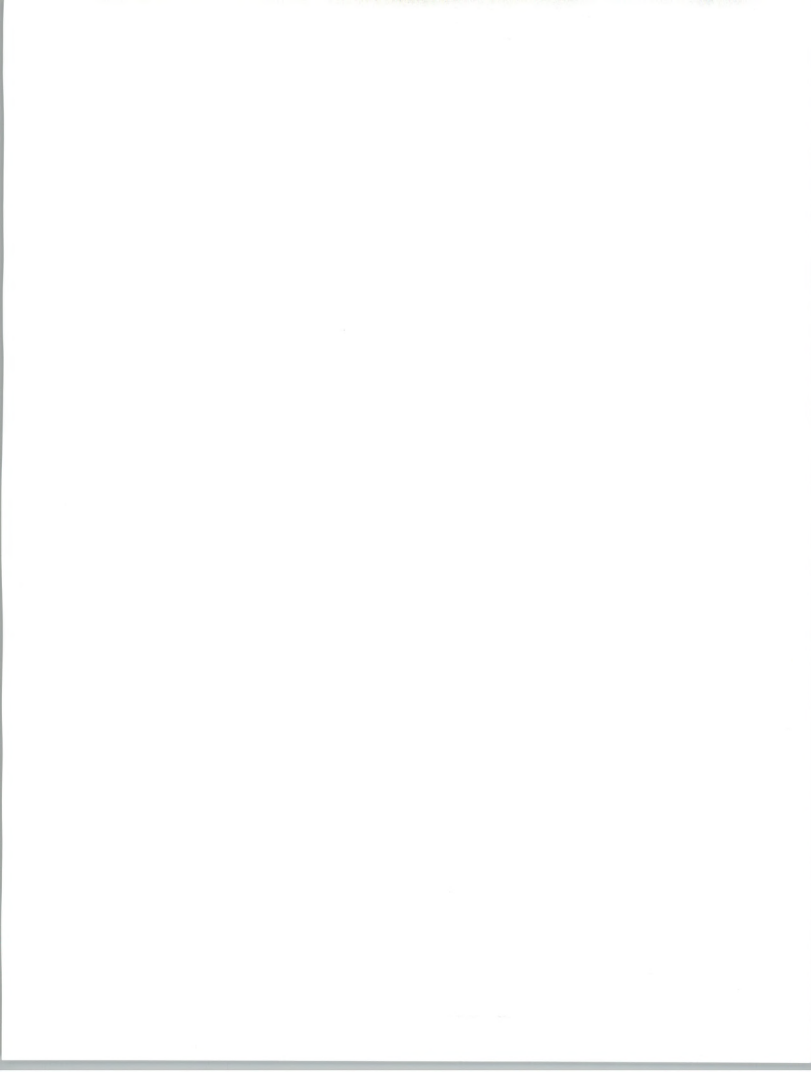

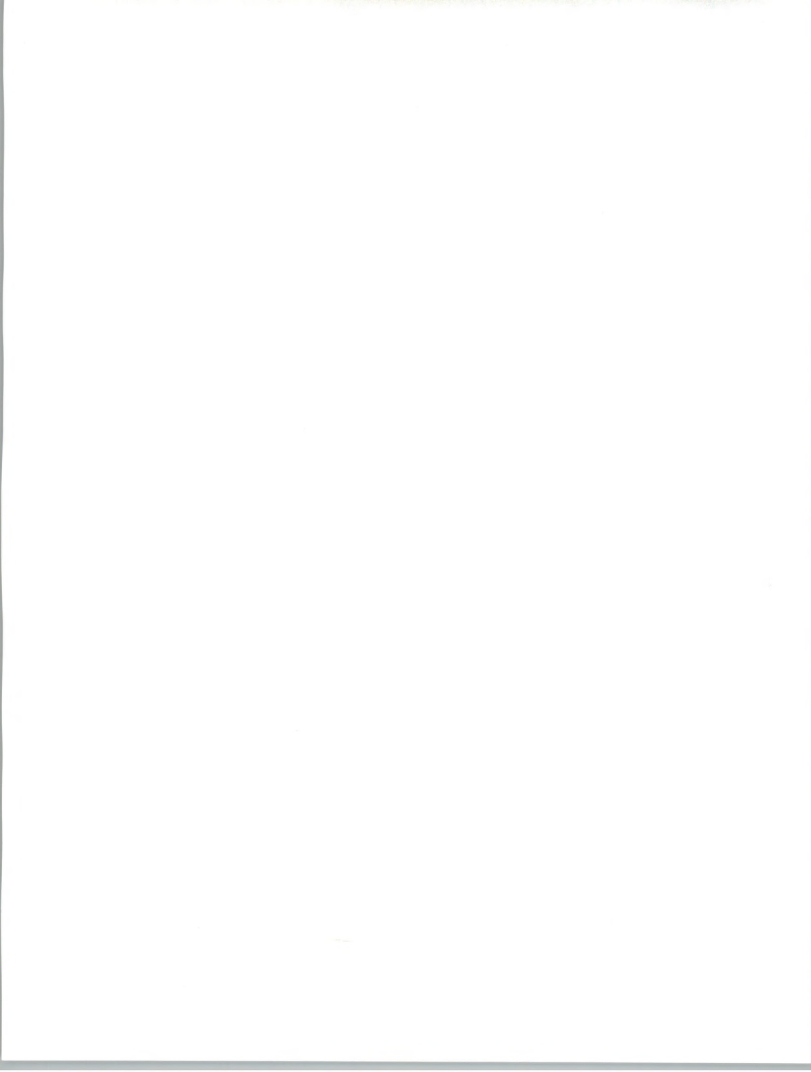



EDI Market Trends



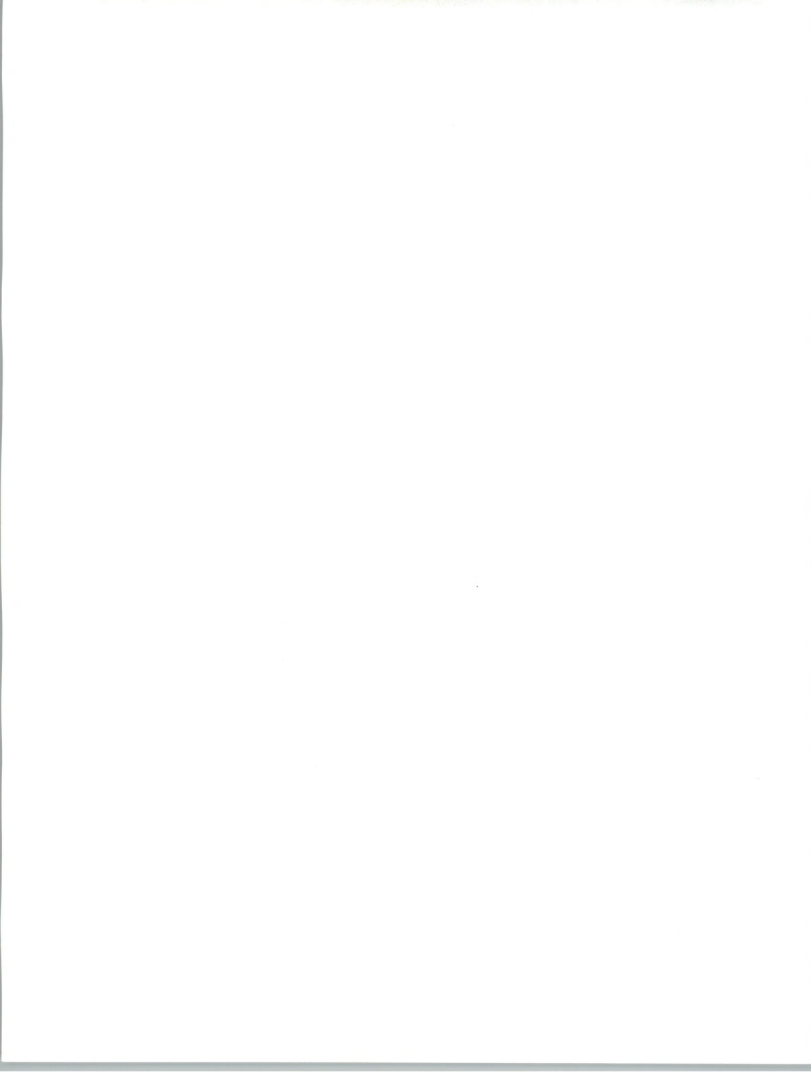



EDI Market Trends

A

Introduction

Meeting the needs of companies using EDI are software vendors, network providers, professional services firms, standards bodies, and, in some cases, a large hub company. Standards bodies are considered here, despite their non-commercial status, because they are constitutive, infrastructural components of the EDI market.

The suppliers to the EDI market are just as varied as the costs and benefits of EDI are difficult to allocate.

Products and services are provided by third-party vendors as well as large hub users. Software, network services, and consulting can be procured from a single source or many sources.

Exhibit VI-1 illustrates how users and vendors in the EDI marketplace do not fall into mutually exclusive categories.

The exhibit shows how a single company may be two or more of the following: EDI user, EDI software vendor, and EDI network service provider. The four combination categories and their constituent company representatives include the following:

- User/Network Provider: Motorola, Ford, General Motors, Chrysler, and major banks.
- User/Software Vendor: Levi Strauss, Abitibi-Price, Extol
- Software Vendor/Network Provider: Sterling Software, Railinc, GE Information Services, Harbinger, Control Data, and many banks
- User/Software Vendor/Network Provider: American President Companies, SeaLand, CSX, Wal-Mart, Sears, General Electric, Union Pacific, IBM, EDS, Federal Reserve, Digital Equipment Corporation

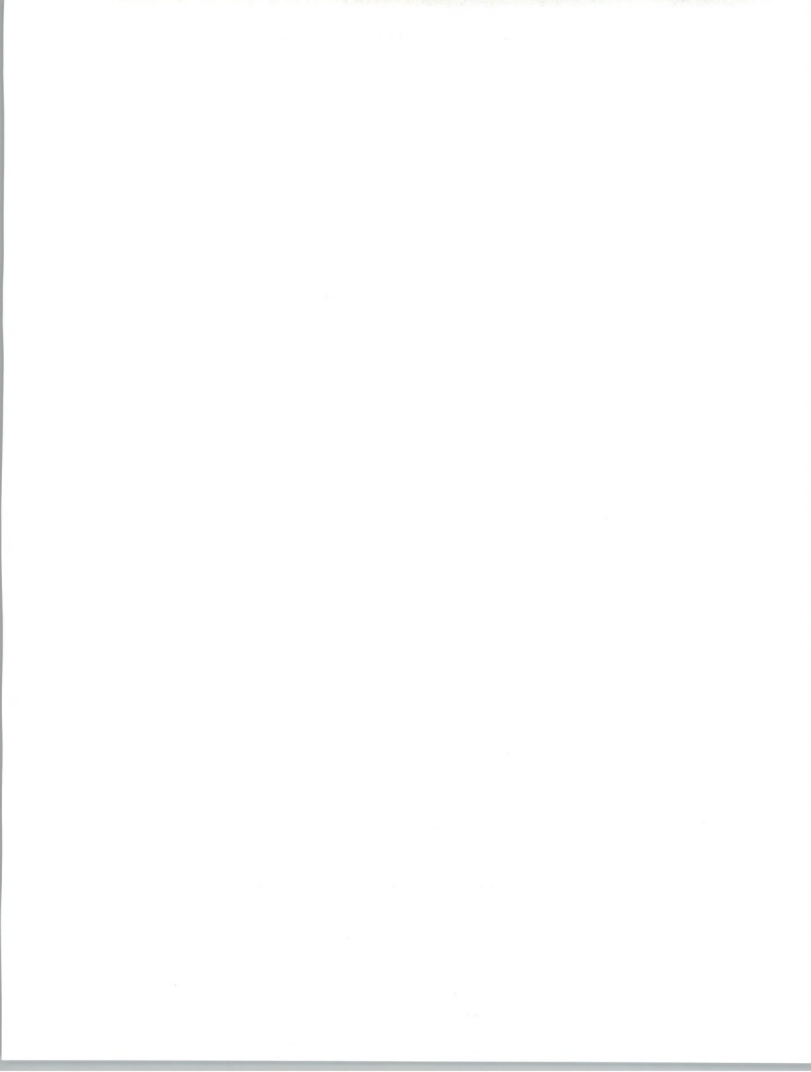
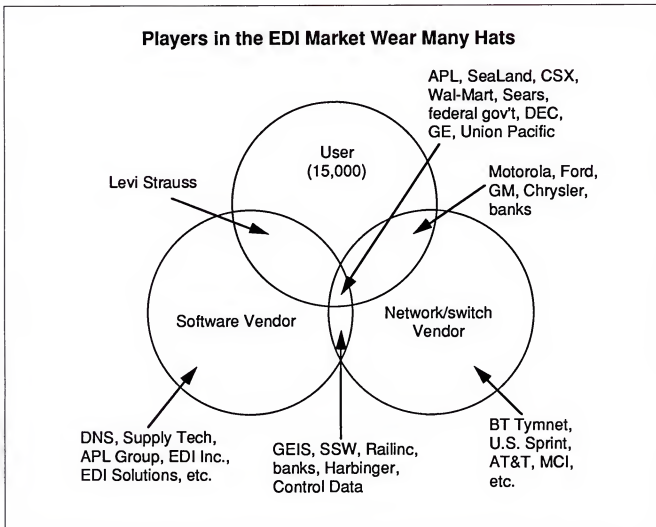

EXHIBIT VI-1



Reasons for the fluidity of player categories in EDI include:

- *Historical tradition.* EDI was traditionally introduced by large companies either as a cost reduction measure (as is the case with mass merchandisers or large manufacturers), to offer a customer service (as is the case of transportation companies), or to provide a strategic link with customers (such as American Hospital Supply). These early promoters of EDI soon found that they could in turn offer the expertise that they had developed by selling software or services (Sears and GE are good examples of this).
- *Hub company subsidization.* The costs and benefits of EDI are not easily ascertained nor evenly distributed among two EDI trading partners. Often the hub company has more to gain than one of its small spoke suppliers. EDI to the hub means all suppliers are reachable



electronically. EDI to the spoke means an investment of \$5,000 to \$10,000 just to keep a single customer happy. Often the large trading partner (such as Sears) will subsidize the cost of bringing up its trading partners.

- *Proliferation of internal corporate networks spurred by increasing availability of inexpensive, basic data transport service.* Corporations are finding they can build their own data networks by leasing lines from telephone, VAN, satellite, or other kinds of telecommunication providers (such as Williams Communications Group, formerly an oil and gas pipeline company that began stuffing its pipes with fiber optic cable and is leasing usage).
- *Increasing price/performance levels of communication gateway software.* Software that performs store-and-forward/switching functions is now under \$100,000. Corporations are discovering that they can interface directly with trading partners using dial-up telephone lines and in some cases can create their own networks.
- *The costs of EDI education dissemination are changing.* One of the great inhibitors of EDI is that it is not widely understood by enough of the right people. Getting the right people (executives) to understand EDI requires input from many different educational channels: in-house, from trading partners, from third-party consultants, from vendors of products, from trade media. In the case of EDI, education is critical to the EDI sell. Because the EDI awareness level among business managers is (slowly) increasing, the party responsible for financing the cost of EDI education (vendor, trading partner, user) changes frequently.
- *Mergers and acquisitions.* Users and vendors may end up belonging to the same corporate unity. The purchase of World Trade Services (a customs broker that maintains a network for customs brokers) gave majority ownership to transportation user CSX.

The evolution of EDI players has resulted in a corporate schizophrenia where any two companies may simultaneously be each other's suppliers, customers, and competitors. For example, Pittsburgh National Bank supplies GE with financial services, competes with GE to provide corporations with electronic payment services, and it is a customer of GE for light bulbs. Digital Equipment Corporation buys semiconductors from, sells computers to, and is willing to sell EDI software to Motorola.

Technological development is particularly impacting the dividing line between EDI software and network services. Increasing price/performance of software is eroding some of the services of value-added networks. The blurring of functional domains of software and services is a trend that will be explored in this analysis.

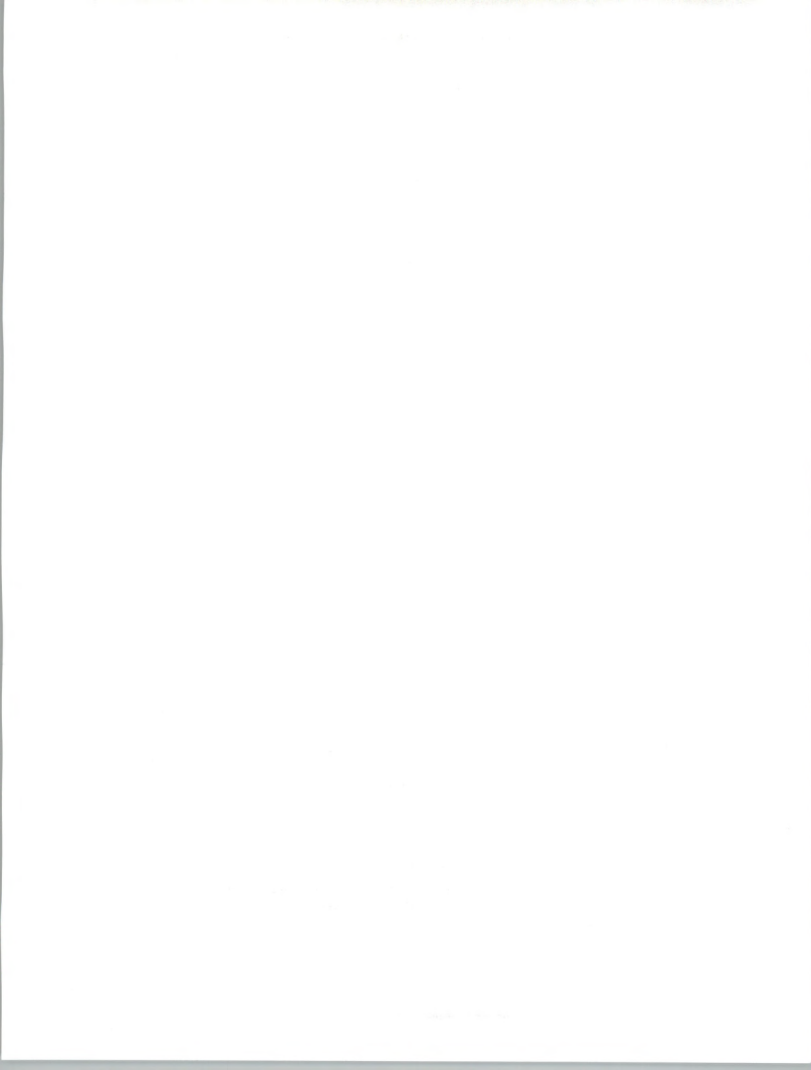

B
Software Products Exhibit VI-2 summarizes the trends in EDI software offerings.

EXHIBIT VI-2

Trends in EDI Software Offerings

- Migration of value-added network services to customer-site software
- Communication gateway/EDI server architecture
- Three-tiered market for message-switching software
- Event-driven and real-time architectures
- EDI interfaces built into application programs
- Inexpensive translation software/turnkey solutions
- New sources of EDI software
- Market consolidation
- EDI/EFT software
- Softness in midrange market
- Programming tools in translation software

1. Continued Migration of Value-Added Network Services to Customer-Site Software

Translation. The most notable service that was once offered almost exclusively by third-party VANs, but is now done almost exclusively on customer premises, is data format translation. The definite trend in EDI is for users to perform their own translation—once at the sender site, and again at the receiver site. This is certainly the case for users who conduct or plan to conduct large volumes of EDI. However, with the proliferation of micro-based translation software packages, even small companies are adopting on-site translation.

On-network translation, formerly a predominant service of third-party VANs and RCSs, is now used mostly as an interim measure by a small company until it installs its own EDI software.



The X.400 standard also promises to accelerate this trend. As messaging systems of large corporations are interconnected with public data networks using X.400 gateways, EDI will increasingly use X.400 envelopes, and use of the special VAN services for EDI (compliance checking, in-network translation, etc.) will decline.

Store-and-forward mailboxing. Software is available for under \$100,000 that allows corporations to establish their own networks. This is a direct threat to third-party networks. Vendors and users of these private network platforms, however, are not intending to supplant third-party VANs. Such platforms allow direct connections for only a handful of leading trading partners; the remaining EDI traffic is routed through VANs (see next trend for further details).

Exhibit VI-3 lists some of the key functions provided by EDI software and network services and identifies areas where overlap occurs.

EXHIBIT VI-3

Network versus Software Functionality		
Function	User Site Software	Network
Store and forward	✓	✓
Translation	✓	✓
Interconnection		✓
Real-time EDI	✓	
Transaction data bases		✓
Media conversion		✓ (or fulfillment house)
EDI to fax, E-mail compliance checking	✓	✓
Control reports	✓	✓
Trading partner program		✓
Telecom expertise		✓



2. Communication Gateway/EDI Server Architectures

In building or enhancing internal data communication networks, large corporations are installing "communication gateways." These are central nodes of a corporate network that route data flows within an organization (E-mail, remote job entry flows, real-time interconnections, etc.) as well as connect the data network of an organization with the outside world. The outside world may include direct connections with other organizations as well as connections to value-added networks. Communication gateway software provides extensive security, fault-tolerance, high-volume capacity, and high processing capacity. Many firms are using this software to front-end their EDI translator. Trading partners send transmissions directly to the gateway. The gateway routes the messages to the translator, then reroutes the translated messages on to the appropriate application(s).

Exhibit VI-4 lists vendors of mailbox communication gateways:

EXHIBIT VI-4

Vendors of Communication Gateway/EDI Server Software

- Sterling Software
- Mpact EDI Systems
- Digital Equipment Corporation
- American Business Computer
- Stratus/EDI Solutions
- Harbinger
- GE Information Systems
- Tandem
- SoftSwitch

INPUT's user research revealed that 32% of the users surveyed said that they are already using such communication gateways or are considering using them. Gateways in the survey were broadly defined to include computer systems that directly connected to computers in other organizations.

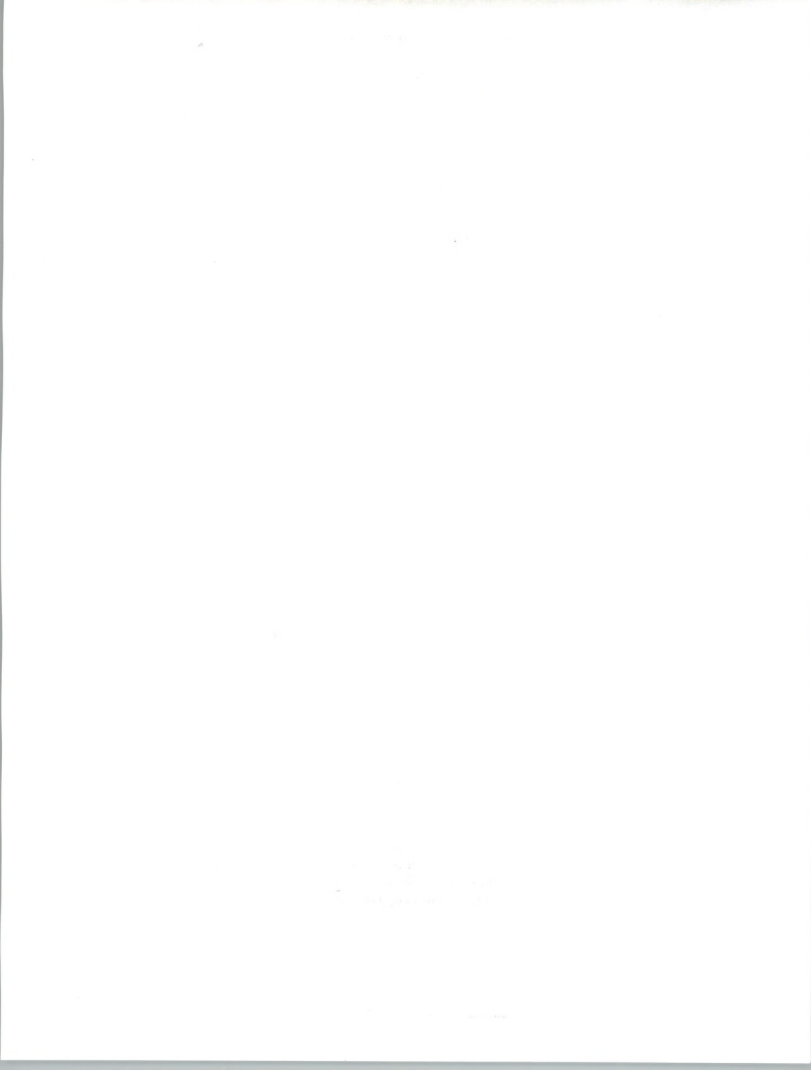
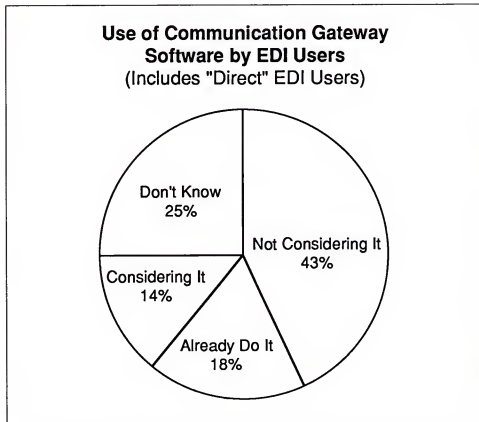

Exhibit VI-5 shows the percentage of users who maintain or intend to establish a data communication facility for direct connections with trading partners.

EXHIBIT VI-5



3. Emergence of a Three-Tiered Market for Message-Switching Software

Further underscoring the overlap in functionality between customer-owned software and network services, a three-tiered market is opening up for store-and-forward switching software. Exhibit VI-6 depicts the three types of switching software and some vendors.

Switch software is maintained by the EDI service provider (either a VAN or a remote computer service). It supports store-and-forward and other capabilities that allow EDI users to send documents to each other.

As already mentioned above, communication gateways are being installed by large EDI users. On a higher scale, network service providers are licensing their own switching software (the software that performs a VAN's EDI processing) to other network providers. Sterling has licensed its switch to Global VAN Japan; Harbinger has licensed its switch to Bell Atlantic; and AT&T's U.K. VAN, Istel, has licensed its switch software



EXHIBIT VI-6

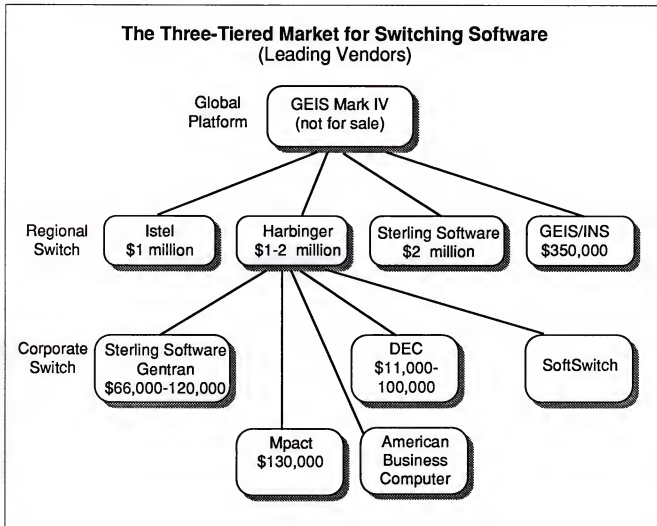

to Spain's Telefonica, Hong Kong's Cable and Wireless, and Italy's SEVA, among other sites. One level above the licensed switch software is the software (generally not for sale) of the largest networks, such as GEIS' MARK IV.

4. Event-Driven and Real-Time EDI Architectures

Two varieties exist:

- Real-time EDI processing can be established between two companies so that the applications of each company communicate directly with each other. Users in the automobile industry and passenger transportation industry are calling for this non-batch style of EDI. It requires a real-time telecommunication link, the sending of transaction sets one at

1870
1871
1872
1873
1874
1875
1876
1877
1878
1879
1880
1881
1882
1883
1884
1885
1886
1887
1888
1889
1890
1891
1892
1893
1894
1895
1896
1897
1898
1899
1900

a time, and transaction-processing-style applications. Real-time transmissions present a large challenge not only to traditional EDI but to the OSI model, as both of these architectures are fundamentally based on the store-and-forward concept. Chrysler processes advanced ship notices in real time. (More information can be found in INPUT's *Advanced EDI Services* report.)

User need for real-time connections is significant. Exhibit VI-7 shows the percentage of respondents to INPUT's survey that use or would like to use real-time connections with trading partners.

EXHIBIT VI-7

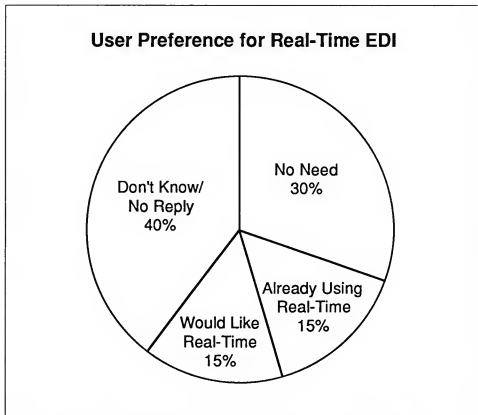

- Real-time or "event-driven" processing occurs within a single company: an application (e.g., order entry) communicates in real time with the EDI translator. The translator receives and sends messages with the outside world in a batch mode. Inside the company's information system, software moves EDI messages in and out of applications on an as-needed basis instead of according to a rigid, predetermined batch schedule. Such software, instead of moving messages from application to translator and back again in batches, prioritizes messages. It moves important ones quickly through processing sequences while holding others for traditional batch processing. For example, a purchase order from a customer who is operating in a just-in-time mode could be



moved by the receiving company's translator directly into the company's order entry system while other non-JIT purchase orders would queue up for evening processing. American Software (Atlanta, GA) has order entry software that works in an event-driven mode with Sterling Software's Gentran translation software.

Exhibit VI-8 depicts the processing flow of event-driven EDI.

EXHIBIT VI-8

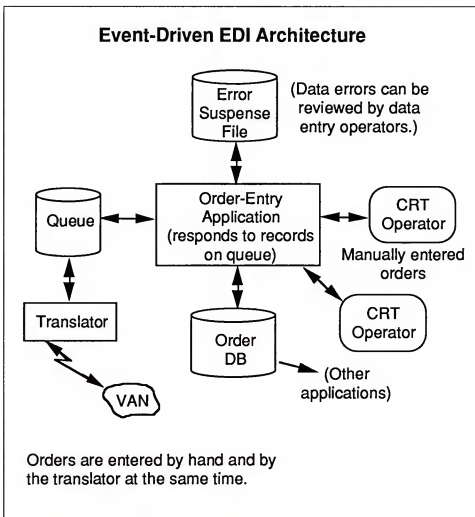

5. EDI Interfaces Built into Application Programs

To facilitate the integration of translation software with application software, some application software vendors are building EDI application interfaces into their application software. Targeted applications that are being made "EDI-ready" include purchasing, order entry, warehousing/shipping, and accounts receivable/payable. TSI International, a developer of data entry software, purchased the rights to



Transtlements' EDI translation software, Translate, and is developing a product that integrates hand data entry with EDI data entry. Application software houses American Software and Dun & Bradstreet Software Services (formerly McCormack and Dodge and Management Sciences of America) are building interfaces to Sterling Software's Gentran translation software. Alliances between application software houses and EDI translation software houses can be tricky. Sharing market opportunities and customer support responsibilities is difficult to sort out equitably and clearly. Technical issues are not the central problem in making application software compatible with translator software—marketing agreements are.

Exhibit VI-9 lists application software developers who are building EDI into applications.

EXHIBIT VI-9

Vendors of EDI-Ready Software Applications

- American Computer
- Oracle
- Digital Equipment Corporation
- Dun & Bradstreet Software Services
- TSI International
- IBM (MAPICS, COPICS)

6. Inexpensive EDI Software for Turnkey Implementations

More and more large companies are requesting that all trading partners—even small suppliers who do small trade volumes—be up and running on EDI. These small trading partners are not willing to spend \$10,000 just to satisfy a single client. Instead, they buy stripped-down PC software for less than \$1,000. It allows them to communicate with the large company much like a facsimile machine: no integration with internal applications, and limited to communication with only a single network.

VANs (IBM, Harbinger, Sears) are pushing this concept.

- In its QuickEDI program, IBM installs inexpensive PC-based software with a large company's many trading partners.

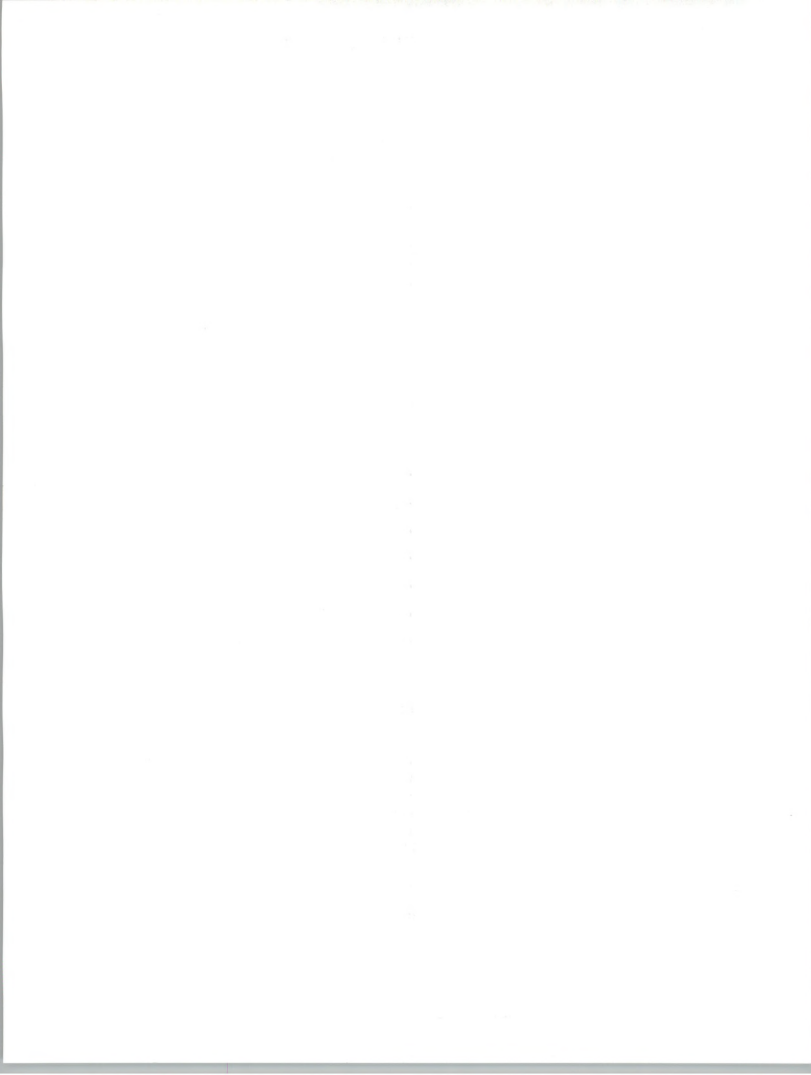

- Harbinger's software costs \$900 but is limited in functionality: it connects only to the Harbinger network and it cannot be integrated with internal applications.
- Sears is providing translation software (partly made by Piedmont Systems) free to its 5,000 trading partners. The software can connect to other networks.

A handful of independent software vendors (Baggerly & Associates, Lloyd Bush Inc., DNS) are focusing on this niche, but potentially large, market. Exhibit VI-10 lists software companies selling less-than-\$1,000 EDI software.

EXHIBIT VI-10

Vendors of EDI Translation Software for Less than \$1,000

- Baggerly and Associates
- Harbinger
- Lloyd Bush
- DNS
- IBM

7. New Sources of Software

Large hub companies, industry consortia, and/or industry trade organizations provide software for trading partners. Because the economic benefit of EDI often accrues to the large hub company and is merely an expense to the small spoke company, hub companies or groups of hub companies are providing their trading partners with software for free or for a minimal fee.

Exhibit VI-11 lists companies and/or consortia that are providing EDI software to their trading partners.

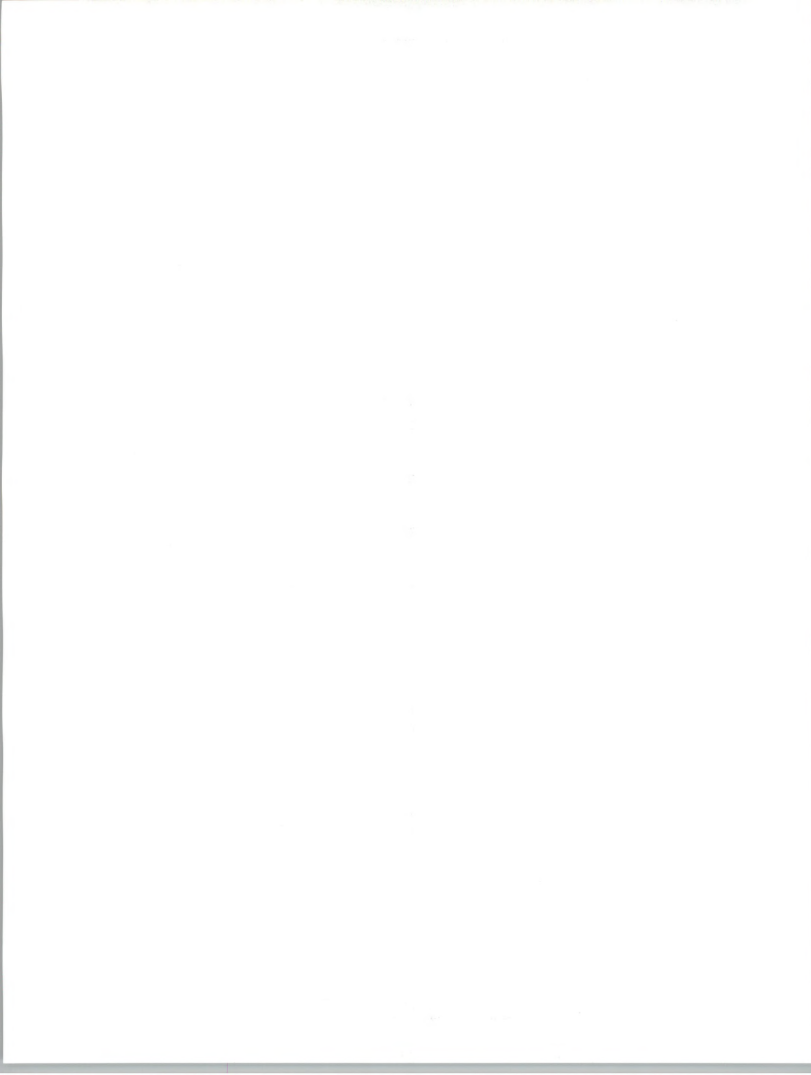

EXHIBIT VI-11

Non-Vendor Sources of EDI Software

- American Iron and Steel Institute
- Abitibi-Price (paper manufacturer) (Abitrol software)
- Levi Strauss & Company (Levi Link software)
- R.J. Reynolds (contracted with Piedmont Systems)
- National Electrical Manufacturers Representative Association
- Sears
- The Federal Reserve
- National Retailers and Merchandisers Association

In conjunction with the trend of new, non-vendor sources of EDI software, some EDI-using companies have become vendors of EDI software and are actively marketing the software they have developed to all potential EDI users. Exhibit VI-12 lists companies who have done this.

EXHIBIT VI-12

EDI Users Become Software Vendors

- Extol
- ACS Network Systems/Premenos
- Sears
- GE (Customer-Originated Electronic Payment software)

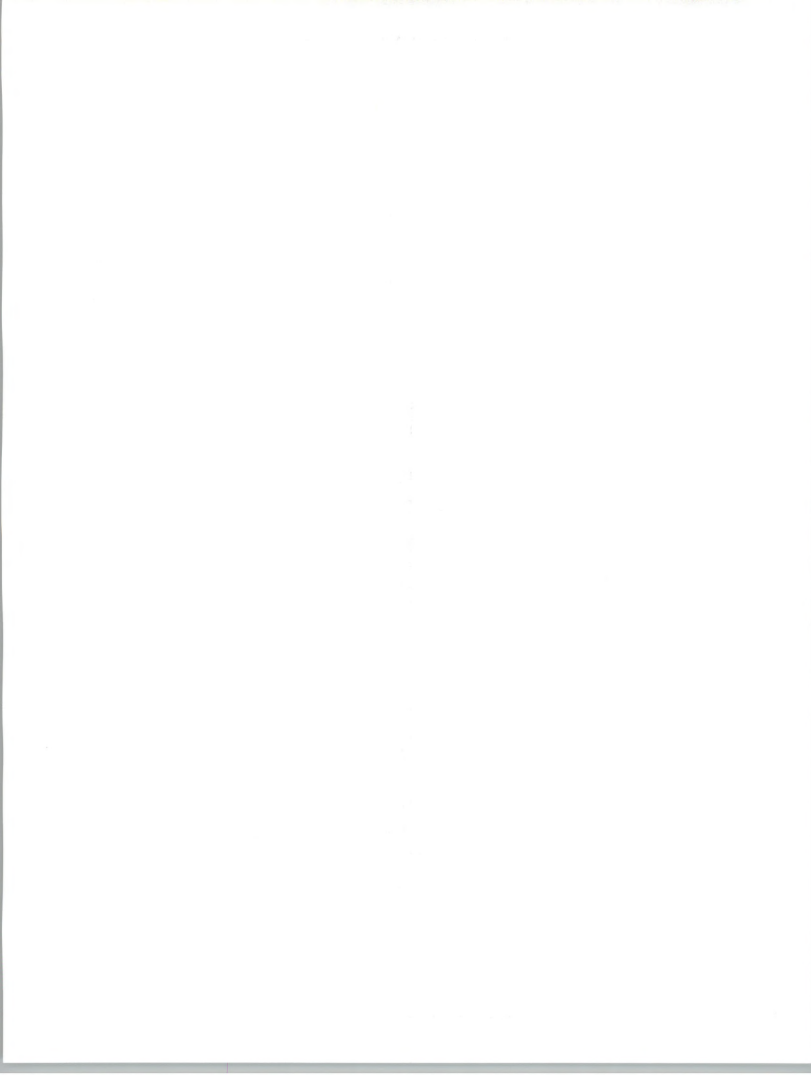

8. Market Consolidation through Mergers and Acquisitions

To broaden product line and to capture market share, a number of acquisitions took place in the past year among vendors of EDI software or related software. The trend is also spurred on by the oversupply of vendors in the market. Profit margins have been low, as EDI has not grown as fast as expected and many suppliers have entered the market.

Exhibit VI-13 lists the significant acquisition activity.

EXHIBIT VI-13

Significant Acquisition Activity Relating to EDI Software

Acquiring Company	Acquired Company	Date
Sterling Software	Metro-Mark	March 1990
TSI International	Transsettlements (software only)	March 1990
Dun & Bradstreet/ McCormack and Dodge	Management Sciences of America	Nov. 1989

9. EDI/EFT Software

There are two submarkets in electronic funds transfer software for EDI functions:

- Software at the user site
- Software at the bank site

See Chapter VII, section M-1, Finance/Banking for a listing of software vendors and products.

10. Softness in EDI Software for Midrange Systems

The midrange platform (IBM System 36, 38, AS/400; DEC, and HP systems) is the least-used hardware for running EDI translation software. INPUT's user survey found that only four percent of users interviewed use a midrange platform. Of the total number of software installations in the second quarter of 1990, midrange sites represented 11 percent of all sites. Users typically opt to implement on either microcomputers or mainframes.



Exhibit VI-14 depicts user preferences for EDI platform.

EXHIBIT VI-14

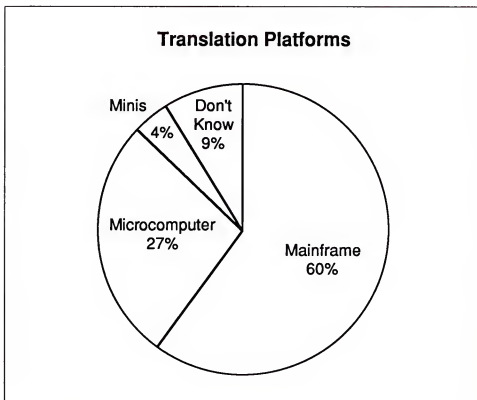

Micros will often be used to “front-end” other computer hardware (including midrange systems) that runs a company’s applications.

It is strange that midrange systems are not used more frequently, since they are well established in the manufacturing and distribution industries—the same industries where EDI is the most prevalent. Furthermore, there are hundreds of thousands of midrange systems, where there are only tens of thousands (possibly as few as 15,000) mainframes installed in the U.S. The market potential for minis seems large but actual implementation favors the high and low ends.

11. Programming Tools in Translation Software

To help users integrate translation software with applications, vendors are offering programming tools. Tools include data mappers (a standard feature in leading software), application program interfaces (such as Digital Equipment), and menu overlays (Supply Tech). ACS Network Systems/Premenos is developing a fourth-generation language called EDI/E that can be embedded in application programs (much like SQL).

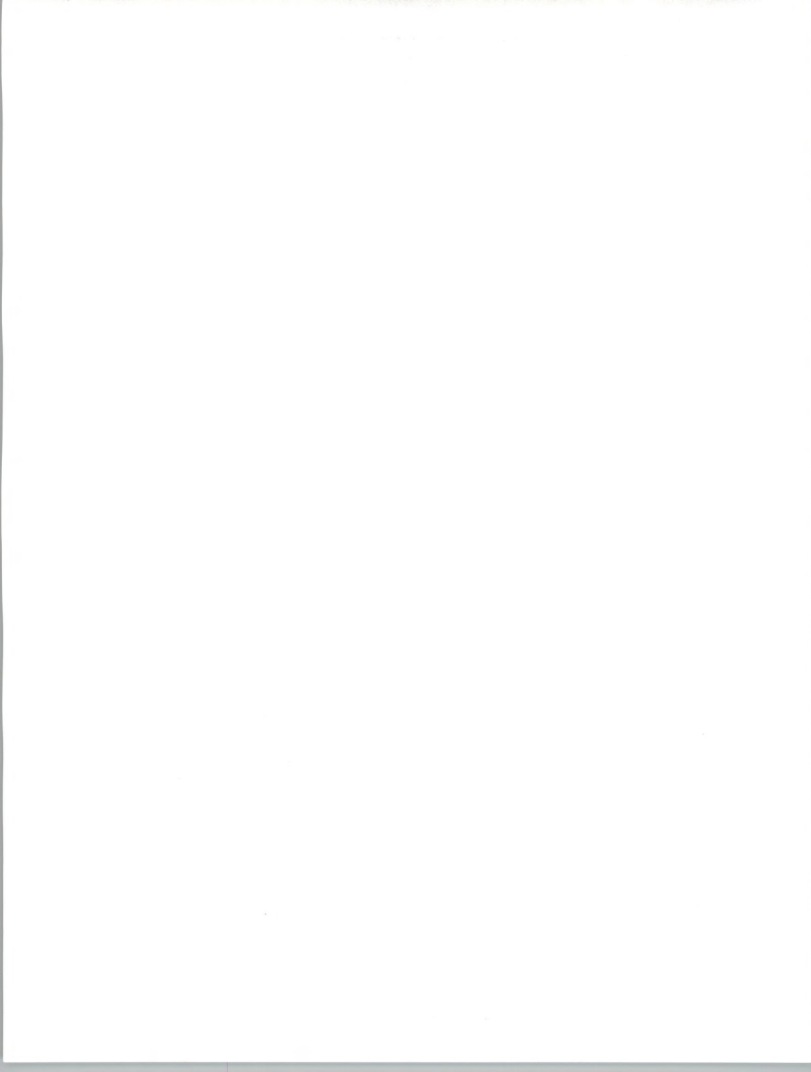

C**Network Service
Trends****1. Summary of Trends**

Exhibit VI-15 summarizes the trends in network services.

EXHIBIT VI-15

Trends in Network Services

- Market consolidation
- International expansion
- Internetworking
- Financial EDI services
- Real-time services
- Data transmission becoming low-profit business
- New value-added services introduced
- Offerings in software systems integration and consulting services
- Switch software being sold/licensed

Network service providers are undergoing the following trends:

a. Market Consolidation through Mergers and Acquisitions

To extend geographic reach, to buy market share, and to consolidate too low or zero profit operations into a more efficient scale, major acquisitions have taken place.

Exhibit VI-16 lists prominent acquisitions.

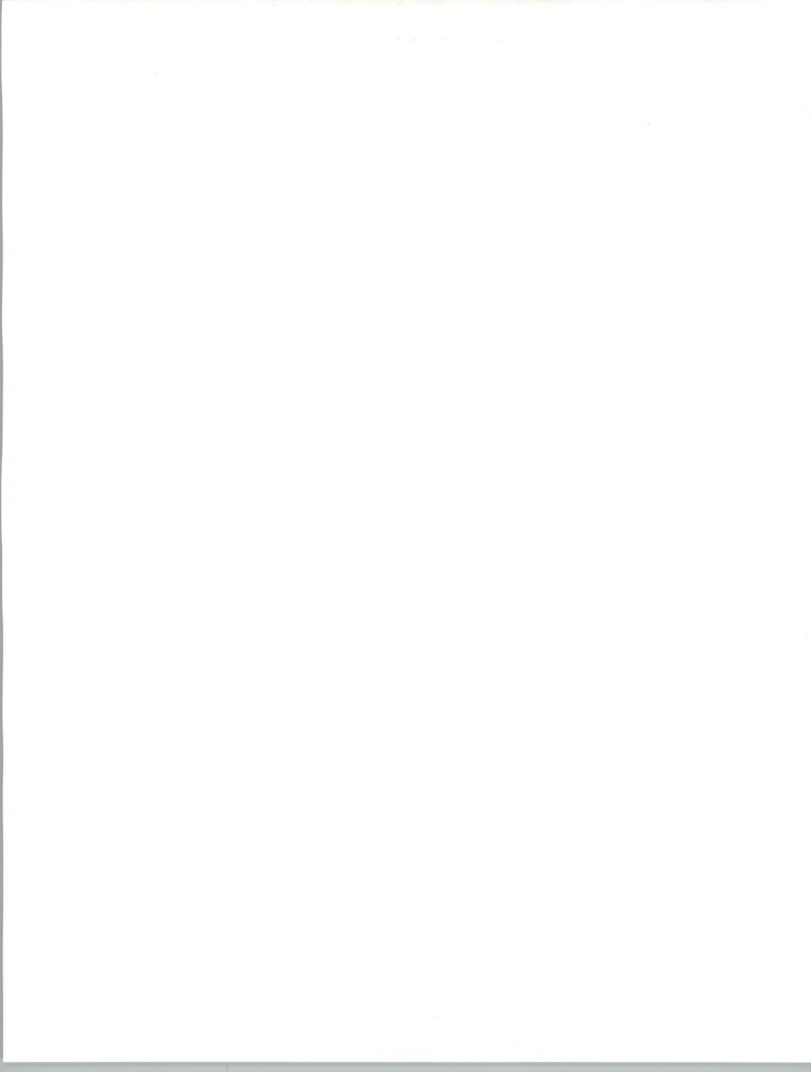

EXHIBIT VI-16

Prominent EDI Network Acquisitions

Acquiring Company	Acquired Company	Date
British Telecom	McDonnell Douglas Network Systems	August 1989
AT&T	Istel (U.K.)	September 1989
AT&T	Western Union	July 1990
MCI	INFONET (25% share only)	January 1990

b. International Expansion

Closely related to acquisition activity, leading service providers are aggressively developing global network capacity either through alliances, partnering with PTTs, or the installation of wholly owned facilities. GEIS and AT&T are building and buying more switching centers in Europe and Asia. Sterling Software Ordernet has made an alliance with a Japanese VAN (Global VAN Japan). Infonet (25% owned by MCI) is interconnected with several PTTs in Europe and is interconnected with other VANs around the world.

International EDI (EDI across national boundaries) is insignificant to the activity within U.S. boundaries. Even connections with Canada are small.

Exhibit VI-17 illustrates the results of INPUT's 1990 user survey.

The main users of international EDI are large multinational companies or core industrial companies, such as chemical, automotive, and aerospace companies. The international transportation and trade community (customs authorities, steamship lines, ports, etc.) are also some of the first users of international EDI. An experimental linkage between South Korean apparel makers and Sears Canada is underway.

EXHIBIT VI-17

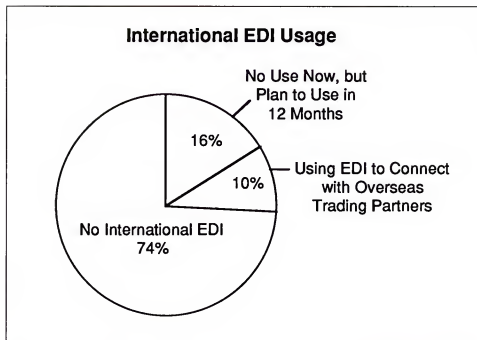

EDI is still largely a domestic activity. Early substantial EDI traffic across U.S. borders may first take place with companies in Canada and Mexico. Canada is close and already has a well established EDI infrastructure. Mexico is lacking in infrastructure but has many offshore manufacturing operations that supply or are owned by U.S. industrial companies.

c. Internetworking

All leading EDI VANs are interconnected, allowing a user on one network to communicate with a user on another. However, X.400 is not yet the medium of interconnection for EDI message traffic (despite its use for E-mail interconnection among the same VANs). The 3780 protocol is widely used at this time to interconnect public networks for EDI.

According to users surveyed for this report, 44% use the interconnection services of their networks. Exhibit VI-18 illustrates interconnection use for EDI.

In the survey, it was found that 24% of EDI users subscribe to more than one network, while 76% subscribe to only one.

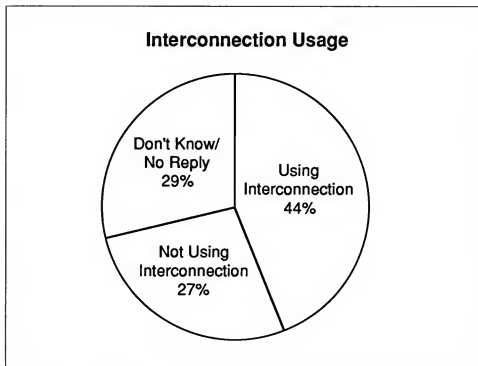

EXHIBIT VI-18

**d. Financial EDI Services**

To support customers who want to pay trading partners electronically, networks and banks are offering EDI/EFT services. In most cases, VAN partnerships with banks have formed to provide these services. According to this arrangement, corporations pay suppliers electronically by transmitting payment instructions to their bank via the service provider's network. The bank acts on these instructions by sending electronic payments to the supplier's bank via the banking industry's Automated Clearinghouse or, if the supplier's bank does not have a way to receive an electronic payment, by sending a check in the mail. The service provider communicates the remittance information to the supplier via its network.

GEIS has taken a different track from its competition. It is not allied with any one bank. Its payment and collection services work with any bank. One service, Customer-Originated Electronic Payment (COEP) is aimed at companies that want their customers to pay them electronically. GEIS extends data communication links to these customers. Customers pay bills to COEP, which then routes the payment instructions to the appropriate banks involved.

INPUT research found that only 22% of EDI users are currently using financial EDI services (to either pay suppliers or receive payment from customers).

Exhibit VI-19 lists the leading VAN/bank alliances.

EXHIBIT VI-19

Leading VAN/Bank Alliances

Value-Added Network	Bank
IBM Information Network	First Chicago Corporation
Sears Communications Co.	Eight U.S. banks (Bank of America, Continental Bank, CoreStates Financial Corp., First Wachovia, Harris Bank, Mellon Bank, National Bank of Detroit, and the Northern Trust Bank)
BT/Tymnet	Security Pacific Corporation
CDC Redinet	Mellon Bank
Harbinger	Consortium led by Citizens and Southern

e. Real-Time Communication Sessions

The impact of real-time EDI systems on OSI architecture is unknown. ISDN lines have yet to be used for EDI. Chrysler has an agreement with GEIS for "fast-batch" processing of advanced ship notices.

f. Data Transmission a Commodity, Low-Profit Business

Value-added services are migrating to customer premises (data format translation, store-and-forward mailboxing, etc.). The data communication business is highly competitive.

g. New Value-Added Services Introduced

Introduction of new services is in response to data transmission becoming a commodity business. Some service providers are going beyond offering basic data transport functions to customers. EDI data bases, media conversion services, and transfer of binary files (e.g., CAD/CAM files, spreadsheets) with EDI documents are new services being successfully marketed today.

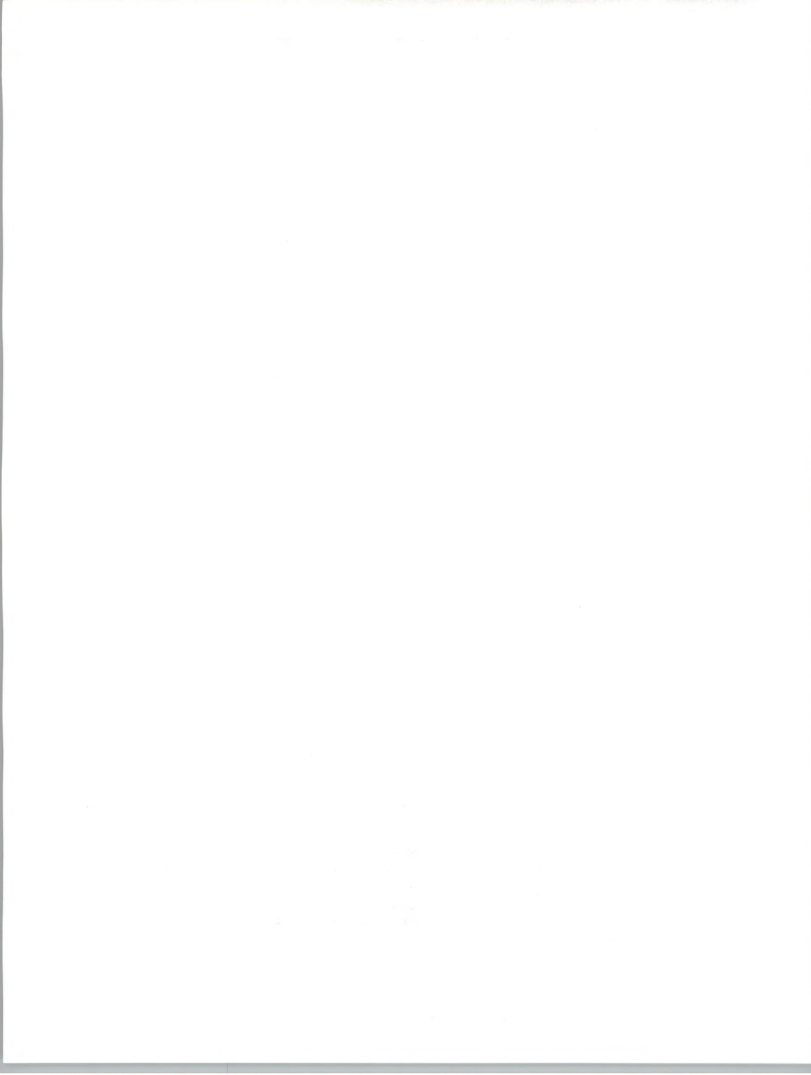

Commercial EDI data bases are of two types. Product catalogs (offered by IBM and GEIS) allow retailers and apparel suppliers to keep product listings, UPC bar codes, and prices synchronized. Transaction data bases (offered by Sterling Software Ordernet) track EDI message traffic to compile statistical reports on sales and distribution activities. Another data base of potential value to customers is a trading partner data base. Such a data base lists companies that are EDI-capable and the details of the company's business (SIC code) and the technicalities of communicating with it via EDI (e.g., kinds of transactions used, data mappings, transmission schedules, etc.). Trading partner data bases can be used to help businesses find other businesses.

- IBM and Sterling Software maintain such data bases electronically. IBM allows its customers to access the data bases electronically.
- First Interstate Bank is using its EDI customer data base as the basis for a business brokering service.
- Dun & Bradstreet is interested in using the ANSI X12 Trading Partner Profile (transaction set 838)—planned for use primarily by government contractors—to update its commercial company data bases.

Media conversion services are aimed at trading partnerships where one partner is EDI-capable and the other is not. All EDI messages emanating from the EDI-capable partner are converted to facsimile, E-mail, telex, or paper mail media and forwarded to the non-EDI-capable partner by the service provider. Some service providers are offering reverse services as well—they will input data from non-EDI media. Western Union and Sterling Software Ordernet are providing these services. Smaller service bureaus in the automobile industry are also providing such services.

Sending binary files attached to EDI messages is a growing service need, particularly among manufacturing companies. Parceling out component manufacturing to subcontractors (as in the automobile or aerospace industries) often involves sending design specifications, plans and documentation along with requests for quotes or purchase orders. Subcontracting and the consequent transmission of design and graphic information between companies is the modus operandi of the apparel industry. Attaching binary files to EDI documents is being done by GEIS in its Design*Express service and by the software provider Supply Tech.

Remote updating/maintenance of translation software is another new value-added service. The customer-site translation software that Sears is making available to its network customers is alterable by Sears if the customer uses it in conjunction with the Sears network. Updates to transaction sets, changes to mapping files, changes to menu screens, and changes to trading partner profiles can be made centrally by the Sears hub and broadcast to customers.

IBM Information Network's QuickEDI program helps large hub companies bring up all their trading partners in a single turnkey solution. IBM installs the appropriate software and hardware at all the trading partner sites. The service includes having IBM maintain the transaction set definitions, data mappings, and print and screen formats at the trading partner sites.

Although service providers are offering new value-added services, users still consider them primarily data transport providers. More than half of the users interviewed reported that they use their VAN(s) strictly for data transport and nothing else, as shown in Exhibit VI-20.

EXHIBIT VI-20

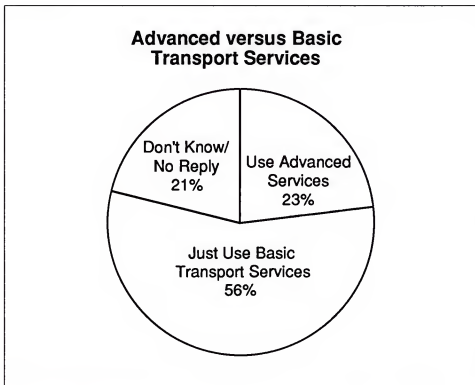

h. Service Providers Offering Software

GEIS, IBM, and Sterling Software Ordernet have a complete line of EDI translation software in addition to their network services. Control Data Corporation/Redinet launched a mainframe software package in the last quarter of 1989. Some of the packages of GEIS and IBM link customers only to their respective networks and not to other networks.

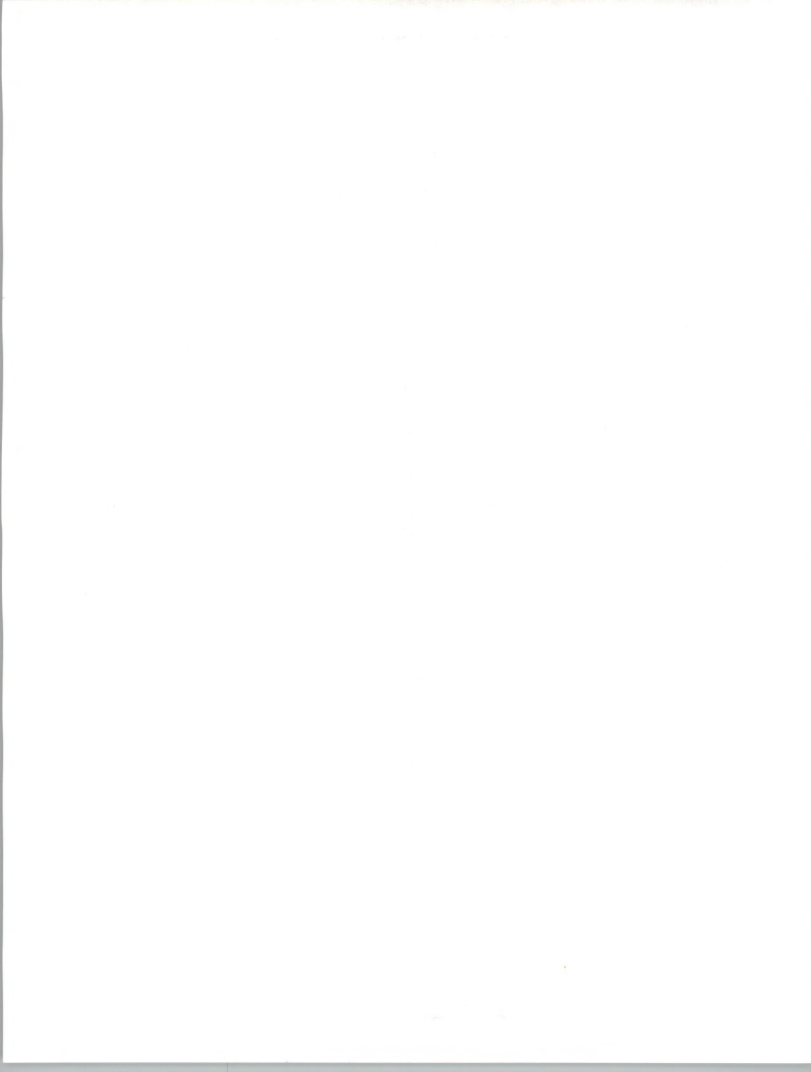

i. Service Providers Offering Systems Integration Services

Service providers are offering systems integration services aimed at bringing up a company's major trading partners in a single project. Such a service involves systems integration services at both the key client and its trading partner sites. IBM offers turnkey EDI solutions to large and small customers. Sears is offering similar services.

j. Service Providers Offering Educational and Consulting Services

EDI requires a long sell cycle. It is very education-intensive. Potential users must understand many issues—business and technical—before making an informed decision about adopting EDI. Thus, many network service firms are offering educational support to companies. These typically consist of one- or two-day seminars. Although many of the seminars charge admission fees (\$600 to \$1,000 per person per seminar), they are viewed by service providers as critical marketing tools.

k. Switch Software Being Sold or Licensed

See software trends above.

2. Similarities in Successful Service Provider Offerings

Today's successful EDI service providers are those who have won market share over the past eighteen months. These are Sterling Software/Ordernet, GE Information Services, and Harbinger Computer Services.

All three vendors have the following features in common:

- They offer an EDI implementation program for large accounts that want to bring up many trading partners.
- They offer EDI software for customer-premise data format translation.
- All three pursue a hub-and-spoke sales approach. In other words, they sell network services to a large company and to that company's trading partners.
- They all maintain an industry marketing orientation. Sterling is targeting grocery, pharmaceutical, transportation, hardlines, and retail. GEIS is targeting retail, oil, manufacturing, transportation, and banking. Harbinger has targeted utility companies and their suppliers, electronics, aerospace, paper, and metal manufacturers.

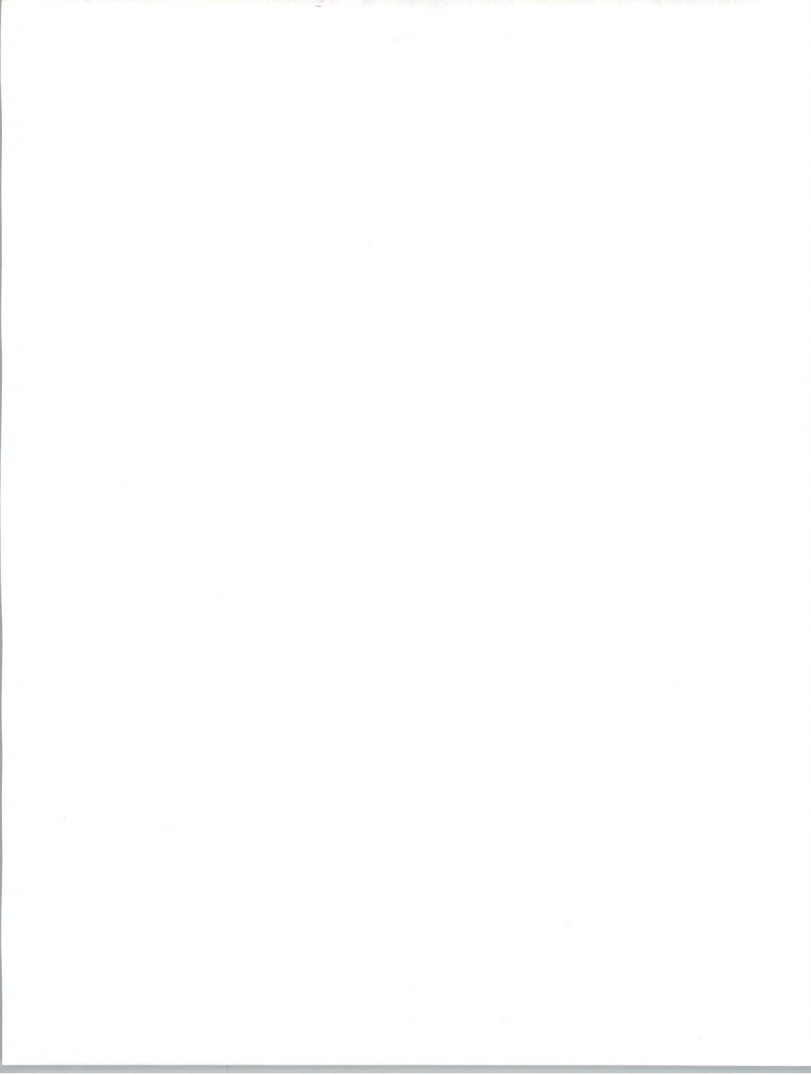

D**Professional Service
Trends****1. Background**

INPUT's research has revealed that only 30% of EDI users receive assistance from an outside source in implementing EDI. Assistance is provided most often by a network or software provider.

Although the initial implementation may have been largely handled by existing staff, INPUT believes that professional service consultants are being called upon to assist in advancing the original installation towards fuller integration with systems, and for upgrades from pilots based on PCs to full production systems hosted on mainframes.

Nearly 90% of users report that they have integrated EDI software with applications by themselves. In only 5% of the cases is it reported that the EDI software provider was used for this job.

The applications that users most typically integrate with EDI is (in descending order of frequency), order entry systems (67% of EDI installations), shipping freight bills/bills of lading (33%), purchasing systems (31%), billing systems (22%), accounts receivable (21%), inventory management (19%), logistics (15%), and accounts payable (15%).

2. Market Segments

The EDI professional service market can be divided into four segments: software development, consulting, education/training, and systems operations (sometimes called facilities management).

a. EDI Software Development

Services provided are user requirements definition, systems design, data base design, programming, testing, system modification, and documentation.

Market activators in this segment are:

- Conversions from microcomputer to minicomputer- or mainframe-based EDI implementations.
- Integration of EDI and applications such as order entry and accounting modules.

Providers to this segment are:

- Application software firms such as Dun & Bradstreet, (formerly Management Sciences of America) (Atlanta, GA), and Integral Systems (Walnut Creek, CA).



- Data communication specialists such as turnkey systems vendor Microbilt Corporation (Atlanta, GA).
- Network services firms such as GE Information Services (Rockville, MD) and Control Data Corporation (Minneapolis, MN).
- Banks such as First Chicago, National Bank of Detroit, and Security Pacific National Bank (Los Angeles, CA).

b. Consulting

Consulting plays two distinct roles in the EDI world:

- Cost/benefit analysis consulting helps the overall EDI sales process. More than 65% of the professional services firms surveyed by INPUT use cost/benefit analyses to help the sales process.
- Consulting activities which focus on the strategic role of EDI in large corporations give "pure" management consulting firms (such as McKinsey & Company and Booz, Allen, Hamilton) entrée to the EDI market.

The services provided include: identifying third-party networks, evaluating network suppliers, selecting communications and translation software, installation of translation software, data mapping between translator and application software, software security auditing, and information services management (positioning EDI in strategic information systems programs such as just-in-time or computer-integrated manufacturing).

Typical providers of consulting services are:

- Big accounting firms (Andersen Consulting, Price-Waterhouse, Deloitte-Touche, Ernst & Young)
- General management firms (A.T. Kearney, Arthur D. Little, McKinsey & Company, and Booz, Allen, Hamilton)
- Independent consultancies: EDI Education (Oak Park, IL), EDI Spread the Word (Dallas, TX), EDI Strategies (Marietta, GA), The Constell Group (Tenafly, NJ), Strategic Dimension Ltd. (Toronto, Canada), The EDI Group (San Francisco, CA), and R.J. York & Associates (Minneapolis, MN).
- Bank EDI consulting services: Security Pacific (Los Angeles, CA), First Chicago, National Bank of Detroit, and Pittsburg National Bank.

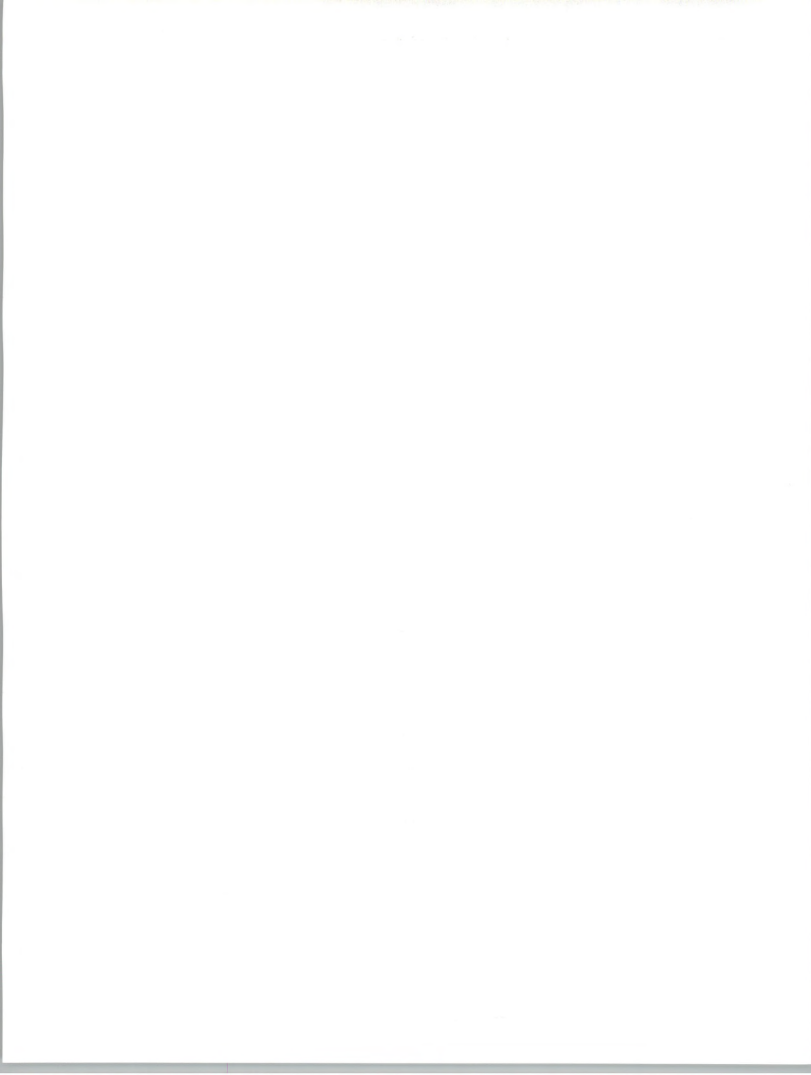

c. Education and Training

Education and training is the smallest segment in EDI professional services, but based on the number of EDI training and education seminars available, it has been experiencing accelerated growth.

Education and training services are important because:

- They are the foundation upon which vendors gain access to users.
- Users quickly learn about the benefits of EDI and are exposed to the technical aspects.

Providers to this segment are:

- Industry associations: TDCC/EDIA, the National Industrial Transportation League, American Trucking Association, American Electronics Association, Uniform Code Council
- Professional training organizations: Technology Transfer Institute (Santa Monica, CA), American Management Association (New York, NY)
- Colleges and universities: Large colleges and universities are offering courses on EDI (Harvard, MIT, Brigham Young University, University of Ohio, University of Wisconsin)

d. Systems Operations

This professional service, through which a vendor operates data processing centers for a fixed fee, has a narrow appeal in the EDI environment.

However, INPUT identified one situation in which an EDI vendor operated an EDI facility for a federal government agency. In this circumstance, a system operations contract was used rather than an outright purchase of computer equipment and enabling software, so as to use more plentiful operations and maintenance budgeted funds than procurement monies, which need to be authorized by Congress.

In another example of this approach, the Port of Baltimore implemented the ACROSS service to electronically support trade and customs documentation requirements. ACROSS is operated by Network Solutions (Vienna, VA) under subcontract with Andersen Consulting.



3. Trends in EDI Professional Services

The rapid growth of the EDI professional services market has led to:

- Segmentation of vendors by users
- Differentiation of vendor services through use of proprietary products

User firms are segmenting the market based on the size of the EDI professional services firm. The largest manufacturing, financial services, transportation, and utility organizations generally require the largest professional services firms.

A key characteristic of the professional services business is the flexible relationship between computer equipment vendors and vendors providing mainly services. In this segment, equipment vendors may team with professional services vendors for one project, then compete vigorously with one another for a different project.

In the next two or three years, EDI professional services vendors are likely to form alliances with specific equipment vendors.



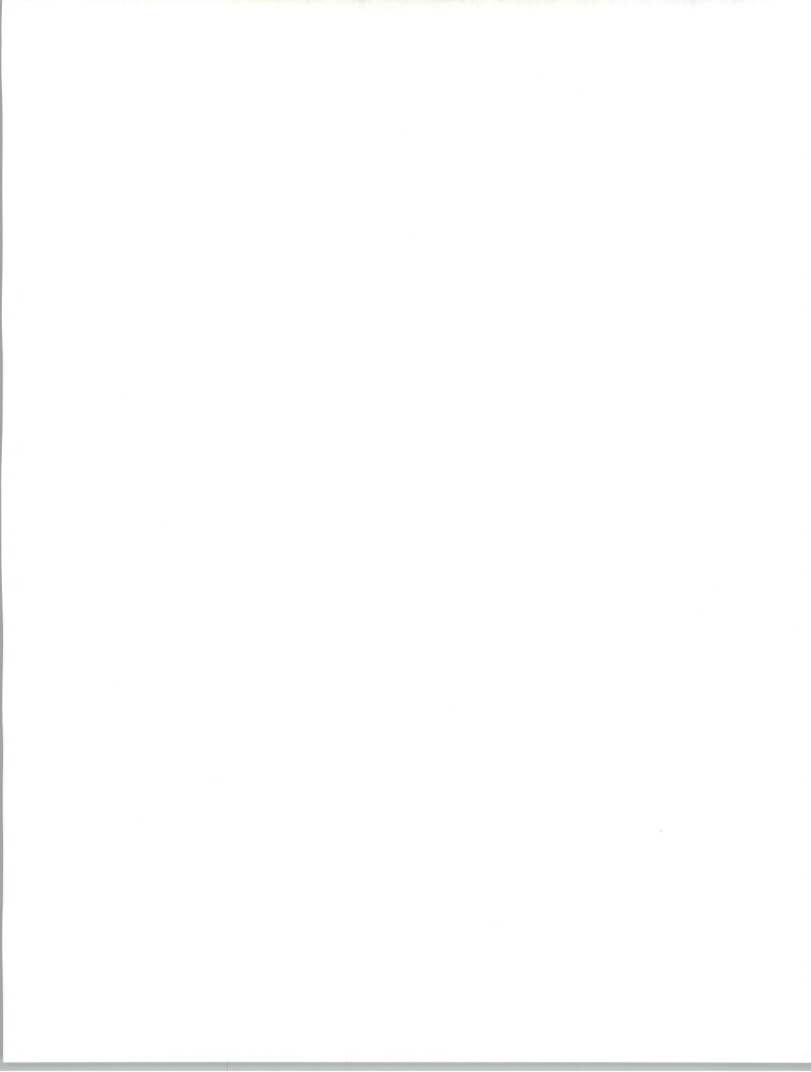



EDI Trading Communities and Applications







EDI Trading Communities and Applications

The following overview of EDI usage in the U.S. economy highlights major applications. It does not provide comprehensive coverage. Where appropriate, INPUT has highlighted advanced service needs of the various trading communities (such as EDI data bases, electronic funds transfers, etc.). Also, INPUT has provided statistics on the number of user companies involved in each trading community.

INPUT reviews these trading communities more or less in the order of the categories specified in the EDI Input-Output Matrix in Exhibits IV-1 and IV-2. Because the unit of analysis for EDI is whole value chains and not isolated industry groups, however, INPUT will analyze EDI applications across many industries in a single review.

A

Automobile Manufacturing

1. Autos and Trucks

The U.S. automobile industry is one of the most visible users of EDI in the world today. The big three auto makers launched some of the first proprietary EDI systems in the world back in the late 1960s. As a core manufacturing industry in the economy, it is a harbinger of the effectiveness of EDI.

Ford and Chrysler have estimated that EDI is responsible for cutting \$200 to \$400 from the cost of each automobile.

Intense global competition requires manufacturers to shorten lead times and to be able to quickly adjust to an ever-changing marketplace.

Although EDI is being used by auto makers in conjunction with such advanced applications as electronic payments and the sending of graphics files, EDI in the automobile industry is primarily concentrated on the interrelated objectives of:

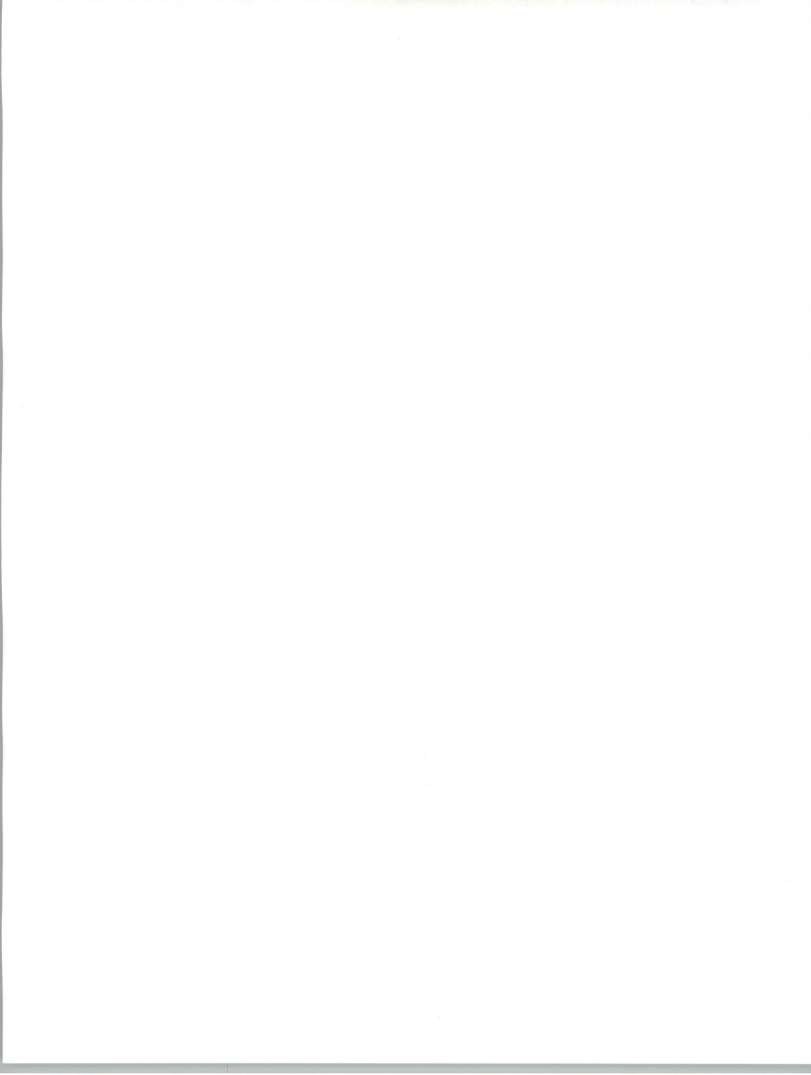

- Just-in-time parts supplying
- Reduced turnaround in auto production

These objectives involve two main EDI applications:

- The sending of production schedules/releases by the auto maker to the supplier (which acts like a purchase order)
- The sending of a shipping notice by the supplier to the auto maker (notifying that goods are on the way and acting as an invoice)

INPUT's survey of auto makers, suppliers and the Automobile Industry Action Group (AIAG)—a trade group which facilitates the industry's EDI implementation—has found these two applications to be present among all leading manufacturers and, in many cases, to be the only EDI applications practiced at all by suppliers and manufacturers.

For example, these are the only EDI applications that Mazda Motors of America conducts with its parts suppliers. It conducts EDI (in nonstandard, proprietary formats) with transportation vendors, however.

The volume of these two basic transactions among auto makers and their suppliers is high.

- Chrysler, for example, sends one delivery schedule once a week to approximately 2,000 of its suppliers.
- It updates these schedules daily to approximately 800 of the suppliers.
- In return, it receives approximately 1,000 ship notices per day. Goods cannot be received at Chrysler without an electronic ship notice first being sent.

There are two main directions in which EDI will grow in the auto industry:

- Toward more trading partners
- Toward more types of EDI transaction sets transmitted among trading partners

a. Trading Partner Growth

According to the AIAG, approximately 1,800 corporations in the auto industry conduct EDI. This accounts for approximately 3,000 sites.

1. The first part of the document discusses the importance of maintaining accurate records of all transactions and activities. It emphasizes that this is crucial for ensuring transparency and accountability in the organization's operations.

2. The second part outlines the various methods and tools used to collect and analyze data. This includes both traditional manual methods and modern digital technologies, highlighting the benefits of each approach.

3. The third section focuses on the challenges faced in data management and analysis, such as data quality, security, and integration. It provides strategies to overcome these challenges and ensure the reliability of the information used for decision-making.

4. The final part of the document discusses the future of data management and analysis, including emerging trends and technologies. It suggests ways in which organizations can stay ahead of the curve and leverage new innovations to improve their performance.

However, there are approximately 4,000 corporations in the total industry universe that could potentially conduct EDI, representing 6,600 sites.

These additional corporations are primarily suppliers of nondirect supplies to auto makers, such as office and equipment supplies and tools.

Suppliers to the suppliers of auto makers are another, albeit smaller segment where growth in trading partner relationships will occur. Many of the larger auto suppliers are developing just-in-time relationships with their suppliers and are implementing EDI.

However, even large auto suppliers generally have a small number of trading partners compared to auto makers themselves.

Federal Mogul, for example, a \$1 billion supplier of ball bearings, bushings, pistons, and other miscellaneous auto parts, conducts EDI with only 30 trading partners, most of whom are the principal auto makers. The company intends to double the number of EDI trading partners by mid-1991. Many of these new trading relationships will be with its upstream suppliers. Nevertheless, despite its size, Federal Mogul's EDI relationships will never approach the number found among the principal auto makers.

b. Transaction Set Growth

As noted above, the primary use of EDI in the auto industry is for sending purchase orders (actually production schedules/material releases) and ship notices. For many suppliers, these transaction sets constitute their entire EDI program.

The large auto makers, however, are also implementing electronic payments and EDI-connected graphics exchanges.

- General Motors pays all its suppliers electronically, despite the fact that only 15% of the suppliers can receive payment electronically. GM's bank consortia (headed up by First National of Chicago) cuts paper checks for those companies that cannot receive electronically. (Ford and Chrysler still cut paper checks and mail them.)
- The exchange of graphics files created in computer-aided design (CAD) applications is occurring among auto makers and subcontractors. Design information may accompany a request for bid and a bid acknowledgement; it may reside in an on-line parts catalog; it may be exchanged during a concurrent design cycle where a consortium of companies is working together to design and produce a single item.



The big three auto makers are experimenting with exchanging these documents and either referencing EDI documents or fitting the CAD file into an EDI document.

Also affecting transaction set growth is the conversion by the auto makers to X12 standard EDI formats. Since auto makers had their own systems and networks for proprietary EDI, a heterogeneous data format environment has existed.

c. Other Advanced Services

In addition to payments and graphics exchanges, new EDI services and applications are emerging in the auto industry.

- Service bureaus are helping tie together auto makers with small companies that have no EDI capability. The service bureau converts EDI transmissions to fax or paper documents and forwards them to the supplier (and vice versa).
- Real time transmissions of ship notices are receiving wide attention by auto makers. Chrysler has been especially aggressive in setting up an entirely real-time system, using a Tandem computer and software from Mpack EDI Systems (Livonia, MI). Incoming ship notices are checked against material releases and production schedules to insure smooth coordination at the receiving docks. The communication channel between the supplier's computer and Chrysler's computer is kept open until the check is complete. An "accept" or "decline" notice is generated by Chrysler and sent back to the other computer. At the instigation of the AIAG, a subcommittee in ANSI X12 has been created to examine and design transaction sets for real-time EDI.
- Intercompany electronic mail is not used extensively in the auto industry, but does exist and will probably increase in use. Ford submits quality control questionnaires to its suppliers over an E-mail network. The use of E-mail is expected to increase to augment concurrent design programs between principal manufacturers and their subcontractors.
- International EDI connections are of growing interest to manufacturers, as a globalization of the automobile industry has taken place during the 1980s and is expected to develop even more thoroughly in the 1990s. The world's auto makers and leading suppliers are integrating through intricate joint-venture production agreements, cross-ownerships of

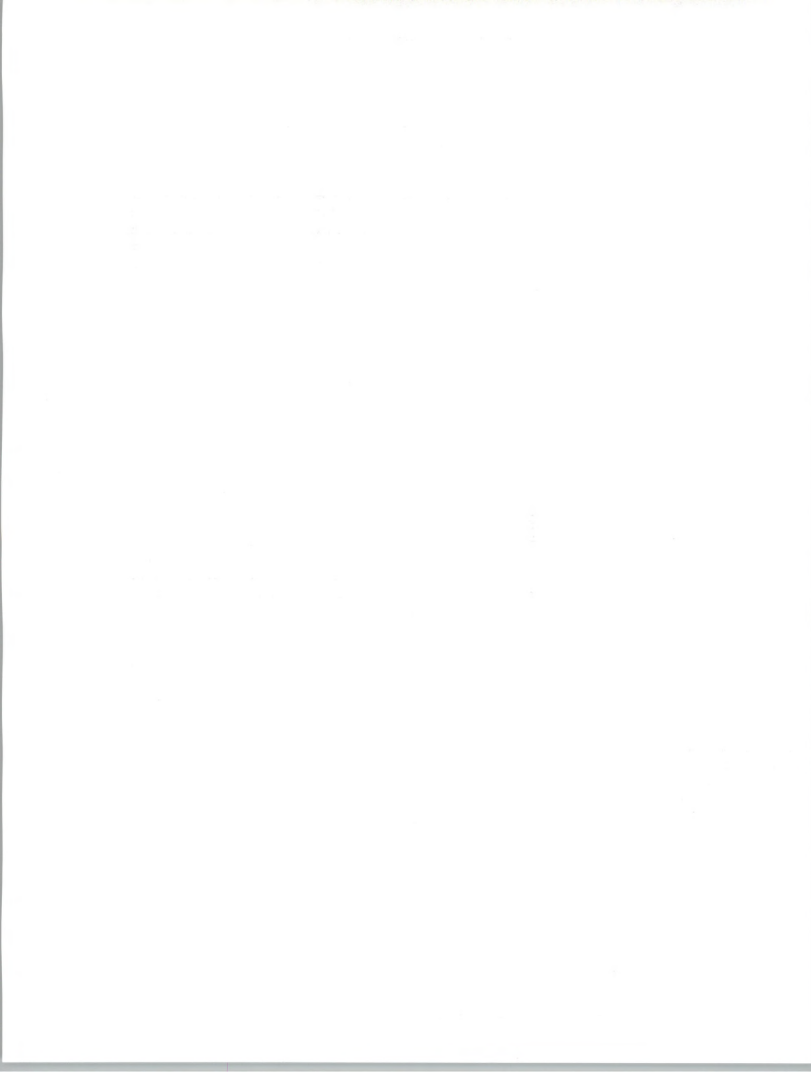

assembly and parts production facilities, and parts outsourcing relationships that cut across national boundaries. In addition, the U.S. big three have wholly owned plants in Mexico, Brazil, South Korea, and Thailand. As U.S. manufacturers increase the degree of global operations, their domestically based suppliers are asking themselves "do we ship product abroad or do we build a plant over there?" Those who choose to ship—frequently the interim solution before a foreign presence can be established—require international EDI connections. Cummins Engine is an example of a company with international EDI requirements.

Exhibit VII-1 quantifies EDI use in the automobile industry.

2. Auto Parts

Auto parts stores and their distributors, wholesalers, repair shops, service stations, and manufacturers are using EDI on both a direct and third-party basis.

Parts stores have large inventory requirements. The ability to serve a particular customer need is a key selling point. Accordingly, rapid delivery from distributors is required, and electronic catalogs are quickly becoming a necessity.

Transnet was one of the first electronic ordering systems. It was started by five companies in the automotive parts after-market but is now operated by the Motor and Equipment Manufacturing Association (MEMA), Englewood Cliffs, NJ, through its for-profit, taxable subsidiary, the Management Information Systems Group. Originally using proprietary formats, Transnet has added ANSI X12 support.

Approximately 135 manufacturers, representing over 80% of the automotive after-market's major product lines, are available through Transnet. Six thousand wholesalers and retailers use Transnet, which is offered free to them.

Among Transnet's users are: AC Delco Division, General Motors, Champion Spark Plug Company, Purolator, Goodyear Tire and Rubber Products, and Timken.



EXHIBIT VII-1

Statistics on EDI in the Auto Industry

Number of EDI users:

	Corporations	Sites
Actual	1,800 (including 15 car/truck manufacturers and suppliers)	3,000
Potential	4,000	6,600

Leading Manufacturers	Principal EDI VANs	Principal EDI Software Vendors
Chrysler	GEIS	Transettlements
Ford	Chrysler	Supply Tech
General Motors	Ford	American Business Computer
Navistar	GE/EDS	Mpact EDI Systems
Paccar	IBM IN	
Mack Truck		
Freightliner		
John Deere		
Caterpillar		
Honda		
Nissan		
Toyota		
Mazda		
Diamond Star (Mitsubishi)		
Volkswagen		

Transaction Volume Benchmark: Chrysler
 9 million kilocharacters sent or received per month in just
 ship notices, schedules, and schedule updates
 (average document size: 40 K)

Source: AIAG

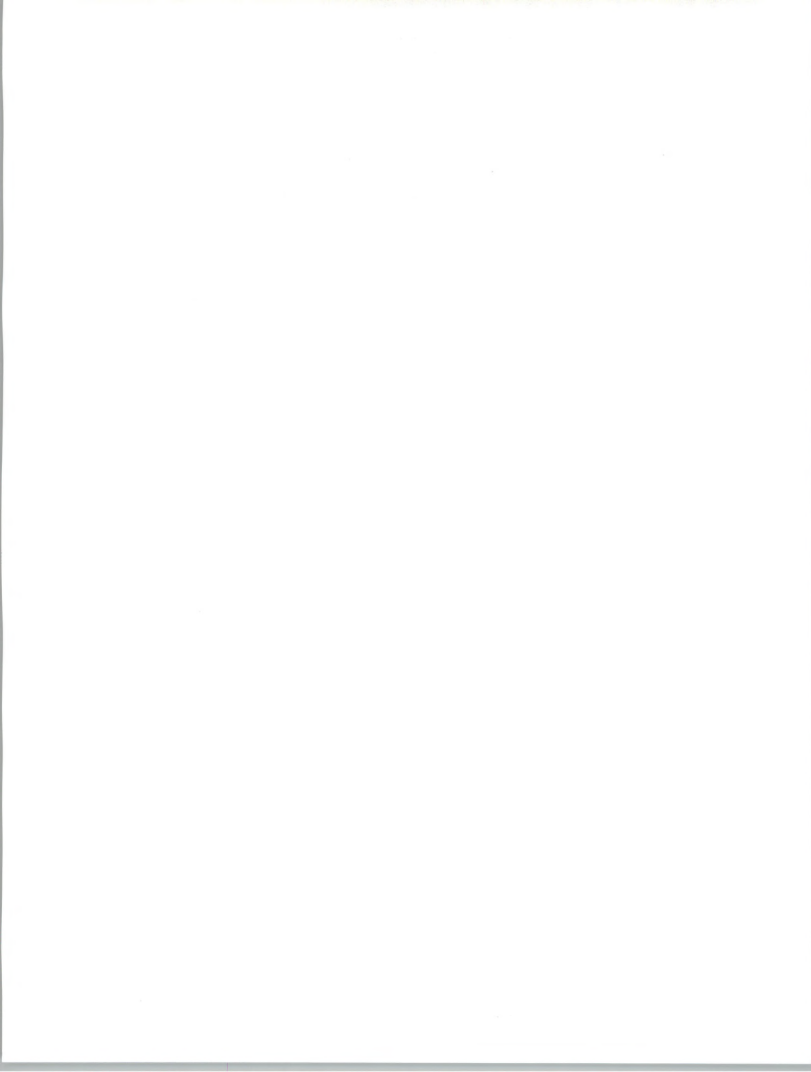

B**Paper, Printing, and Publishing Industries**

There are two primary EDI applications in this trading community:

- The buying and monitoring of paper by publishers.
- The ordering of books by retail and college bookstores.

Exhibit VII-2 depicts the use of EDI in the paper/printing/publishing industry.

EXHIBIT VII-2

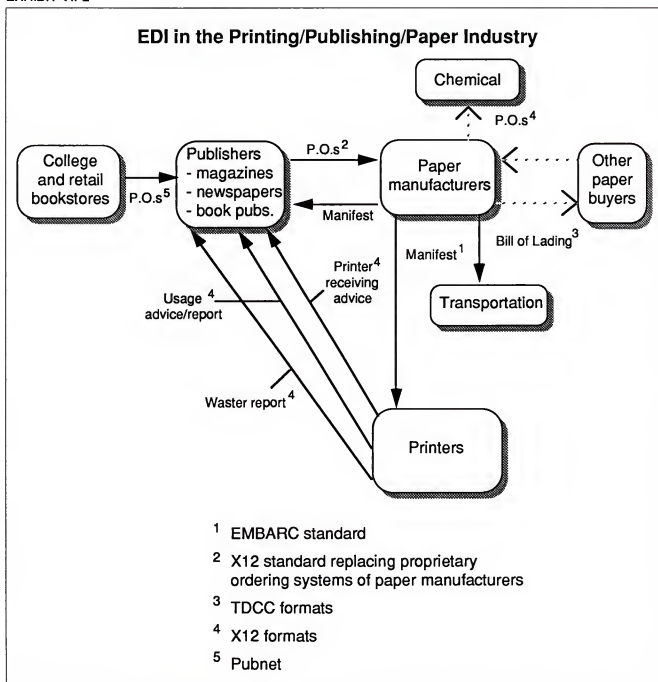

I. Magazine and Newspaper Publishing

A number of EDI efforts are underway in this industry. Newspaper and magazine publishers use EDI with paper manufacturers and independent printers.

Because 50% of the cost of producing a newspaper or a magazine is for paper, the first EDI application in the publishing industry was a document to track paper.

The Electronic Manifest and Bar Code (EMBARC) standard was developed so that publishers, paper manufacturers and printers could electronically communicate the status, quality, quantity, and location of rolls of paper stock.

First, a publisher orders paper stock from a paper manufacturer and instructs the manufacturer to send the paper to a printer (printers are typically independent of the publisher, particularly in the magazine business). When the manufacturer ships the paper, it sends an EMBARC manifest to the publisher and the printer. Bar codes are attached to each roll of paper stock. When the printer receives the paper, it scans the bar codes and matches it with the previously received EMBARC manifest.

The Printing Industries of America designed the EMBARC standard. It is now in the process of designing a complementary standard which it is calling the EMLOOP standard. Unlike the EMBARC standard, it will use X12 formats. It will basically be an X12 Product Transfer transaction set. EMLOOP is the EDI communication from the printer to the publisher which tells how much paper was consumed or wasted on a particular printing job. (The transaction "closes the loop" that started with an order of paper to the paper manufacturer.) The standard will contain two transaction sets: a "Usage Advice/Report" and a "Waste Report." The information will assist publishers in inventory control of the single most expensive element in their production process.

Also, the EMLOOP standard will help determine who pays for wasted paper. In web printing (where paper is threaded through a printing press in one continuous roll), when the web breaks, production costs soar. If the break can be traced to faulty paper quality, the manufacturer pays. If it is the fault of the printer, the printer pays. Otherwise, the publisher picks up the cost. The EMBARC standard contains quality information which is used to trace web breaks back to the manufacturer. The EMLOOP reports on what happened in the production run and therefore who is responsible for the costs of paper consumption.

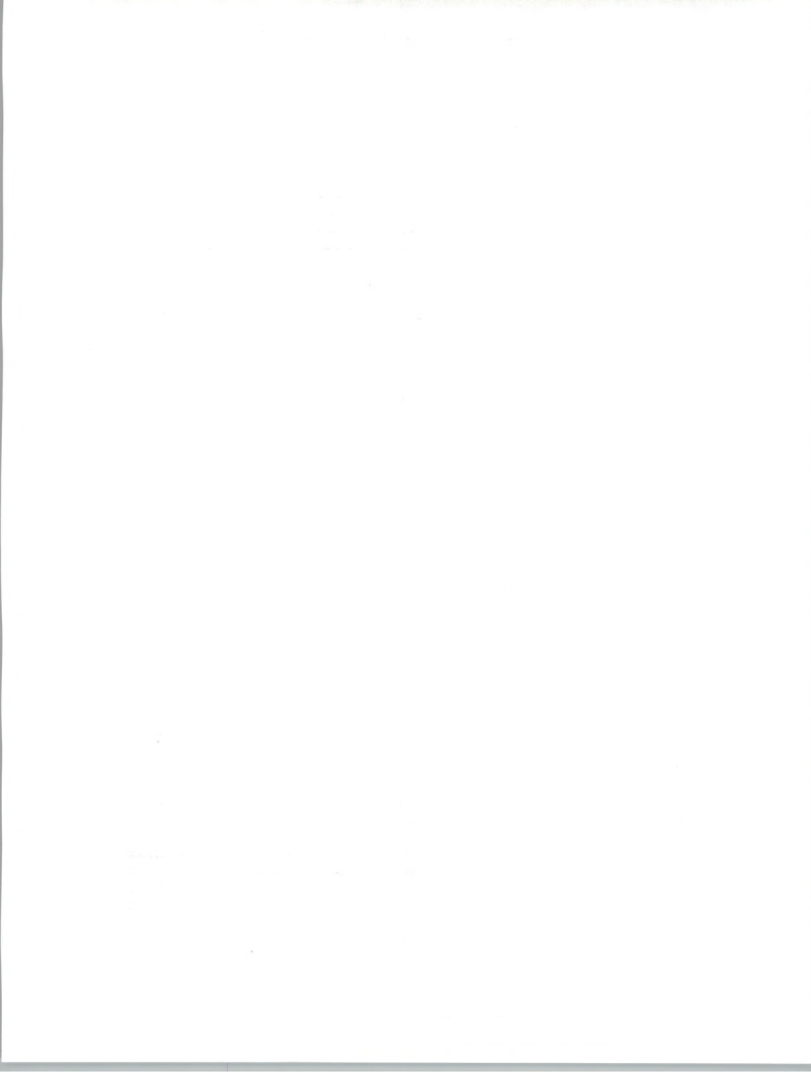

a. Real-Time Needs

The publishing industry intends to increase development of real-time electronic communications between, on the one side, publishers and paper merchants (wholesalers) and, on the other side, paper manufacturers. Real time has been around for some time, as large paper manufacturers have installed proprietary ordering systems with key customers. Real time will continue to be needed as many companies require real-time price quotes, order status inquiries, and stock availability data.

The paper/publishing/printing industry is just now developing purchasing and financial EDI transaction sets. The American Paper Institute (New York) is responsible for these transaction sets, and will use X12 syntax. The paper manifest was chosen over purchasing transaction sets because of the importance of paper to the publishing enterprise.

The American Paper Institute estimates that there are approximately 1,000 printers conducting some kind of EDI with publishers and paper manufacturers. The number of publishers and paper manufacturers combined is only in the low 100s. Leading printers include R.R. Donnelly and Keller; leading paper manufacturers are Georgia-Pacific, Abitibi-Price, and Champion. The leading value-added network servicing the paper and publishing industries is GE Information Services.

2. Book Publishing

Since the early 1980s, book publishers have made various proprietary electronic systems available for bookstores to order books.

Today, the industry is converging on a single standardized system called Pubnet. Managed by the Association of American Publishers, Pubnet runs on the GEIS network.

Pubnet was initially targeted by textbook publishers to college bookstores. But now, with the adoption of Pubnet by the two largest retail book chains (Waldenbooks and B. Dalton), it is becoming a full-line book ordering system.

Pubnet maintains an on-line catalog of 2,500 book titles and their ordering availability. Buyers have the option of ordering on-line or in batch, using ISBN numbers. Book publishers update the book catalog nightly.

Pubnet uses an industry-specific standard for purchase orders, the Book Industry Study Advisory Committee (BISAC) standard. The committee is changing this over to X12 syntax. The X12 syntax allows for variable-length transaction sets, whereas BISAC is of fixed length. Variable length is more flexible and efficient.

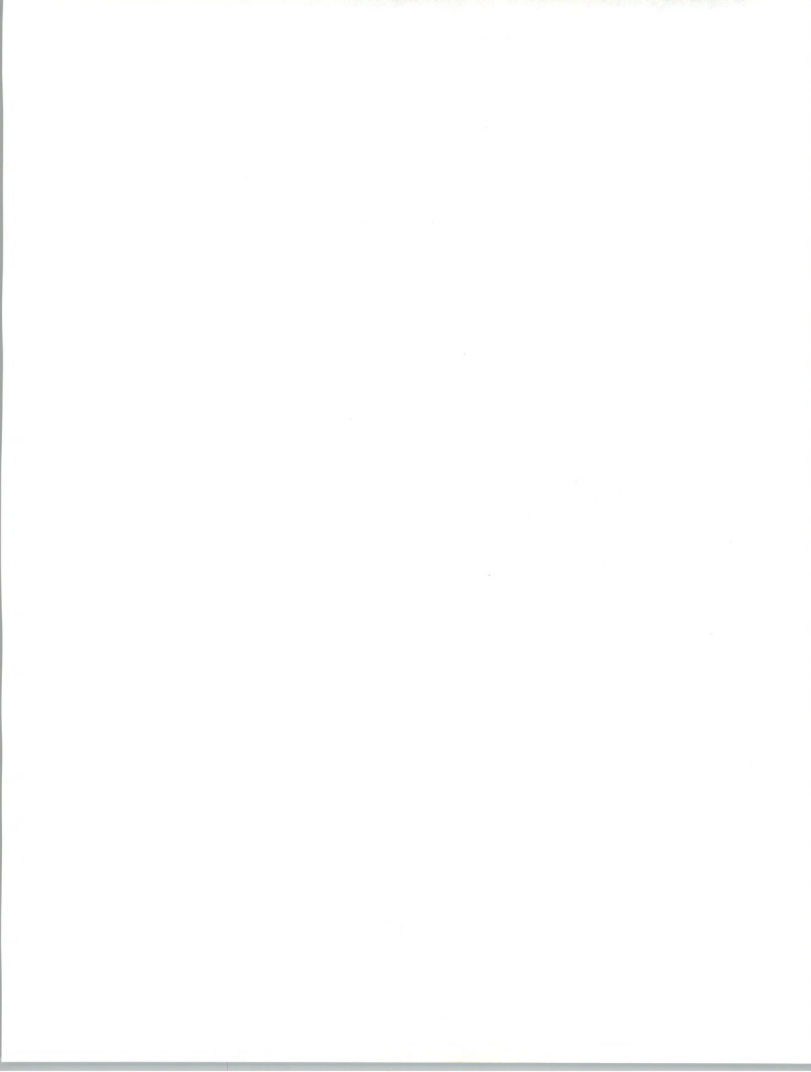

So far, purchase orders are the only working transaction sets. An invoice is under development.

Exhibit VII-3 shows Pubnet's volume.

EXHIBIT VII-3

	1989	1990
Retail and college bookstores	900	2,000
Publishers	25	30
Total	925	2,030

C

Retail, Apparel and Textile Industries

The \$72 billion U.S. apparel industry is growing at roughly three to five percent per year, according to the U.S. Department of Commerce.

Apparel manufacture is a highly labor-intensive business (labor is the largest single cost component). With nondomestic manufacturers supplying roughly half of the apparel products in stores, the U.S. industry is continuing to adopt automation technologies to enhance its competitiveness. EDI is part of this trend.

From a trading partner perspective, apparel manufacturers are situated between their textile mill and accessory suppliers on one hand and their retail establishment customers on the other (see exhibit VII-4).

Leading companies from this cross-industry triad—retail/apparel/textile—have joined to forge EDI transaction standards and implementation guidelines. Several industry groups have been formed for this purpose.

- The Voluntary Interindustry Communications Standards (VICS) is administered by the Uniform Code Council and uses ANSI X12 syntax for the development of EDI standards for the retail, apparel and textile industries. It is composed of representatives from the leading companies in these three industry groups.
- The Textile/Apparel Linkage Council (TALC) has approved a subset of X12 for the industry called Textile Apparel Manufacturer's Communications Standards (TAMCS). As part of its standards development,

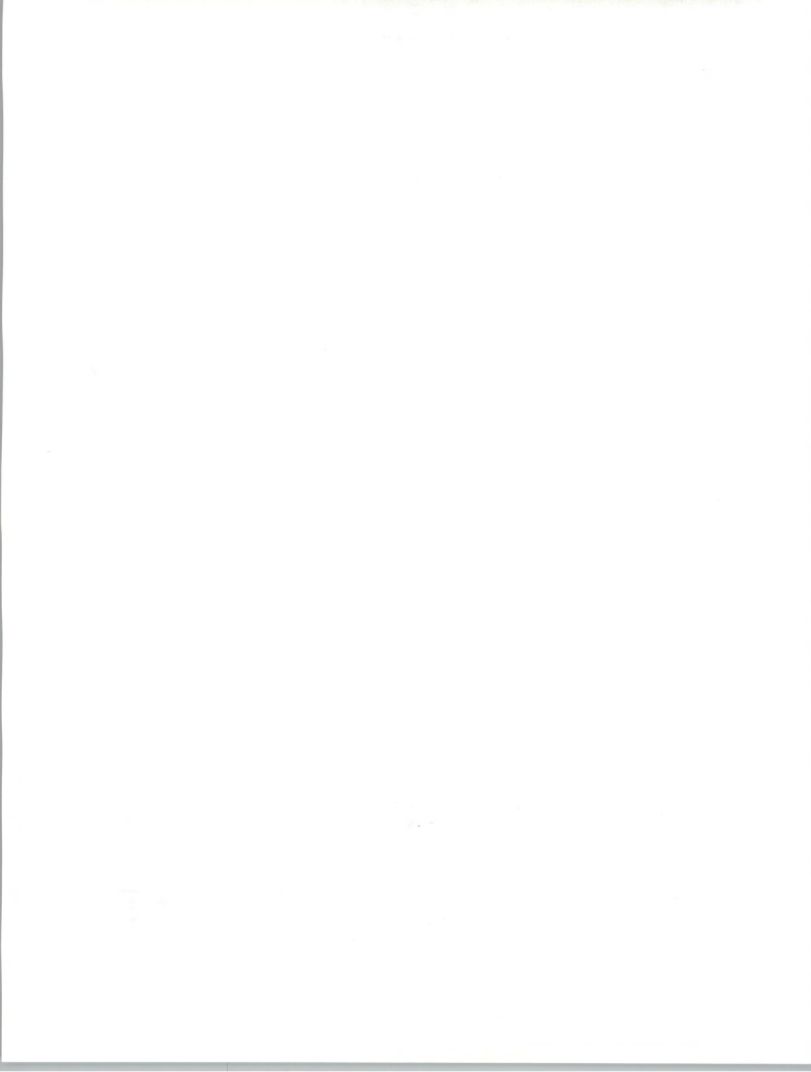
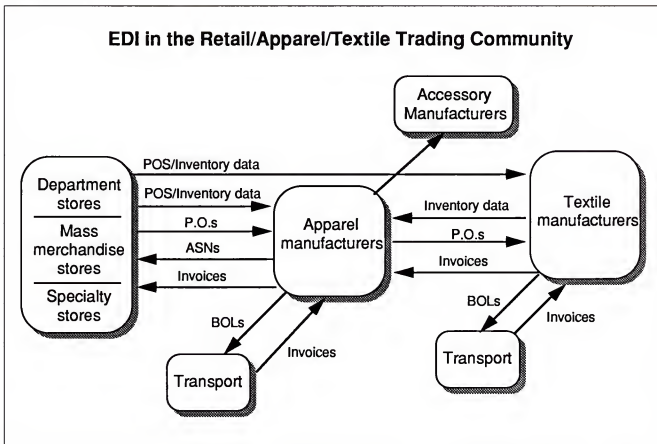

EXHIBIT VII-4



TALC has created data segments for communicating product descriptions about fabrics between cutters and suppliers, covering widths, shading, and other details.

- FASLINC is the Fabric and Supplier Linkage Council, with members in the textile and nonwoven materials industries, suppliers of fiber, dyes, and chemicals, and others. The group is developing standards for EDI as well as other industry-specific needs, to reduce length of order cycles, shipping errors, and inventories.
- SAFLINC is the Sundries and Apparel Findings Linkage Council with members in sundries and findings (ornaments). Its approach to EDI is similar to FASLINC's.
- The Uniform Code Council (UCC) is the agency that establishes bar codes (Uniform Product Codes, or "UPCs") for business entities and their products in the retail, apparel and textile industries (including grocery retail). In the early 1980s, the UCC developed the Uniform Communication Standard (UCS) for the grocery industry to transmit EDI transactions between wholesalers and food manufacturers.



In response to foreign competition and the desire to implement more efficient transaction strategies, particularly quick response, the retail/apparel/textile nexus is implementing EDI in lockstep.

EDI in the retail, apparel and textile industries is the foundation for a distribution strategy called "quick response."

Quick response aims to eliminate the two big threats to any economic system: shortages and oversupplies. Both are costly.

- Shortages result in lost sales.
- Oversupplies, even if eventually sold down the road, are a drain on capital. It has been estimated that 25% of the annual profit potential of the apparel industry is lost due to unplanned retail markdowns. Markdowns are used to liquidate overstocked inventories.

Quick response is a strategy of fine-tuning logistics so that what the consumer (or value-adding vendor) wants is there on the shelf (or assembly line) no sooner nor later than he/she wants it. It is designed for manufacturers to respond almost instantly to the demands of the marketplace.

Because quick response requires close relationships between retailers and manufacturers, it has been lauded as saving the apparel industry from offshore suppliers. Quick response works best when domestically applied, according to industry spokespersons.

- Order turnaround between a U.S. retailer and a U.S. apparel manufacturer using quick response is one to three weeks.
- Order turnaround between a U.S. retailer and a Caribbean-based maker is 17 weeks.
- Order turnaround between a U.S. retailer and an Asian maker can be six months.

Quick response enables retailers to receive a better return on their merchandise inventory, which accounts for 75% of the retailer's capital outlays.

Quick response allows retailers to stock a wider assortment of products in their stores. Store shelf space is constant. Quick response assures the retailer that merchandise can be replenished in days rather than weeks.



- Therefore, instead of stocking large quantities of a few items, the retailer is able to stock small quantities of many different types of items.
- The goal is not to carry less inventory, but rather less inventory per stock-keeping unit.

The VICS organization is spearheading the drive for quick response. Its specific objectives are:

- To have all retailers, apparel and textile manufacturers conduct EDI purchasing.
- To have all apparel manufacturers tag their products with UPC bar codes. The retailer can move the merchandise to the show room floor immediately upon receipt. The resulting point-of-sale data from the scanned bar code feeds back into the retailer's EDI ordering system.
- To have all apparel manufacturers mark the shipping cases in which products are sent with a single bar code (code 128). Retailers scan this code and electronically match the received goods with the purchase order.

If companies perform these practices, commercial transactions between retailers and apparel manufacturers can be entirely automated.

1. Advanced Services

In addition to mainline EDI—purchase orders, invoices, ship notices—leading companies are electronically transmitting data in X12 formats that is helpful to production planning and operations.

- Point-of-sale data from consumer purchases at retail outlets is transmitted back to the apparel manufacturer and in some cases the textile mill that makes the material in the product. The data helps the stores' upstream suppliers detect sales trends which in turn aids in their production planning.
- Sale trend analysis data. Leading apparel manufacturers (Levi Strauss, Playtex) process the point-of-sale data received from the retailer (like consumer goods makers Proctor and Gamble and Gillette are doing). The manufacturer gives the retailer a report of the sales of its specific product relative to the overall sales of the product in the retailer's geographic area. The retailer can compare its performance with the average sales performance of its competitors.

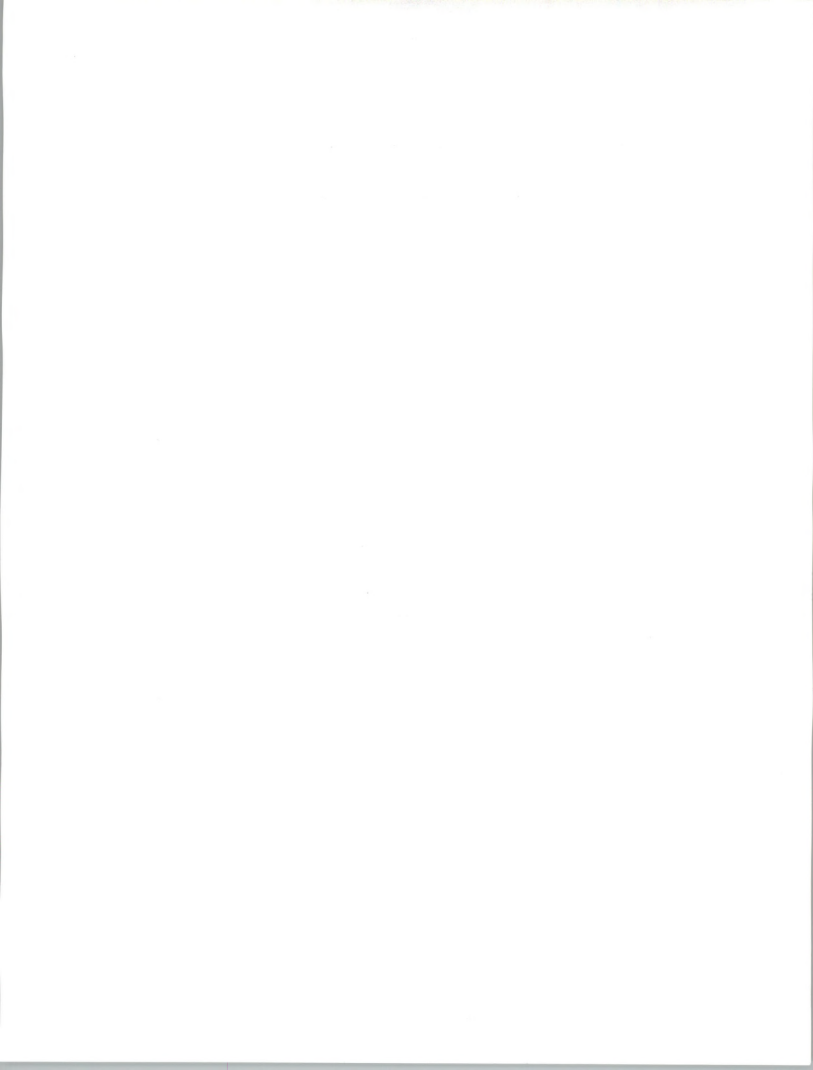

- Inventory data is transmitted from textile and accessory suppliers to apparel manufacturers so that the manufacturers can know what stocks are on hand that can be ordered.

With this advance intelligence on market demand and resource supply, makers can adjust their production plans accordingly.

- Also, apparel manufacturers are aiding retailers—particularly department stores and mass merchandisers—with electronic updates on product catalogs.

An apparel manufacturer uploads an electronic listing of its product line at the stock-keeping unit level (item/size/color) to a product catalog data base maintained by a network service provider (either IBM Information Network or GE Information Services). The listing itemizes each product with an identifying UPC bar code and its corresponding retail price.

A retailer downloads this information and updates its price look-up data base. The data base drives the point-of-sale cash registers in the store. It is referenced every time a sales clerk scans a bar code that is attached to a piece of merchandise.

a. Inventory Modeling

A number of apparel manufacturers (Levi Strauss and Playtex, for example) are offering inventory modeling/automatic replenishment services to their retail customers.

The apparel vendor's sales representatives work with the retailer to review historical ordering data for a specific product and to formulate a mathematical reorder equation. The equation is a function of consumer purchases, the amount of product inventory in the store, and the turn-around time it takes for the vendor to deliver the product to the store. With this data, the equation determines the volume of product to be ordered in a given period.

After the model is developed, the retailer sends the vendor point-of-sales and inventory data using X12 formats. The vendor automatically delivers the quantities.

Automatic replenishment is suitable for standard, nonseasonal, nonfashion products.

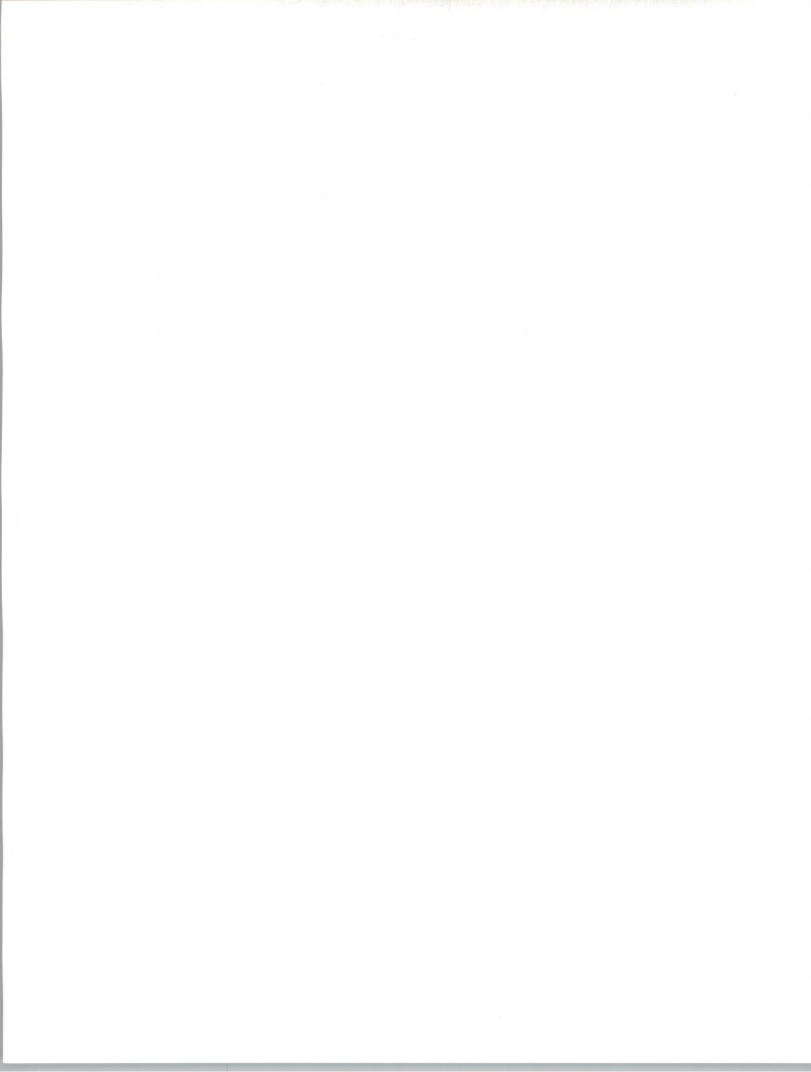

b. Electronic Payments

Electronic payments are still in their infancy in the apparel industry. However, Levi Strauss, in conjunction with First Chicago bank, has implemented an easy-to-use program for retailers to pay Levi Strauss electronically.

c. Real Time

Since it deals with the retail sector, the apparel industry is considering implementing real-time systems.

Retail is distinguished from other industrial and distribution sectors by:

- Highly stochastic consumer behavior
- High volumes of small-quantity purchases

Many leading apparel and retail companies are developing real-time systems between companies and between applications within companies.

The VICS committee has developed quick response transaction sets which are aimed at moving point-of-sale and inventory data for automatic replenishment systems.

These transaction sets, used experimentally at this time, are sent either directly from retailer to vendor or, within a vendor's company, from the order entry application directly into manufacturing applications.

Exhibit VII-5 lists leading players in the retail/apparel/textile EDI trading community.

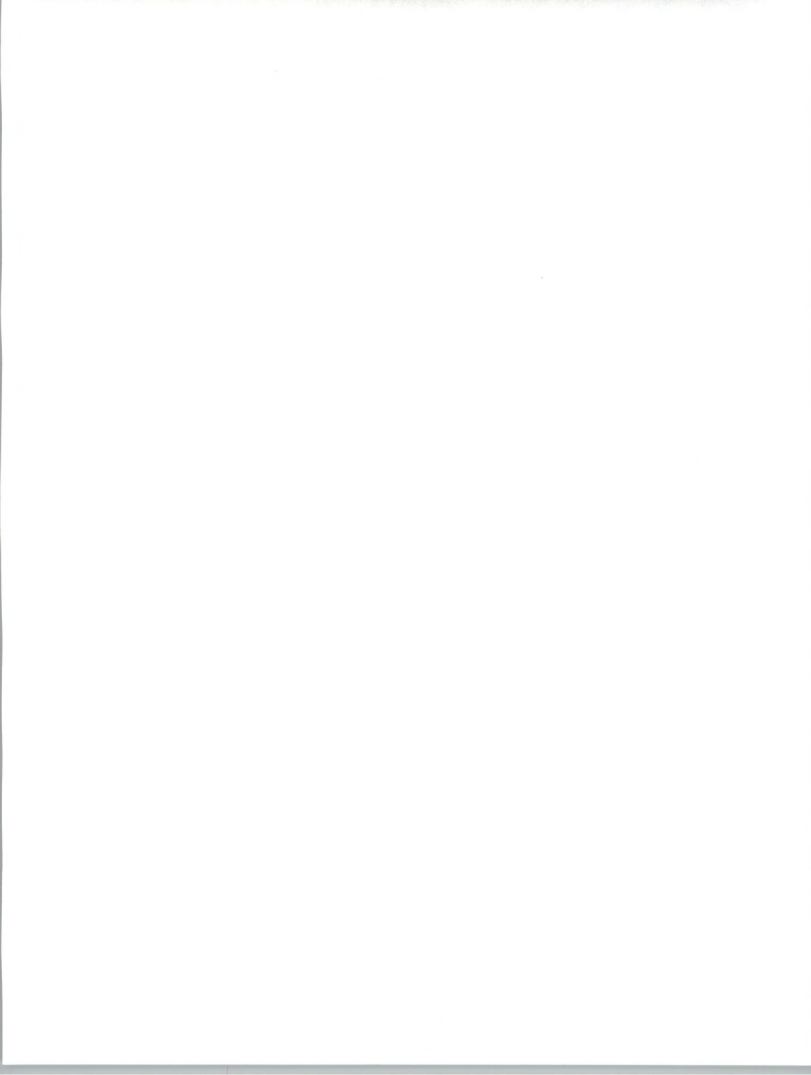

EXHIBIT VII-5

Retail/Apparel/Textile Trading Community Profile

	Retailers	Apparel Mfrs.	Textile Mfrs.
Total EDI Users	100	400	60
Leading Corporations	Wal-Mart K Mart Carter Hawley Hale Mervyn's Dillard's Strawbridge and Clothier	Levi Strauss Hagar Brown Shoe Playtex Liz Claiborne	Milliken Dan River American Hoechst Burlington Industries

Source: UCC/UICS

Leading Network Providers

GEIS

IBM IN

BT Tymnet

D**Hardlines**

Paralleling grocery and apparel in terms of rapid adoption of EDI is the hardlines industry. Here, the EDI connection is between manufacturers of hardwares (tools, home appliances, building supplies, etc.) and distribution entities (hardware stores, home improvement centers, auto parts stores, wholesalers, and distributors).

Approximately 450 hardlines manufacturers conduct EDI with a variety of distribution channels. Approximately 40 specifically hardware/home center retail and wholesale distributors (with a single chain counting as one) are conducting EDI. Other retailers, particularly grocery stores, conduct EDI with hardline manufacturers.

Exhibit VII-6 lists the leading network service providers for the hardlines industry.

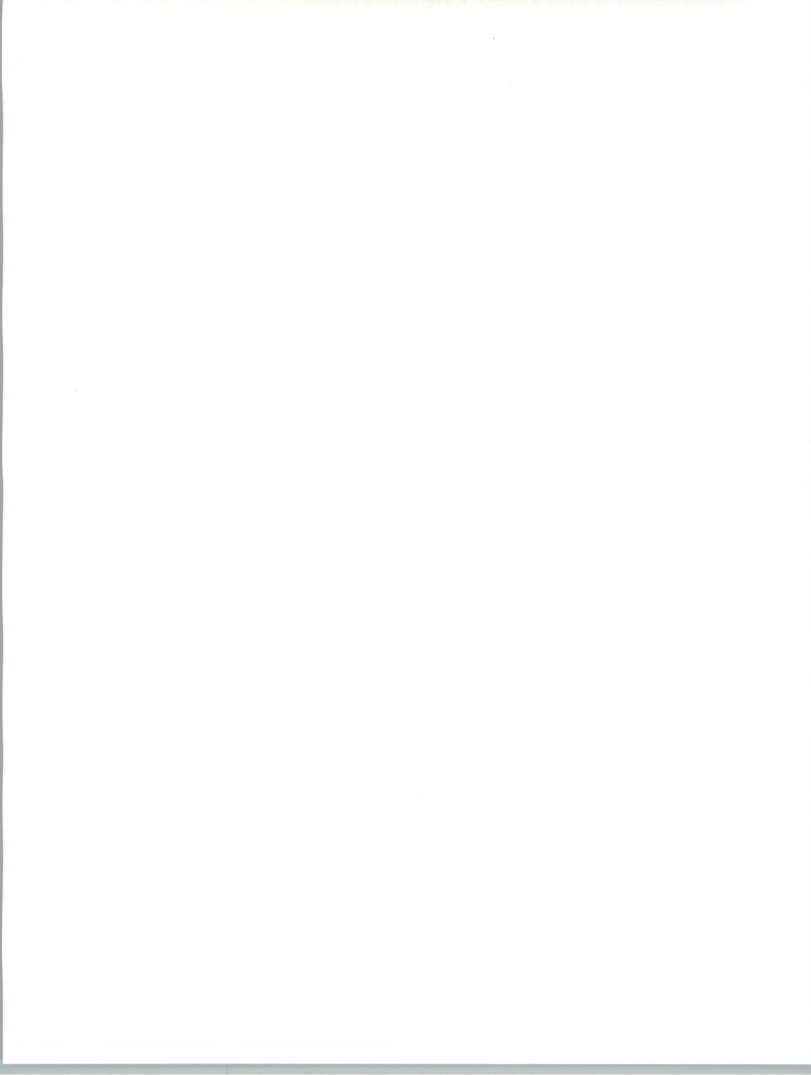

EXHIBIT VII-6

Leading VANs for Hardlines

- Sterling Software/Ordernet
(Eagle network)
- GEIS
- Harbinger
- Transnet
(auto stores)

E**Electrical**

Closely allied to the hardline industry is the electrical supply industry. Leading electrical manufacturers are General Electric and Westinghouse.

The electrical industry sells to many of the same distribution entities found in the hardlines and grocery distribution industries. It also sells to the utility and the construction industries.

The National Electrical Manufacturers Association has established the Electrical Industry Data Exchange (EIDX) committee for companies in the electrical industry to develop X12 EDI standards and implementation guidelines.

A trade group of manufacturers' representatives makes a PC-based software package for applications in order entry and job tracking. It has EDI functionality and is sold to members at cost.

Approximately 110 electrical product and equipment manufacturers use EDI. Approximately 100 electrical supply companies/distributors buy electrical wares via EDI and another 40 or so manufacturing representatives buy via EDI. (Figures are derived from the National Electrical Manufacturers Association and customer lists from network providers.)

Exhibit VII-7 lists leading users and vendors of EDI in the electrical manufacturing industry.

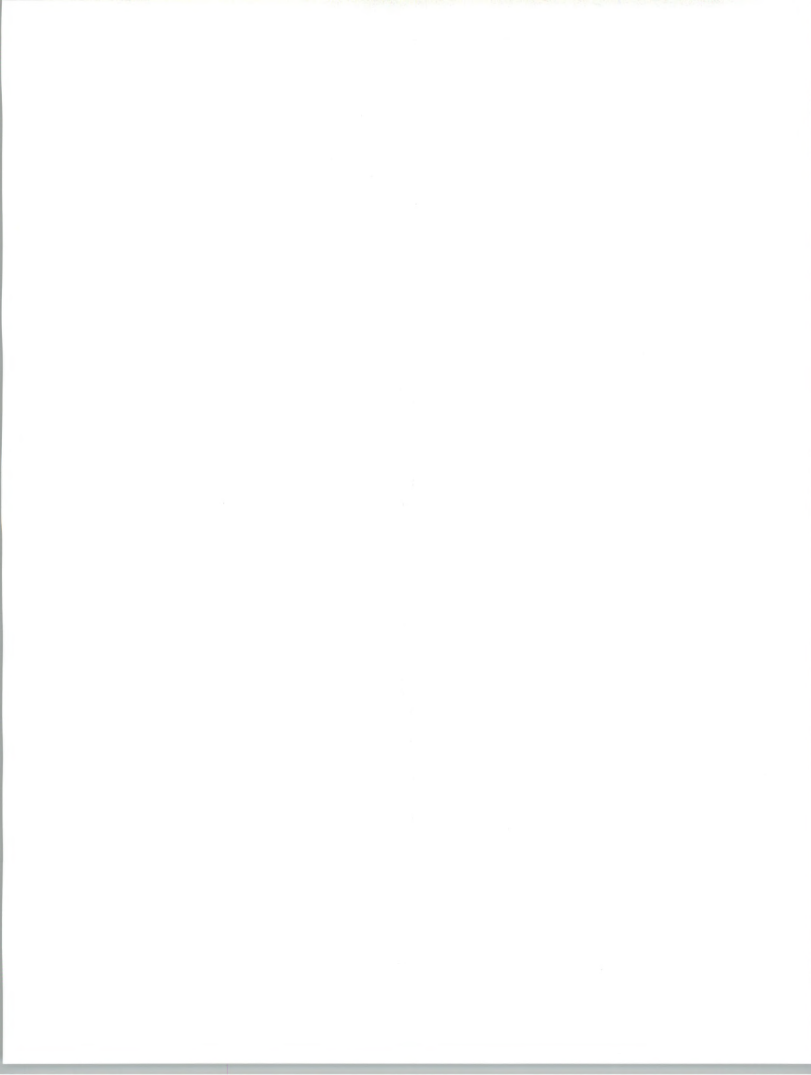

EXHIBIT VII-7

Leading EDI Users and Vendors in the Electrical Manufacturing IndustryLeading users:

- General Electric
- AMP
- Molex
- Westinghouse
- 3M

Leading network service providers:

- Overall volume: Sterling Software/Ordermet
- Total number of company users: GEIS
- Specific to the utility industry: Harbinger

F
Electronics

EDI in the electronics industry is largely confined to makers of semiconductors and electronic components and their customers, either computer and electronic equipment manufacturers or distributors/wholesalers.

Approximately 70 semiconductor/component manufacturers, 60 distributor/wholesalers, and 25 equipment manufacturers use EDI. (These figures are derived from the American Electronics Association and network provider customer lists.)

A large semiconductor manufacturer, such as Motorola or Intel, will have approximately 10 to 30 customers using EDI. These semiconductor makers will also buy supplies from their suppliers using EDI. The suppliers to electronics companies that use EDI (such as office supplies) are examined in other parts of this report.

Relationships in the electronics industry can be quite entangled as companies are often one another's best customers. For example, Digital Equipment is one of Motorola's largest customers as well as one of its largest suppliers—and EDI is used in both directions. Such in-breeding makes it difficult to estimate the size of EDI use in the electronics industry based on numbers of companies alone. Transaction volumes are the ultimate determinants. Unfortunately, such figures are almost impossible to obtain, as users don't necessarily know them and network vendors won't reveal such data.

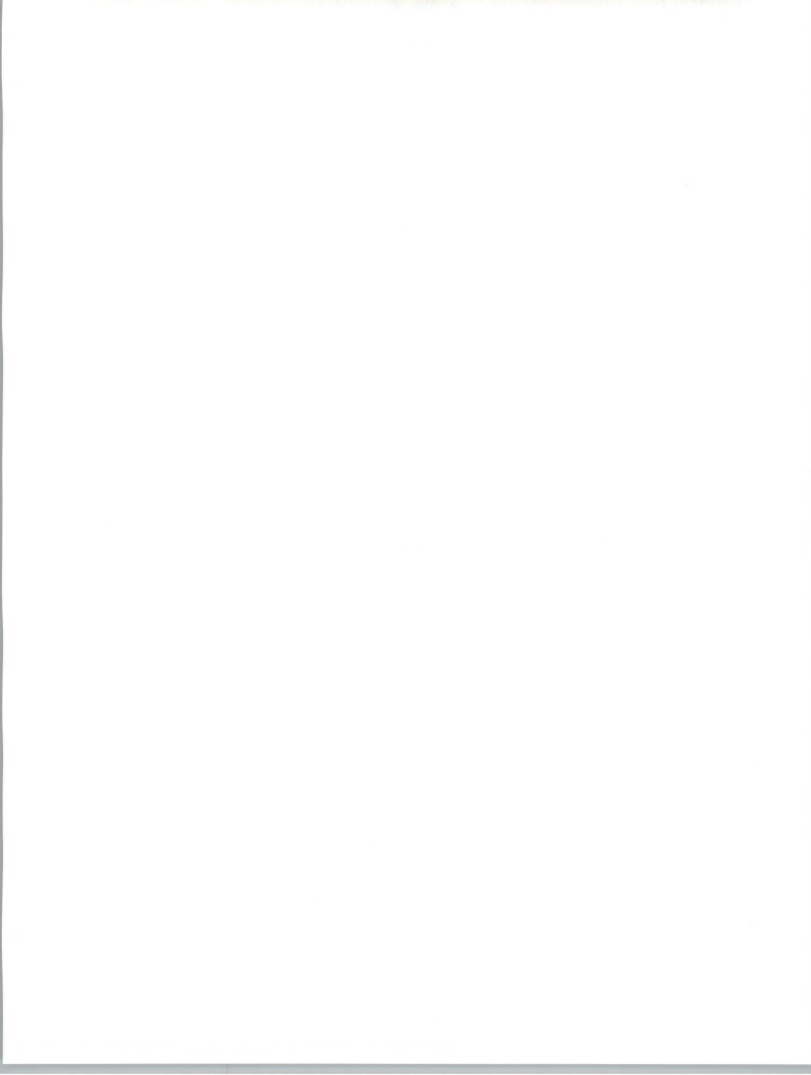

Exhibit VII-8 lists leading EDI users and network providers in electronics manufacturing.

EXHIBIT VII-8

EDI Users and Network Providers in Electronics

Leading EDI Users:

- Semiconductor/Component Makers
 - AMP
 - BULL
 - Digital Equipment
 - Fairchild Semiconductor
 - Harris
 - ITT
 - Intel
 - Mitsubishi Electric America
 - Motorola
 - NEC
 - National Semiconductor
 - Philips
 - Texas Instruments
 - Zenith
 - Toshiba America
- Distributors/Wholesalers
 - Hall-Mark Electronics
 - Hamilton/Avnet Electronics
 - Schweber Electronics
- Leading value-added networks
 - BT Tymnet
 - GEIS
 - Control Data Corp. Redinet
 - Sterling Software/Ordernet

THE UNIVERSITY OF CHICAGO

1954

1955

1956

1957

1958

1959

1960

1961

1962

1963

1964

1965

1966

1967

1968

G**Oil**

U.S. and Canadian petroleum companies are highly integrated. Pipelines literally tie companies together. Drilling operations and properties are jointly owned and operated. Distribution of refined products to retailers is shared among companies constantly swapping each other's supplies to meet the vagaries of daily demand at the gas pump.

Paralleling the product flows are information flows—largely accounting information. Since the mid-1970s, oil company accountants have developed EDI systems for the movement of this data. The systems are collectively called Petrodex, and they are a family of EDI applications which electronically exchange accounting information among companies. GE Information Services is the sole network service provider of Petrodex.

The American Petroleum Institute (API), the Council of Petroleum Accountants Societies (COPAS) and the Petroleum Accountants Society of Canada (PASC) have sponsored the creation of the EDI data formats of Petrodex.

A survey in 1988 by the American Petroleum Institute estimated that the North American petroleum industry would save \$505 million per year by using EDI to facilitate the movement of accounting and other business data among oil companies.

Today, almost 15 different transaction set types are in use by slightly more than 200 leading petroleum companies. More transaction sets are on the drawing boards.

Four of the Petrodex applications keep track of oil and natural gas swaps between companies.

- Petroex provides details on oil product swaps. Truckers who supply service stations pull oil supplies from the terminals of various oil companies. Petroex checks the truck driver's authorization and keeps track of how much the driver took.
- Recon automatically reconciles Petroex swaps, debiting and/or crediting a company and showing its net position relative to other oil companies with which it has a swap relationship.
- Terminal Administration and Billing System (TABS) allows oil companies to set the allowable amount a trucker can pull from a trading partner's terminal under an oil swap agreement.
- Crude-Net allows oil companies to exchange remittance and invoice details on purchases of crude oil among companies.



Three other Petrodex applications monitor oil and gas pipeline uses.

- Gas*Trac allows companies to reserve and schedule pipeline services for the transport of natural gas.
- Pipenet performs the same function as Gas*Trac but for oil products.
- Gas Revenue Accounting Data Exchange (GRADE) allows companies to move payment data related to Gas*Trac exchanges.

Three applications serve the mainstream EDI functions of sending invoices, purchase orders, and funds transfers.

- Joint Interest Billing Exchange (JIBE) is used for moving expense bills. In jointly undertaken exploration and operation efforts, the designated operator company sends these electronic bills to its partners to get reimbursed for the expenses it has paid on behalf of the consortium.
- Joint Audit Data Exchange (JADE) allows the exchange (currently on diskettes only) of data required for joint-interest auditing. It helps reduce the time an operator's audit coordinator spends preparing and assisting joint venture auditors.
- Purchase orders (the ANSI X12 850) is used to buy equipment and supplies.

A variety of other EDI applications serve other functions:

- Geologic Data Exchange allows the transmission of more than 1,000 types of geological data as it is being collected at drilling sites. It helps companies prepare three-dimensional maps of the Earth's mantle, the ultimate objective being to predict where oil deposits lie.
- Check Stub Data Exchange (CDEX) provides owners of oil-producing properties with sales and production data so that they can calculate royalty credits.

Other applications are designed with the following advanced EDI services in mind:

1. Real-Time EDI

- Well Logging Information is sent from the drilling site to oil company operational management offices. Data such as bit torque, mud/fluid properties and drill pressures are relayed to control rooms for real-time monitoring of drilling activity. The results are standardized to facilitate sending the data to multiple owners of oil wells.

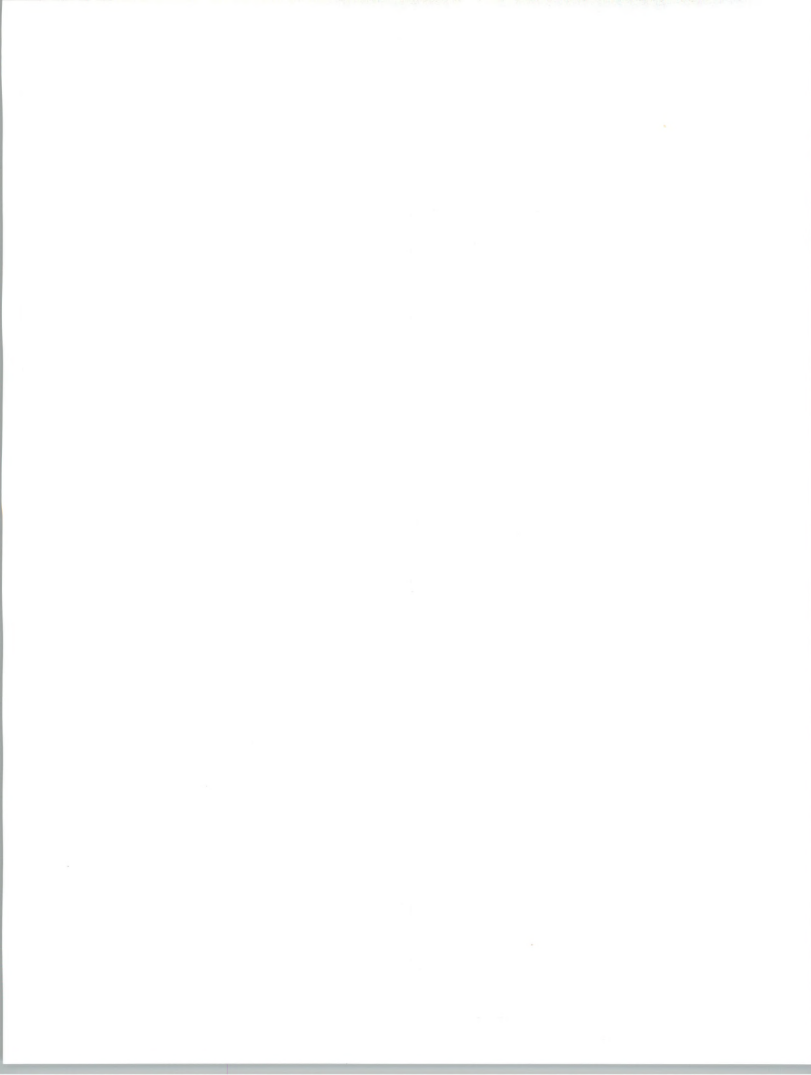

2. Data Bases

- Computerized Equipment Pricing System (CEPS) is a data base for the pricing of frequently used oil field equipment and material. It provides pricing for tubular and equipment items, and rail and truck tariff rates. It contains more than 25,000 date-sensitive price records dating from February 1983.
- COPPE allows refiners and crude-oil producers to post product prices electronically.

3. Electronic Funds Transfer

- Petroleum Treasury Advisory Group (PTAG) are customizing the ANSI X12 820 payment instruction/remittance advice to allow oil companies to pay each other.

Exhibit VII-9 profiles EDI use in the oil industry.

EXHIBIT VII-9

Oil Industry EDI Profile	
Number of Users	200+
Company Types	Oil companies Pipeline companies Drilling contractors Equipment vendors
Sole Network Provider	Petrodex (GEIS)

Source: Petrodex

H

Grocery Industry

The grocery trading community consists of food manufacturers (such as Pillsbury, General Mills, Nabisco, etc.) and business entities involved in distribution (brokers, wholesalers, distributors, buying groups, retailers, and eating and drinking establishments).

EDI activity in this community as indicated on the Input-Output Matrix is largely concentrated on food manufacturers and grocery wholesalers/distributors. Some new efforts are underway between manufacturers and buying groups for restaurants and hotel chains.

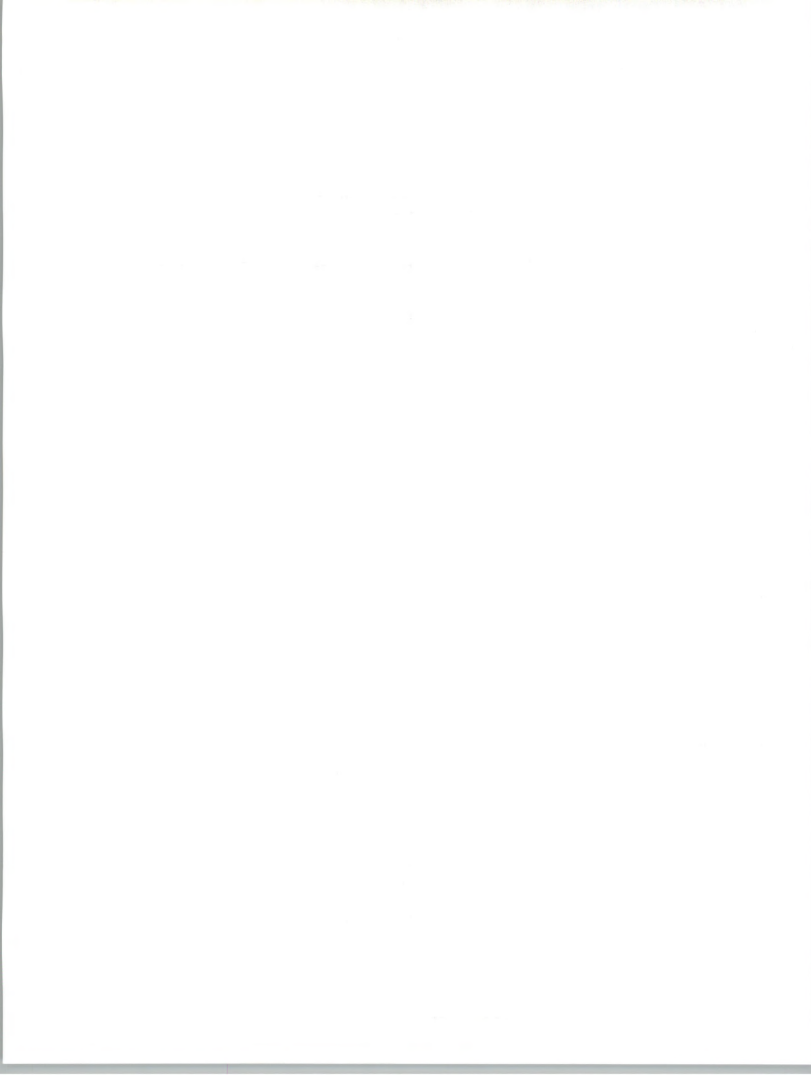

- The increasing transaction traffic in the food distribution business is fueled in part by growth of the industry overall and by growth in the number of food items.
- Total retail sales for all food stores in the U.S. was \$354 billion in 1989 and is expected to rise 7.5% to \$380 billion in 1990, according to the Department of Commerce.
- Between 1979 and 1989, the number of items stocked by the typical grocery store doubled to 26,000.

According to the Department of Commerce, food industry buyers will issue approximately 18 million purchase orders in 1990, up 16% since 1980. These documents trigger a like number of bills of lading and invoices, along with other documents such as adjustments, product announcements, allowances, and other information.

The food industry consists of approximately 5,000 manufacturers and 4,000 entities involved in distribution (including supermarket chains).

Exhibit VII-10 depicts the transactional structure of the grocery industry.

EXHIBIT VII-10

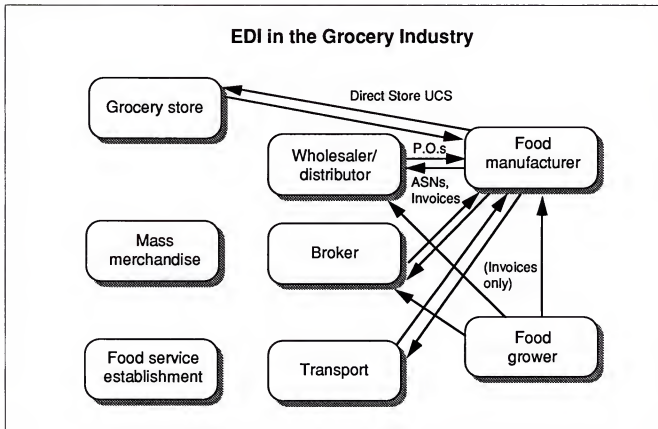

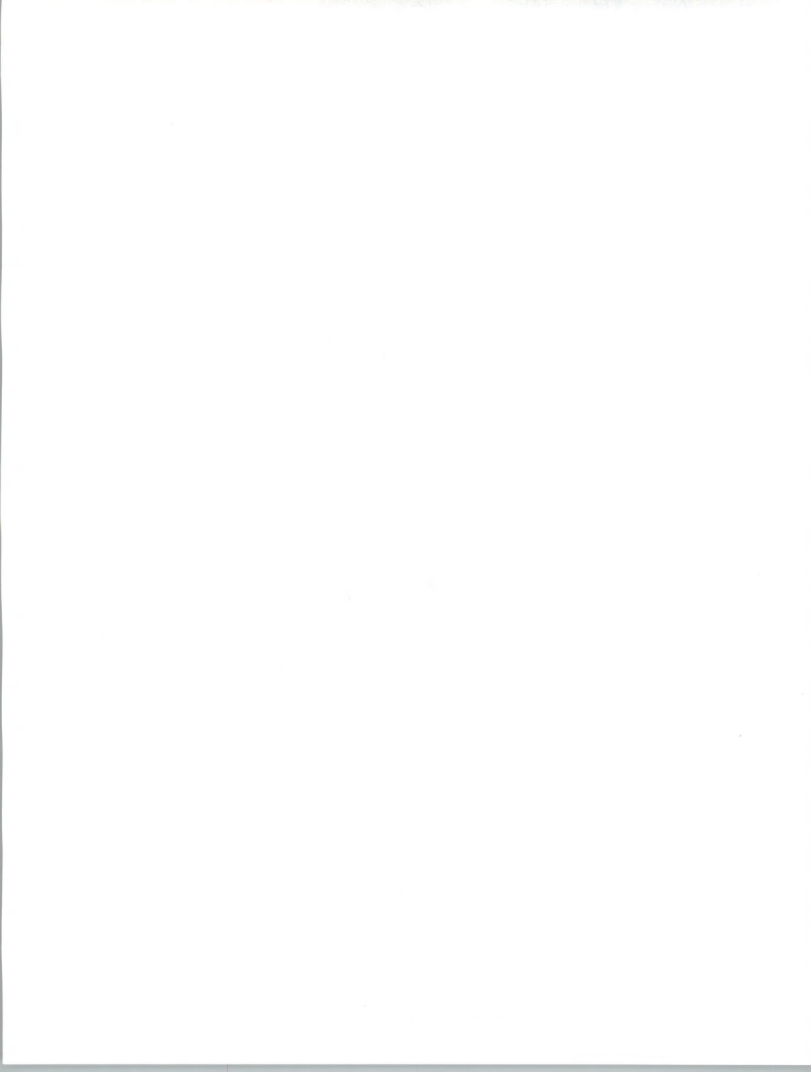

Grocery companies have been adopting EDI since Arthur D. Little calculated in 1981 that the industry could save between \$196 million and \$324 million if only half of all transactions were done electronically.

The Uniform Product Council, the agency behind adoption of bar code standards, assumed the responsibility of coordinating grocery industry EDI through its Uniform Code Council (UCC).

- The UCC created the Uniform Communications Standard (UCS) for use in the grocery industry, which, like the TDCC standards on which they are based, predate the formation of the X12 standards committee.
- Users of the UCS consistently rate it highly.
- Companies participating in the UCS buy communications identifications for a one-time charge ranging between \$500 and \$10,000, based on the company's annual revenues.
- In 1990, the UCS had 529 corporate members and an additional 151 "subsidiary" members. (A corporation can sign up its subsidiaries and/or divisions at a reduced rate.) Membership is up 62% since 1987.

UCS corporate members include 188 manufacturers, 241 brokers, and 100 other businesses such as distributor/wholesaler/retailer/buying group.

Consisting of a web of distribution points, the number of companies that use EDI in the grocery industry is one-fifth the total number of locations that are EDI active. For example, Wal-Mart, a mass merchandiser that buys grocery products, represents 150 separate locations that can be counted as EDI trading partners.

Grocery store products can be classified into the following categories: meat and poultry, dairy, produce, packaged goods, beauty products, and dry goods. The predominant use of EDI in the grocery industry is for the purchase of packaged foods (canned soup, cereal, cake mix, etc.) by grocery wholesalers/brokers from manufacturers.

This practice of EDI, which began in the early 1980s, uses third-party networks and is sometimes referred to as the Network Exchange of UCS data, or NEX/UCS.

The second area of the grocery business in which EDI is being applied is direct store deliverables. In direct store delivery, a manufacturer delivers its product directly to the retail outlet (for example, Frito-Lay delivery trucks deliver snack items to stores on a weekly or semi-weekly basis).



Direct store EDI, begun in 1986, exchanges transaction data at the store site between, typically, a handheld computer device of the delivery clerk and the store's computer system. Direct store deliveries are responsible for approximately 20% of a grocery store's inventory.

This EDI method, called direct exchange of UCS data or DEX/UCS, is still underutilized due to manufacturers' slowness in automating their delivery forces. However, UCC DEX/UCS standards are available for use.

EDI purchases of produce products will probably never occur. Telephone ordering will remain the de facto method. The highly perishable product requires swift hand-offs from grower to distributor to customer. Since supply and demand fluctuate daily, prices need to be negotiated in real time. However, some leading growers are beginning to invoice buyers using EDI.

Bud of California (Salinas, CA) is the largest grower/distributor of fresh fruits and vegetables in the United States. With farms in California and Arizona, the \$300 million (annual sales) company supplies grocery wholesalers throughout the country and overseas.

- In mid-1990, it began sending invoices to its largest customer, Super Valu Foods (Eden Prairie, MI). It sends the invoices twice a week in large batches.
- All Super Valu and other customer purchases come over the phone.
- Every morning, Bud of California harvest foremen (who supervise field workers) estimate the day's harvest for the field that they are responsible for. The estimates are keyed into a data base.
- When customers place orders with Bud sales reps, the reps check the data base. Over the phone they determine quantities and prices for each produce item. Bud truckers call in to tell clerks when they are departing with a delivery. The clerks update the data base.

EDI for produce is illustrative of the "upper limits" of EDI in the economy as a whole. The purchase of raw materials is often not conducive to EDI. For highly perishable commodities, the real-time nature of the telephone is necessary. For other commodities such as coal, purchases are usually made in large bulk orders and the EDI application is typically material releases against blanket purchase orders.

Mass merchandise outlets also buy products classified as grocery and are therefore another trading partner to the grocery industry.

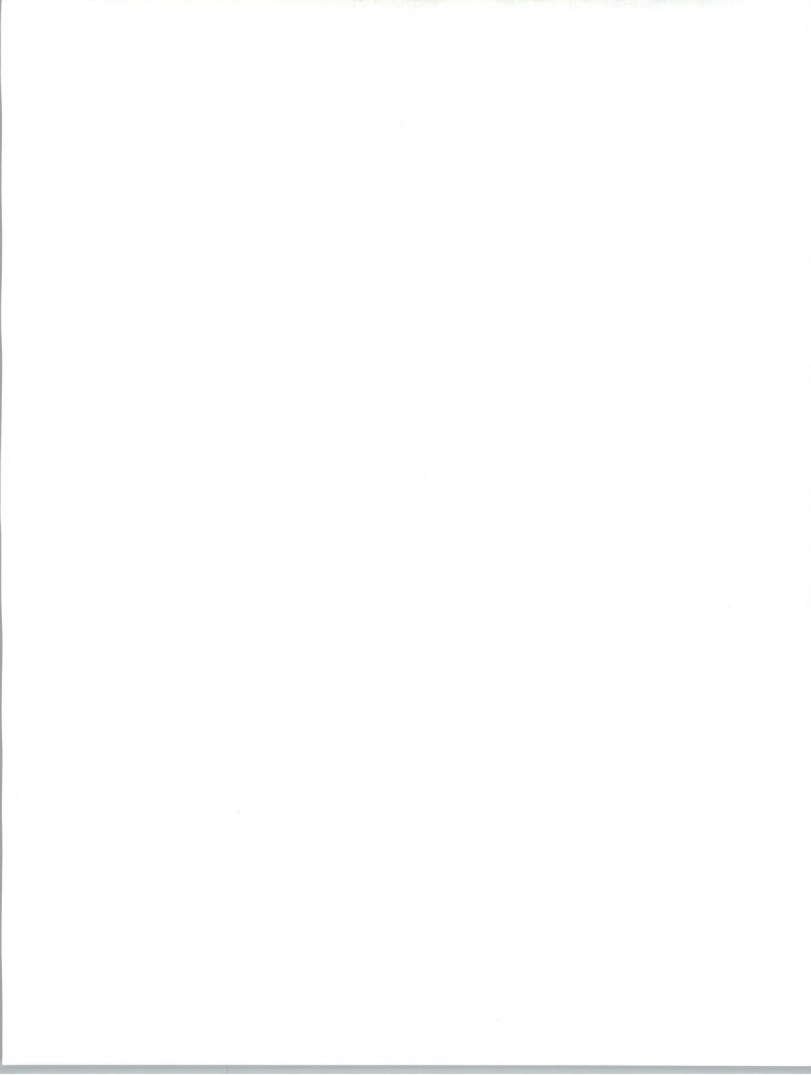

Fast food restaurants and hotels use EDI, largely to buy office supplies, transport, and power, but are beginning to use it to purchase food items. Kentucky Fried Chicken and Pizza Hut (both units of PepsiCo) are doing this.

Tartan Foods (Philadelphia, PA) is a food services buying group that sells food supplies to hotels and restaurants. It conducts some transactions with customers using EDI.

A.R.A. Services (Philadelphia, PA), a multiproduct line food and service company and leading vending machine provider, is considering using EDI to facilitate transactions with its suppliers.

The connecting of grocery manufacturers with food service establishments/businesses (restaurants, hotels, vending machine operators) using EDI is negligible, but some food service brokers are making efforts in this direction. Direct store EDI and real-time ordering systems may be more suitable for the food service sector than network store-and-forward EDI systems. In any event, EDI in the food service sector is ripe for rapid development.

1. Electronic Payments

The low margins and high inventory costs of retail food distribution make retailers leary of electronic payments. However, stores have adopted point-of-sale (POS) debiting capabilities for consumers.

2. Data Bases

The use of a Uniform Product Code data base for grocery products has not been proposed (as it has for apparel products).

Stores are experimenting with consumer purchase tracking systems. Data on individual consumer purchases are captured and sold to food manufacturers who use the data for target marketing.

Citicorp is building a "national household purchase data base" covering 40 million households (half the homes of the U.S.) with information gathered from 12,000 retail stores.

Although this is not directly an EDI application, in time EDI may play a role here.

This topic is covered further in the INPUT study, *EDI: Business Integration Issues*.



3. Real-Time Systems

Some large food manufacturers maintain on-line ordering and order query systems especially for brokers. Nabisco, for example, has a proprietary Broker Support System that runs on its mainframe.

Exhibit VII-11 lists statistics on EDI usage in the grocery trading community.

EXHIBIT VII-11

Grocery EDI Profile

Company Type	Members of the Uniform Code Council		No. of Grocery Industry VAN Subscribers
	Corporate	Subsidiary	
Manufacturers	188	72	341
Brokers	241	29	245
Wholesalers	43	17	75
Retailers	45	32 chains	65
Distributors, buying groups, catalog providers	12	10	9
Total	529	160	735

Source: UCC, EDI Spread the Word

	Summary
Manufacturers	200
Wholesalers/distributors/brokers	400
Total No. of Addresses	2,500
Leading VANs	BT Tymnet Ordernet IBM IN

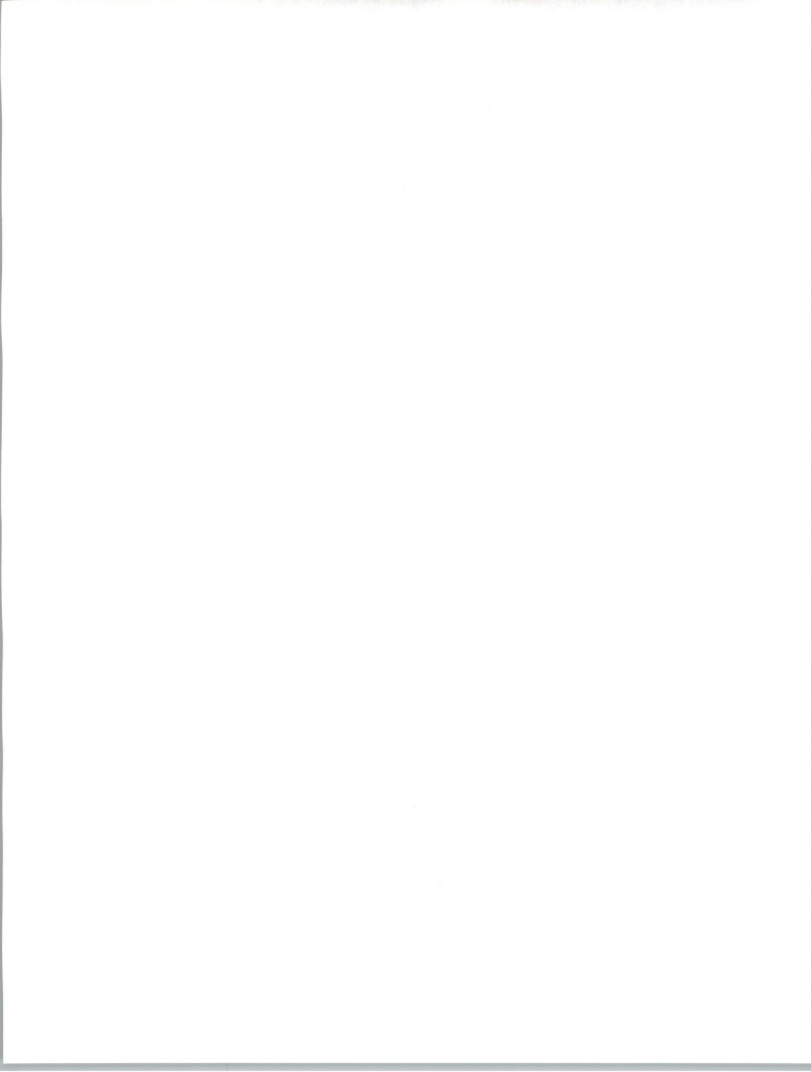

I**Chemicals**

The chemical and allied products industry is one of the largest U.S. industries. The industry produces more than 50,000 different chemicals and formulations in more than 12,000 U.S. chemical plants. Employing about 1 million people and consistently maintaining a positive trade balance internationally, the chemical industry is a core sector of the U.S. economy.

The chemical industry covers inorganic and organic chemicals, and produces and/or provides inputs for the production of industrial gases and pigments; plastic resins and synthetic rubber; drugs and pharmaceuticals; soaps, detergents, and cosmetics; paints and coatings; agricultural chemicals, including fertilizers and pesticides; adhesives and sealants; explosives; printing inks; and a variety of miscellaneous chemicals.

With such a diversified trading partner base, chemical manufacturing can be considered a "hub" industry, much like transportation. Furthermore, its global scale of operations requires it to conduct inter- and intraindustry transactions internationally.

Exhibit VII-12 illustrates chemical industry ties via EDI with many other industries.

These circumstances have important implications for vendors and chemical industry users of EDI products and services.

- For vendors of EDI software and network services, the chemical industry represents a critical vertical market in which to capture market share. Its central position to other industries and its worldwide trading partner base mark it as a dense, "transactionally intensive" market niche.
- For chemical companies, the installation of an EDI system is a development expense that can be leveraged/amortized across many trading partner relationships. The potentially huge scale of EDI use by a chemical company insures that the investment in an EDI system will have a high return. The use of the EDI system has an increasing return to scale (i.e., per-use cost goes down the more the EDI system is used).

INPUT estimates that the use of EDI by chemical companies, although it has grown quickly since 1988, is still well below its potential.

Already, EDI is firmly established in the chemical industry with trading partners in the automobile, transportation, and textile industries, and with other chemical manufacturers (chemical companies tend to specialize).

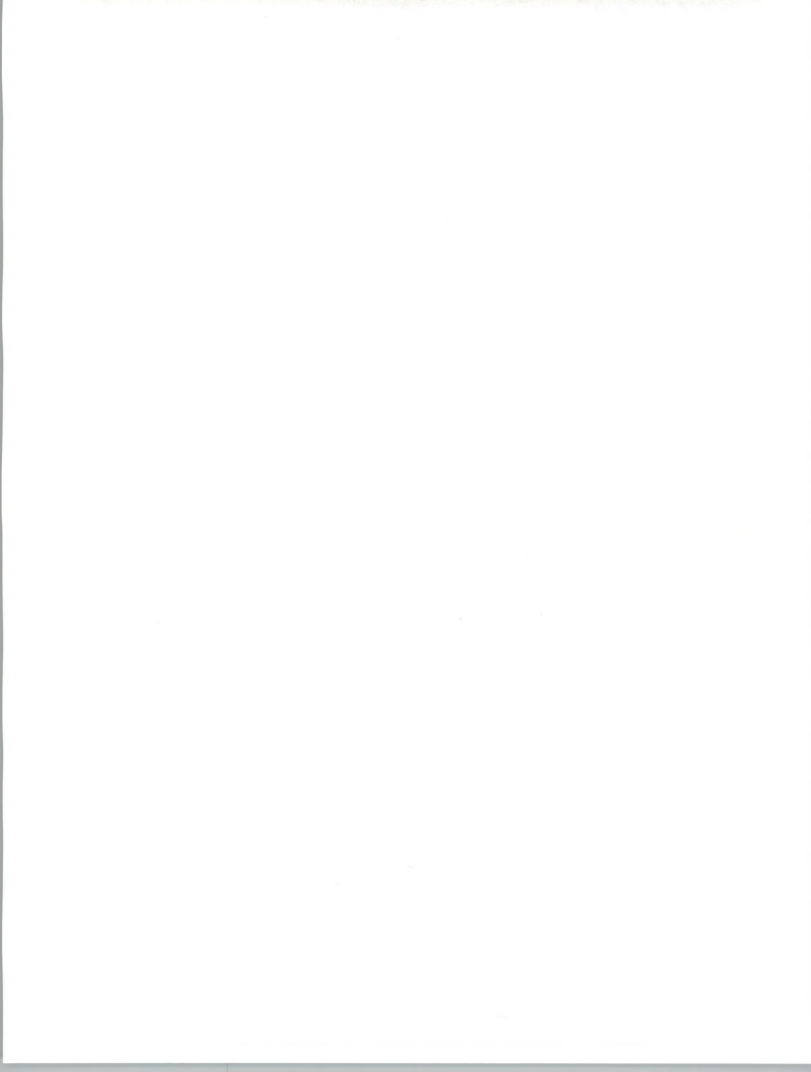
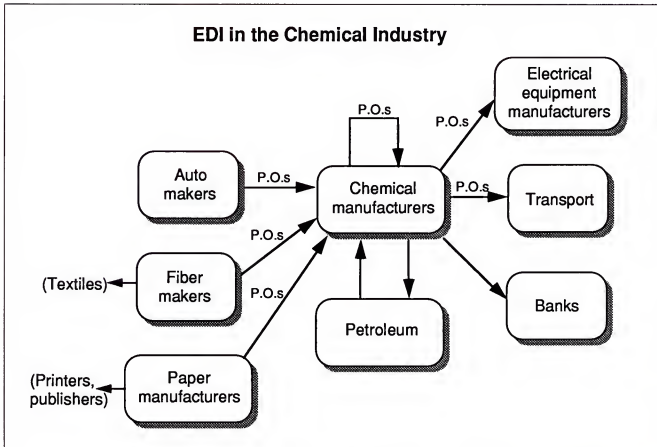

EXHIBIT VII-12



In an average month in 1989, chemical companies sent 65,000 freight invoices and received 119,400. About 15,000 freight status reports were sent and 157,000 received, and 4,350 bills of lading were transmitted, according to a survey by the Chemical Industry Data Exchange.

To a lesser extent, EDI is used by chemical companies with trading partners in the petroleum, pharmaceutical, hard goods, electrical spare parts, paper, and banking industries.

Altogether, purchase orders sent and received in 1989 by chemical industry trading partners other than transportation carriers totalled 14,540 and 10,190, respectively.

INPUT believes that the petroleum, pharmaceutical, and hard goods industries, as well as the paper and wood and food processing industries, are ripe for developing EDI ties to the chemical industry.



The chemical industry's international scale of operations has led to adoption of electronic trading, an important aspect of industry development. Chemical companies were some of the first to experiment with the international EDI standard, EDIFACT.

Additionally, the competitive nature of the global chemical industry, as well as government requirements and demands from customers, have encouraged this sector to improve efficiency by applying information technologies.

Exhibit VII-13 contains statistics on EDI use in the chemical industry.

EXHIBIT VII-13

EDI Use in the Chemical Industry

	1988	1989	Percent Change
Number of chemical companies using EDI:	40	60	50
Number of trading partnerships with chemical industry:	800	2,600	225
Average annual transaction set volume	1.68 (M)	5.4 (M)	225
Total value of shipments for chemical industry	\$258.9 (B)	\$274.5 (B)	6
Real growth	2.1%	3.2%	
U. S. trade surpluses	\$12 (B)	\$15 (B)	25

Source: CIDX, Dept. of Commerce

Leading networks: BT Tymnet, Kleinschmidt (car location messages), GEIS

Transaction sets available: 25

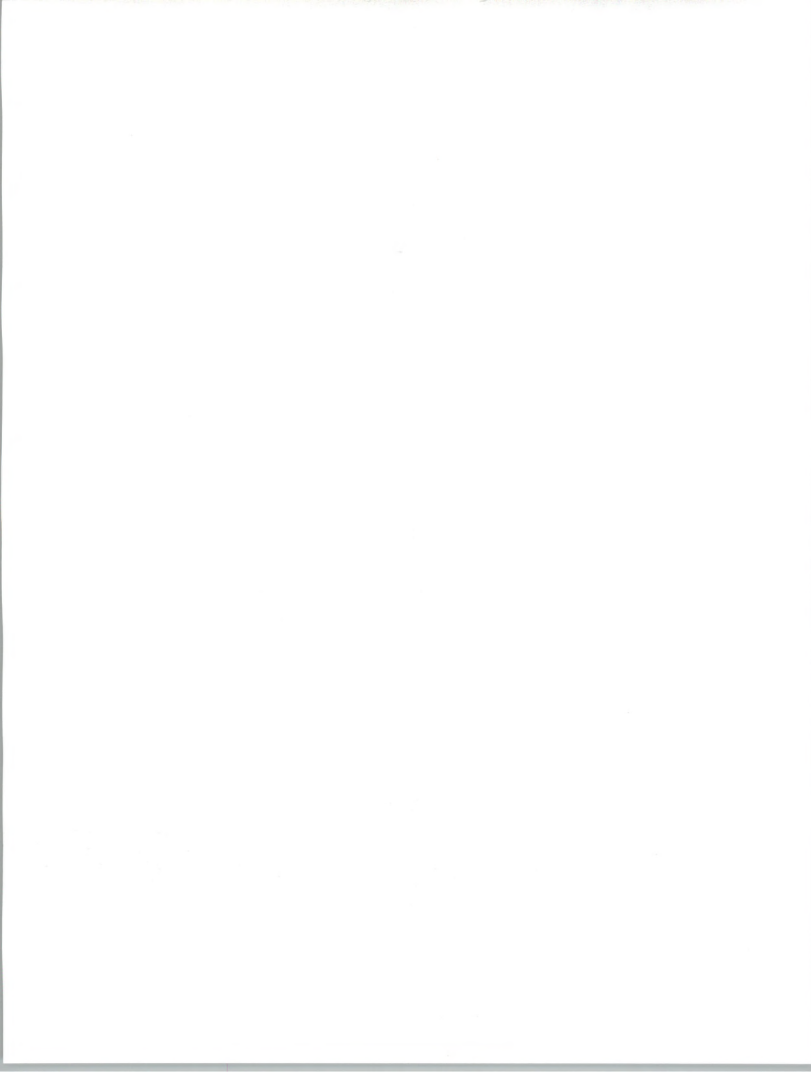

J**Transportation**

The freight transportation industry is divided into motor, rail, air, and ocean carriers; courier services; and transport services, namely freight forwarders and customs brokers. For EDI analysis purposes, also included in the transportation trading community are port authorities and U.S. Customs.

The travel industry, including passenger airline services, hotel and lodging establishments, and car rental services, is classified as services, travel. Pipeline services, sometimes classified under transport, are for this study's purposes classified under the petroleum industry.

Exhibit VII-14 lists the different groups that compose the transportation industry.

EXHIBIT VII-14

**Groups within the Transportation
EDI Trading Community**

- Motor carriers
- Rail carriers
- Airlines
- Ocean carriers
- Air carriers/airlines
- Couriers
- Port authorities
- U.S. Customs
- Transport service providers

The transportation sector, like chemicals, is a core industry in the economy and as such provides services to almost all other sectors. Transportation can be viewed as a "hub" industry, with trading partners—and actual and potential EDI ties—with most other industries. Furthermore, business logistics—transportation and warehousing—has been estimated to equal 14% of U.S. GNP. Half of this (7% of GNP) is attributed to transport costs.



In 1988, the U.S. freight transport market was valued at an estimated \$310 billion in terms of receipts and imputed payments, according to the U.S. Department of Commerce.

Although transportation companies are certainly buyers of goods and services, and therefore candidates for and in many cases users of purchasing-oriented EDI services, this section focuses on how carriers use EDI as a customer service. This variety of EDI is called logistics data interchange (LDI).

The transportation industry is information-intensive. A large amount of data is required at virtually every point in the cargo's journey. The carrier of record must generate and process many documents, especially in international transportation. Much of the information in each document duplicates that on other documents pertaining to the same shipment.

A common EDI-like technology that most large carriers and transport service providers have developed is on-line shipment status data bases. Customers can dial in using a computer or, in some cases, using a touch-tone telephone, to inquire about the location of a shipment. Large ocean shipping companies, trucking companies, railroads, and freight forwarders/customs brokers provide this kind of service. These systems are proprietary in nature, although many are based on quasi data format standards put forth in the 1970s by the American Trucking Association and the National Industrial Transportation League. Originally developed to differentiate transport providers, these systems have practically become a mandatory service offering by all leading carriers.

EDI transaction sets for transportation were originally developed and maintained by the Transportation Data Coordinating Committee (TDCC). This committee has turned over the maintenance of the standards to the ANSI ASC X12 organization. The number scheme of the transaction sets has been preserved. Now they are considered X12 standards.

TDCC is changing its name to the Electronic Data Interchange Association (EDIA) to reflect its new position as a trade industry group serving EDI users in all industries in the U.S.

1. Trucking

Trucking accounts for approximately 77% of all expenditures on transportation services in the U.S., with the balance spent on air, rail, and ocean transport. In 1988, trucking industry revenues approximated \$240 billion.



There are approximately 30,000 trucking companies in the U.S., according to the American Trucking Association. Less than 3,000 have annual sales in excess of \$1 million. These industry leaders are considered class 1 and 2 trucking companies by the Interstate Commerce Commission.

Though these companies do maintain computer systems of some sort, INPUT estimates only 1/3 to 1/6 of them are conducting true EDI (i.e., not counting proprietary shipment status systems).

- Approximately 500 to 1,000 of the trucking industry's largest carriers now perform EDI.
- This number is up substantially from the estimated 70 companies that were EDI-capable in 1988.

The 27,000 class 3 ("mom and pop") trucking companies most likely do not have personal computers, let alone EDI capabilities. However, there are approximately 300 software providers to the trucking industry, so this situation may change.

Truck carriers are further segmented according to the kind of hauling service they provide.

- Less-than-truckload carriers are multipurpose freight haulers that carry more than one customer's freight per truck.
- Truckload carriers service a single customer with a truck.
- Van lines provide hauling for sensitive goods such as household furnishings or electronic/sophisticated equipment. Trucks are equipped with extra smooth suspension systems and trained crews for delicate moving.
- Couriers move freight overnight or other shortened time periods.

a. EDI Applications and Advanced Services

The monthly EDI transaction volume of the EDI-capable carriers ranges from the transmission of a few freight bills with a select few customers to thousands of transactions with hundreds of customers.

- The most dominant transaction set in the industry is the freight bill that the trucking company sends to the customer after the transportation job is completed.
- Following the freight bill in usage is the shipment status report. This is typically sent by the trucking company to the customer at the moments when the truck driver picks up and delivers a freight shipment.

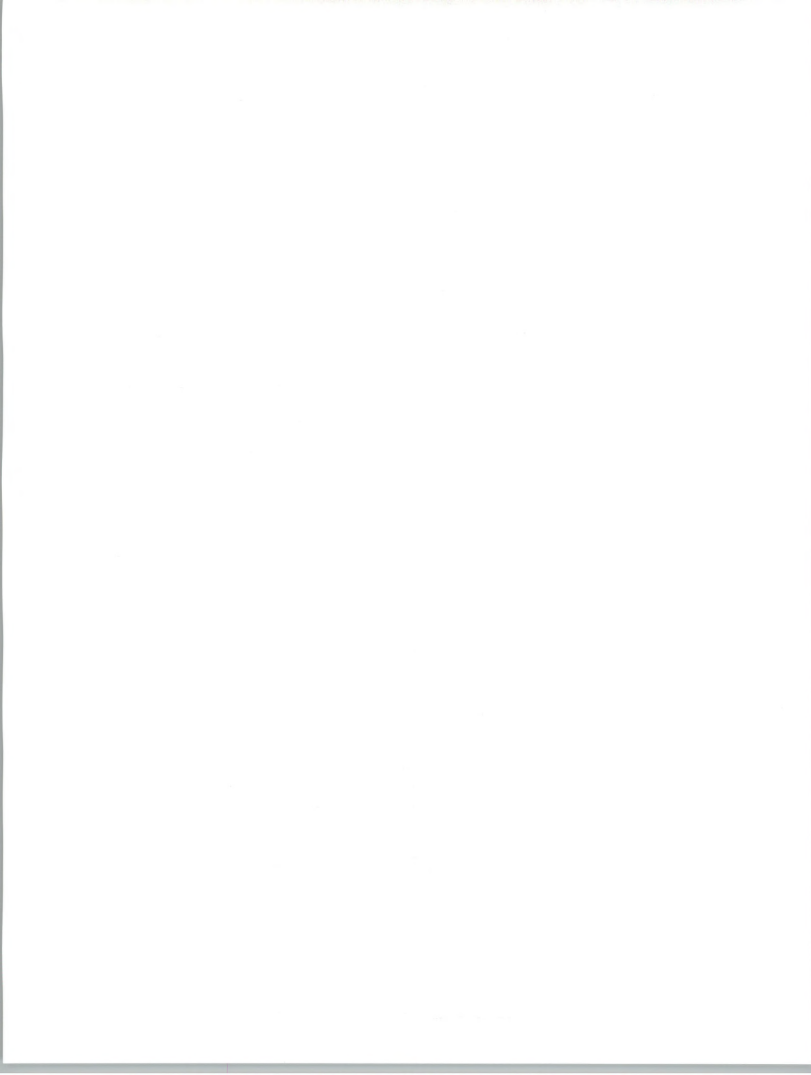

- Next most common is the bill of lading, which the customer sends to the trucker. The bill of lading serves much the same purpose as does a purchase order. Bills of lading are transmitted typically by large Fortune 500 corporations who conduct EDI with many transport carriers and other trading partners in different industries.
- Tariff information (price schedules for hauling) and routing information (lists of geographic points served by the carrier and estimated departure/arrival times) are also in use by major carriers.

The trucking industry is served by approximately 12 rate bureaus whose business is to provide shippers with a comprehensive listing of carriers' shipping rates. Sometimes tariff information is sent by the carrier to one or more of these bureaus.

Trucking companies are beginning to receive payment electronically using the ANSI X12 820 remittance advice/payment instruction transaction set. The U.S. government, particularly the military (which is the trucking industry's largest single customer), is one of the leading payors of trucking companies.

The major trucking companies use and will continue to use a combination of direct and third-party media for the electronic transmission of EDI messages. Often with big customers, trucking companies send X12/TDCC transaction sets in the same direct communication channel used for the on-line shipment inquiry system. No third-party VAN is used. This situation will not change.

In addition to providing direct EDI, on-line data base services, audiotext services, and computer-to-fax services, major trucking companies use more than one value-added network service provider.

Exhibit VII-15 lists the leading EDI users and networks in trucking.

2. Railroads

In 1989, 14 major independent freight railroads or affiliated railroad systems accounted for more than 90% of the carloads handled by the railroad industry. The freight railroad industry also encompasses approximately 500 smaller carriers, including local, regional, and switching and terminal railroads.

After decades of losing traffic to the highways, railroads' share of total freight ton-miles and tonnage shipped in the nation has generally stabilized at just over 35 percent.



EXHIBIT VII-15

EDI Users and Networks in Trucking

- **Leading users:**
 - **Less-than-truckload carriers**
 - Yellow Freight
 - CF
 - Roadway
 - Arkansas Best Freight Systems
 - **Truckload**
 - Snyder National
 - JB Hunt
 - Burlington Motor Carrier
 - **Van lines**
 - North American
 - Mayflower
 - Bekins
 - **Couriers**
 - UPS
 - Roadway Package Systems
- **Leading VANs**
 - Transsettlements, Kleinschmidt, GEIS, IBM IN, and direct connections

The railroads are moving ahead with innovations in equipment, computerized tracking of freight and scheduling of trains, and marketing programs. New types of services, particularly in the area of so-called "piggyback" or intermodal traffic and doublestack container trains are being offered. In spite of steady increases in the volume of intermodal traffic, however, there is still some question in the industry as to how profitable this business is for the carriers.

Since passage of the Staggers Rail Act of 1980, which partially deregulated rail rates and services, railroads have had considerably more flexibility and incentive to improve efficiency, restructure rates and operations, and compete aggressively for traffic.

Railways were one of the first industries to use EDI as a customer service in their marketing strategies, and are now becoming significant users of EDI for purchasing.

Exhibit VII-16 lists the EDI applications related to the railroad industry.

EXHIBIT VII-16

EDI Applications in the Railroad Industry	
Transaction	Trading Partners
Waybills	Among railroad companies
Advance consists	Among railroad companies
Car location messages	Among railroad companies and between RRs and customers
Bills of lading	From shippers to RRs
POs and invoices	Between RRs and suppliers

Approximately 100 railroads conduct EDI in the U.S. Much of this EDI is among railroad companies. Freight hauls involving railroads typically require a single rail car to be passed among multiple railroad companies. These pass-offs are accompanied by paperwork itemizing the contents of the cargo and where it is destined. These are called "waybills."

"Advance consists" are another inter-railroad document that is exchanged via EDI. Consists are the lists that identify a railcar's location in a train, its destination, and its ownership and note if it is carrying hazardous materials.

New regulations in 1990 require railroads to exchange waybills and advance consists via EDI.

The rail industry also conducts EDI with its shipper customers. INPUT estimates that approximately 300 shipper companies conduct EDI directly with railroads. These companies are Fortune 500 industrial/manufacturing firms.

These applications include bills of lading (which the shipper sends to the railroad, functioning as a purchase order) and car location updates (which the railroad sends to the shipper).

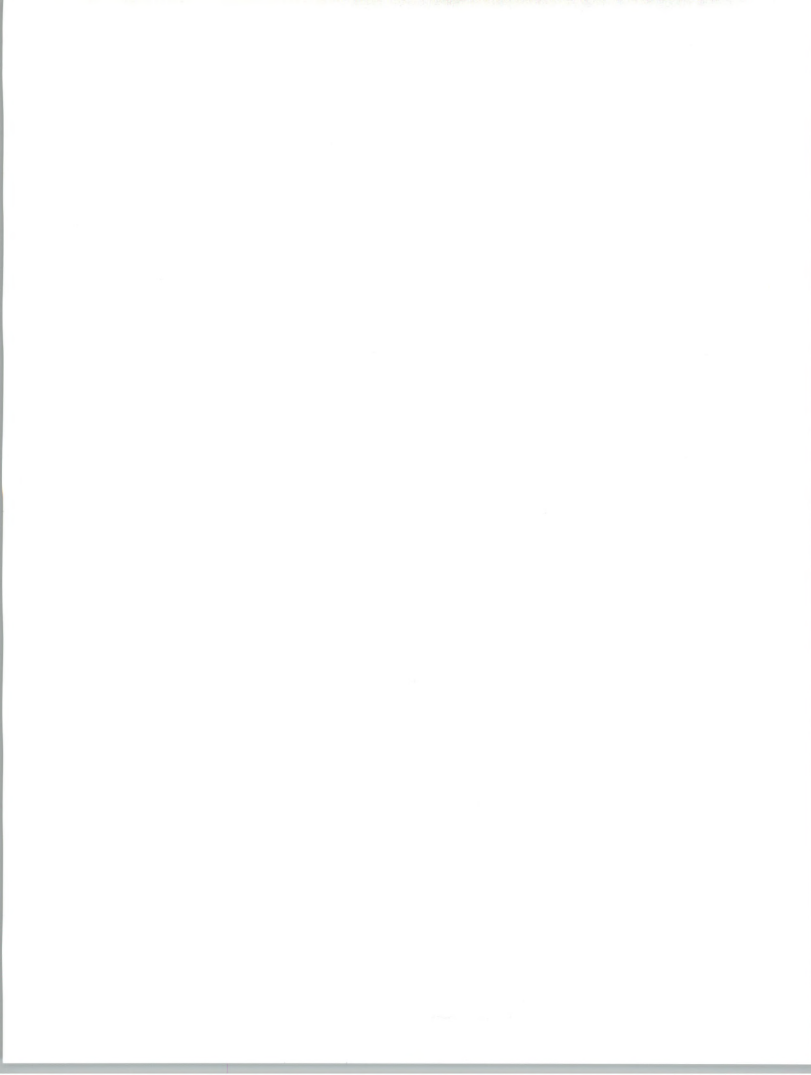

Car location messages were one of the first EDI applications within the rail industry. Since trains exchange railcars as a regular business practice, the owners of the cars (often investors distinct from the railroads themselves) wanted a way to keep track of the location of a given rail car.

Railcars are equipped with automatic identification devices (bar codes originally, and now, more often, passive transponders). Alongside rail tracks are identification scanners. Scanned data is relayed back to a central data base maintained by Railinc, a nonprofit subsidiary of the American Association of Railroads. Car location messages are picked up by railroad companies and relayed to customers as they are requested.

Railroads are also using EDI for their own procurement needs with suppliers of rail steel, ties, electronic equipment, electric power and office supplies.

An early railroad customer service EDI strategy was to offer customers free EDI software that worked only with that railroad's computers. This strategy is giving way to standardized software as more and more rail customers desire to conduct EDI with other industry groups from a single EDI server platform.

Exhibit VII-17 quantifies EDI usage among railroads and their trading partners.

EXHIBIT VII-17

EDI Use by Railroads

Total No. of Users	600
Railroad	100
Shippers	400
Suppliers to RRs	100
Leading Users	CSX Burlington Northern Union Pacific Southern Pacific
Leading VANs	Railinc (350-400) Kleinschmidt (550) BT Tymnet (1,250)

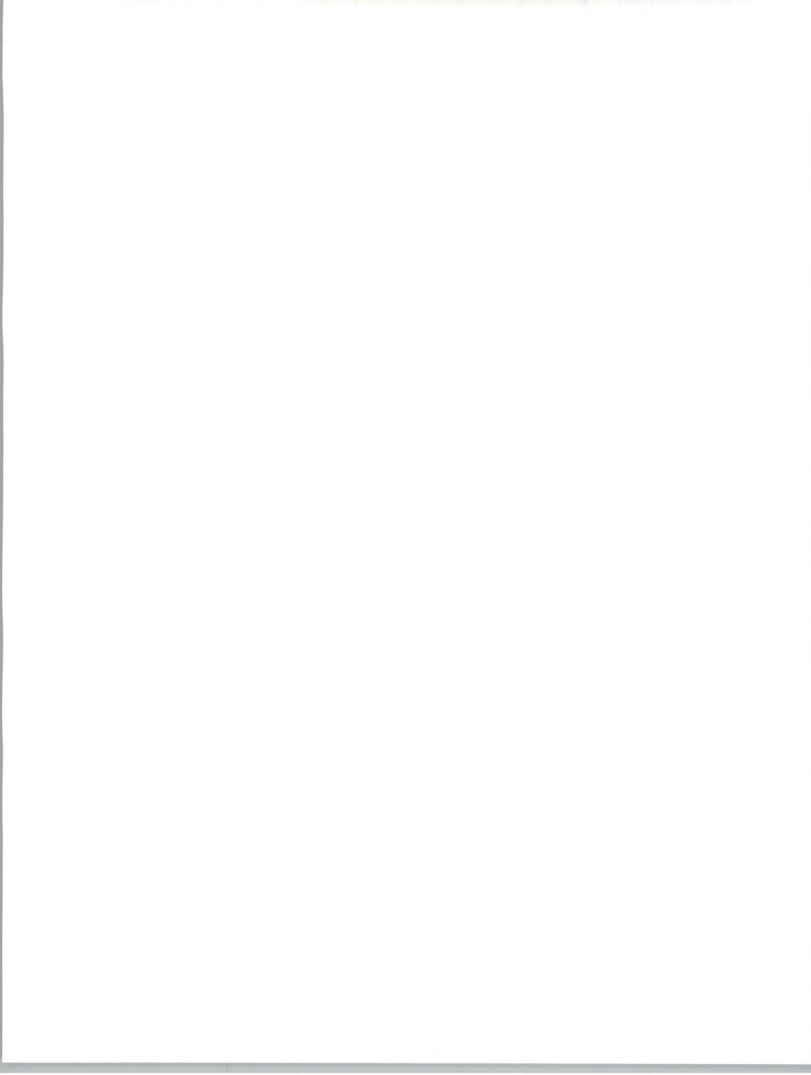

3. Airlines

Passenger airline carriers are using EDI to purchase fuels and airplane spare parts from manufacturers. The EDI capability and network is called Specification 2000 (or "Spec" 2000) and is managed by the Air Transport Association (Washington, D.C.) which is the U.S. domestic body of the International Air Transport Association. EDI is also used by air couriers to interact with shippers and customs authorities (see Air Cargo and Couriers, below). Recently, airlines have begun an effort to use EDI in conjunction with computer reservation systems and related passenger service functions (see Travel and Tourism below, under Service Industries).

Specification 2000 is one of the oldest EDI systems in the world (it began in the late 1950s). Today, approximately 60 airline companies (from the seven continents) and 75 to 80 major parts manufacturers conduct business over it. Though there are approximately 6,000 suppliers to the aircraft industry, and Spec 2000 only has about 2%, the system still captures roughly 70% of the expenditures airlines make for replacement parts and supplies.

In 1989, Specification 2000 launched a product catalog service that allows the manufacturers to place their catalogs on-line for airlines to inspect. Also, in 1989, Spec 2000 launched its AVNET system, a fuel purchasing system. AVNET is the only Spec 2000 service that uses ANSI X12 formats. All else is proprietary. Although some of the member airline companies want to convert all Spec 2000 to a combination of X12 and EDIFACT messages, others are resisting it due to the high software conversion costs. All airline software that interfaces with the Spec 2000 network is developed in-house.

4. International Trade Transportation

By some estimates, eight percent of the value of international shipments are associated with the cost of processing paper.

The movement of freight from one country to another involves freight forwarders, banks, shipping lines, customs authorities, port service operators (such as stevedores and warehousing companies), customs brokers, port authorities, and local transportation vendors (truckers and railroads), as well as the importers and exporters who initiated the freight movement in the first place. Documentation is passed from one to the other along with the freight.

The U.S. community of international transportation vendors (part of the larger global community) is proactively adopting EDI, yet doing so in a haphazard fashion.

Exhibit VII-18 shows the many interfaces among international trade players.



Interfaces in International Trade—Partial List

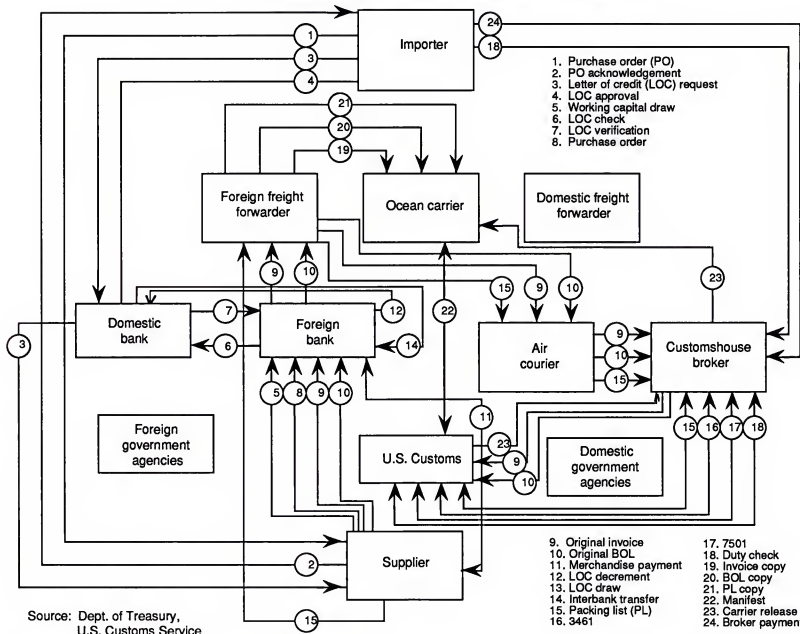



First, a variety of electronic data formats exist. The U.S. Customs agency operates the Automated Commercial System, which accepts EDIFACT formats as well as its proprietary format. Many importers and exporters use ANSI X12 or proprietary formats to initiate/complete commercial transactions. Trucking and railroad vendors interact with intermodal agents using X12 (formerly TDCC formats). Many shipping lines, trucking companies, customs brokers, and freight forwarders offer their own proprietary on-line cargo tracking systems as a customer service.

Second, an increasingly heterogeneous patch-quilt of communication networks are growing and interweaving to serve this community. Port authorities maintain EDI-based networks to support cargo tracking within the port. Shipping lines, trucking companies, freight forwarders and customs brokers offer direct connections to customers for cargo tracking. Customs' ACS is sometimes reachable via a port system, other times it must be dialed directly. Various freight forwarders and customs brokers have formed a consortium and have built a data network that offers tracking services.

GE Information Services has linked its value-added network with the U.S. Customs Service. Shippers, forwarders and transportation companies (especially those outside the U.S.) can automate their ties with the government agency.

The National Customs Brokers and Forwarders Association of America (NCBFAA) is considering establishing a nationwide electronic network to allow importers, exporters, forwarders, brokers, and U.S. Customs to exchange documentation in EDI formats. For more details, see the Transport Services section below.

GE Information Services (GEIS) is positioning itself to be the dominant provider of networking and information services for the worldwide transportation and trade industries.

It has launched Cargo*Link, an international network service that allows data to be exchanged directly from the computers of different companies on the transport chain and provide electronic data interchange services, container tracking and management, satellite communications, and bar code integration for shippers and carriers.

GEIS has divided the global logistics market into three spheres: Asia, Europe, and North America.

With 1992 unification, a GEIS study shows that European transport companies expect a 10% drop in tariff rates (in the U.S., tariff rates fell 30-40% after deregulation). With profit margins already in the one to two percent range, companies will need more efficient information systems.



GEIS is attempting to build a worldwide air cargo communications system that would link local systems in New York, Miami, Frankfurt and elsewhere. Built as a cooperative venture with Philips Electronics and the Dutch software house BCT, the system will provide forwarders, shippers, and carriers with direct, on-line EDI communications to any host computer with one interface. Some large carriers, however, are resisting joining the system. Lufthansa, which has its own EDI network, MOSAIC, that connects brokers, forwarders and customs offices, is not participating in GEIS' network.

How the trade and transportation vendor community, domestically and worldwide, builds an electronic infrastructure is still uncertain. Transport is a niche-driven industry and is highly fragmented. A single, unified information system may not be economical.

a. Deep Sea Shipping

The U.S.-flag deep sea foreign trade shipping industry carries merchandise between U.S. and foreign ports in direct competition with the ships of the world fleet. The industry is small (only 107 vessels, receiving \$5 billion in gross receipts in 1988) and has been in intense international competition for some years.

The leading U.S. companies in shipping are American President Corporation (APC) and Sea-Land. Both are aggressive users of both proprietary and standardized EDI systems. Other non-U.S. shipping lines that service the U.S. include Moller-Maersk Line, Nippon Yusen Kaisha (NYK), Evergreen, Kawasaki Kaisen Kaisha, Mitsui OSK Lines, and Yang Ming Line.

Both APC and Sea-Land maintain extensive networks and real-time systems for customer service operations (especially cargo tracking). They transmit ship manifests to U.S. Customs using Customs' Automated Commercial System. They use standard (TDCC/ANSI X12) EDI formats for communication with customers and other intermodal transport vendors.

Some advanced electronic services that the shipping industry is pursuing are:

- **Tariff Automation.** According to the regulation set forth by the Federal Maritime Commission, shipping companies must file tariffs (transport rates and conditions) electronically to a central data base. The lines to do this in the U.S. are through the commercial information vendor, Transax/RATES (a subsidiary of Knight-Ridder). The Federal Maritime Commission will launch its own data base in 1991, called the Automated Tariff Filing Information system (ATFI).

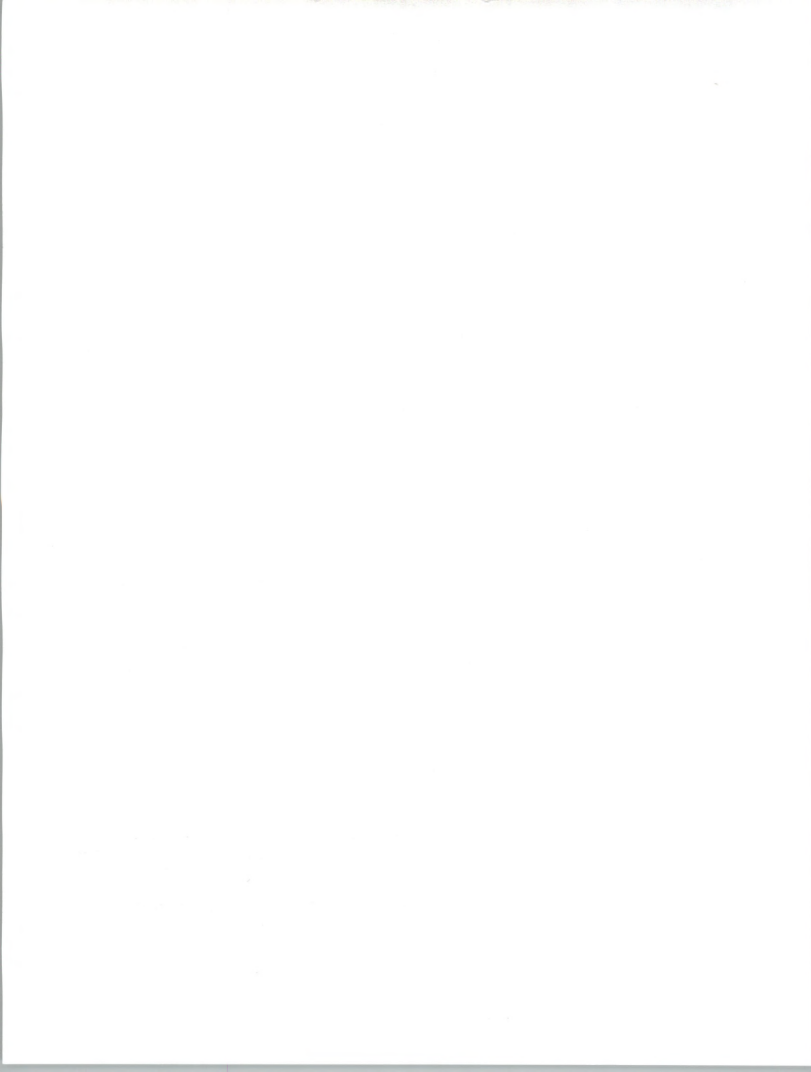

- **Container Tagging.** To track the location of containers as they are passed along among transport vendors, international ship liners are promoting the use of standardized container bar codes/transponders. Already, APC and Sea-Land are tagging containers for better tracking, both as a customer service and for internal control and operational efficiency.

b. Air Cargo and Couriers

The airline industry was one of the original developers of the EDI concept with the launch of the Spec 200 network in the late 1950s. The network, now called Spec 2000 and administered by the Air Transport Association of America (Washington, D.C.), is used for maintenance and fueling of aircraft. It provides a parts ordering system and a jet fuel procurement and settlements system. The fuel procurement system, still being tested, uses ANSI X12 and EDIFACT formats. It links oil companies to airlines, and is known separately as AVNET.

Air cargo carriers, however, have been slow to adopt EDI for the transmission of transport documentation. Proprietary systems between carriers and their customers have existed since the mid-1980s. Only now are standardized interfaces being set up using the TDCC (now ANSI X12) and EDIFACT air freight series of EDI message sets.

The message sets being implemented are primarily:

- The Cargo-Imp message (developed by the International Air Transport Association) for the transmission of freight manifests into customs authorities. Cargo-Imp messages can be translated into EDIFACT formats using IATA's Cargo-Star global network.
- The use of TDCC air bills of lading and freight invoices for electronic communications between shippers and carriers. These are just now being implemented by large air freight shippers or shippers' agents.

Leading couriers involved in EDI are Airborne Express (Seattle, WA), Emery Worldwide, United Parcel Service and Federal Express Corp. (Memphis, TN). Airborne has developed a proprietary system called Linkage, whereby Airborne customers can automate virtually all dealings with Airborne.

- Emery Worldwide uses TDCC air standards and proprietary formats and the ACH for freight bill payments. Its EDI family of services is called Value-Plus.
- Both Airborne and Federal Express are moving to adopt TDCC (now ANSI X12) message types to standardize interface with shippers.

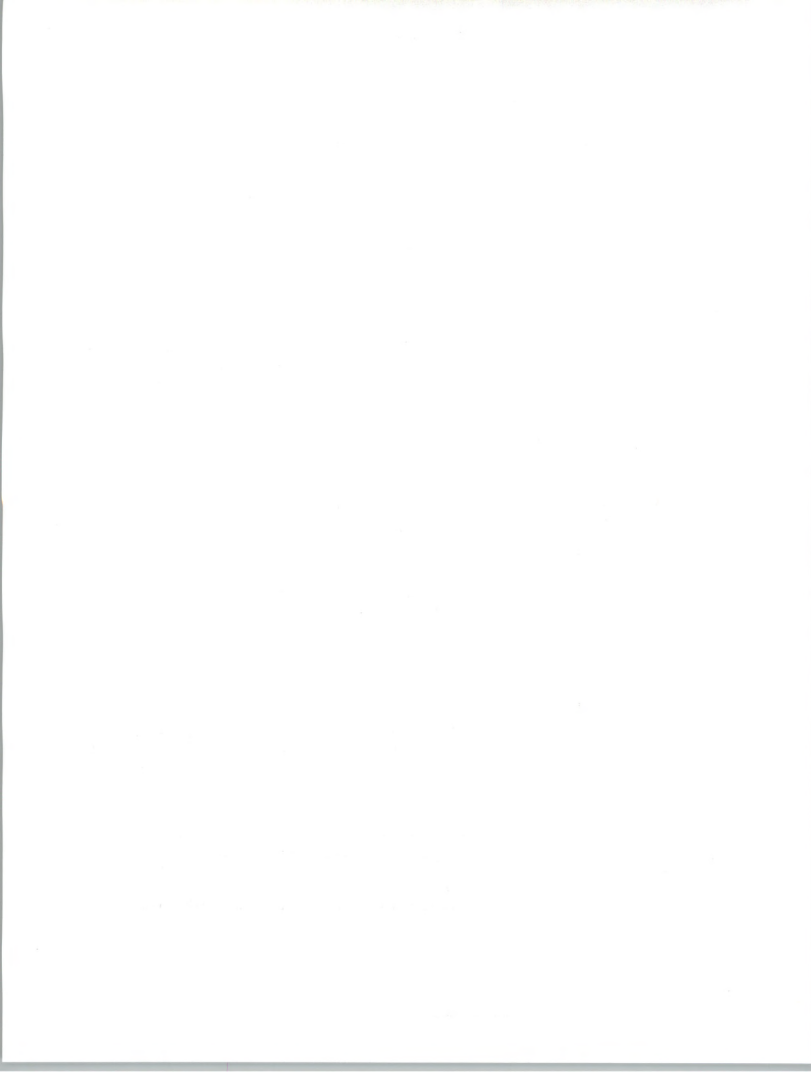

- United Parcel Service (UPS) has implemented EDI connections with CADEX, Canada's Customs Service to speed package delivery between the U.S. and Canada. In February 1990, UPS purchased 1,700 micro-computers from AT&T for \$29 million as part of its ongoing automation effort.

Airline companies (both cargo and passenger services) are, through the Air Transport Association of America and its international cousin the International Air Transport Association, planning to build an OSI-based international messaging network—the Aeronautical Telecommunications Network (ATN). Already, the industry maintains the Society International de Telecommunications Aeronautiques (SITA) network.

The ATN is expected to serve as the infrastructure for global communications among members of the airline industry: the airlines themselves, the FAA and some travel agencies linked to airline reservation systems.

For other airline and passenger air transport EDI, see Airlines above and Services, Travel Industry below.

c. Port Authorities

The typical large international port is a focal point of intense interorganizational communications. Shipping companies, customs houses, warehouse operators, wharf/terminal operators, customs brokers, freight forwarders, truckers, and railroads are handing off the control of cargos whose ownership is that of yet another party. Along with the cargo goes documentation which is updated at each handoff.

To handle this intense interorganizational communication load, ports worldwide are automating. In the U.S., most large port authorities have developed, are developing, or have promised to develop automated EDI-based systems to facilitate intraport communications.

Two general architectures exist for port automation. The older design is the proprietary, port owned and operated system. The port, using its own (typically, mainframe) computer, becomes a mini network provider to all the various parties in the port community. Parties involved with the movement of a given piece of cargo access and update a single data base record for that cargo.

For the second, newer design, the port contracts a third-party network provider to build a "controlled" EDI community for the port. Instead of interacting with a central data base, users send messages to those parties that are relevant to the needs of freight movement. For example, a terminal operator (having just unloaded cargo) sends a message to a

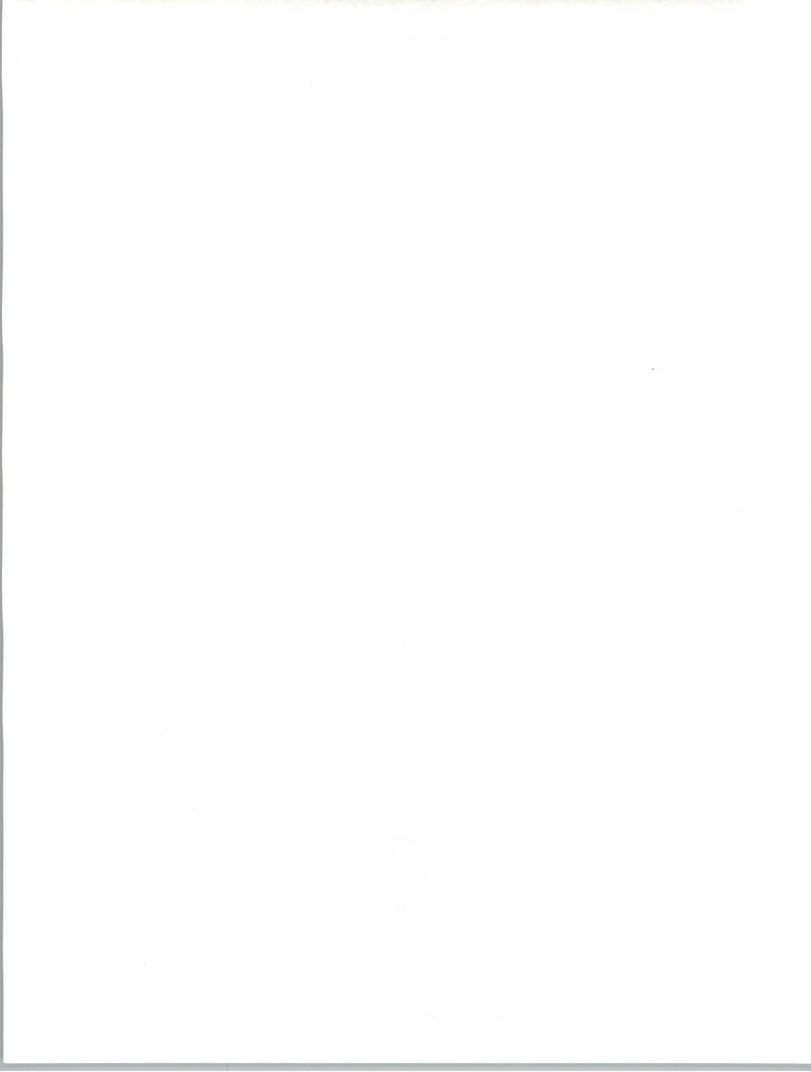

customs broker to pick it up. The customs broker sends a message ("entry") to customs to clear the cargo. Later, the broker sends a message to a trucking company instructing it to pick up the cargo.

The newer architecture is the trend among ports now automating and therefore represents an opportunity for third-party network providers.

- The Port of New Orleans offers a series of computer services called CRESCENT (Computer Reporting and Expediting of Shipments to Control Essential New Orleans Trade). CRESCENT provides interactive manifest preparations, customs forms creation, freight quotes, container tracking, statistics, and a services directory/data base. The system was developed by McDonnell Douglas and is now run by BT Tynnet.
- The Port of Baltimore has implemented the ACROSS service that links to the Customs Automated Manifest System and supports the Automated Broker Interface. Other functions are local cargo tracking, document generation, ship scheduling, statistical reporting, and electronic messaging. It is operated by Network Solutions (Vienna, VA) under subcontract with Arthur Andersen.
- The Automated Cargo Expediting System (ACES) was developed and is operated by GE Information Services for the Port Authority of New York and New Jersey. The Port Authority serves as a coordinating agency for the ocean shipping community.
- The Miami International Cargo System (MICS) is described as the first fully integrated cargo clearance system in the U.S. Similar systems are being implemented in the United Kingdom, France, and Australia by Computer Sciences Corporation and the U.K.-based National Data Processing Service, creating a de facto standardized automated cargo clearance system.
- The Golden Gates Ports Association's (San Francisco, CA) Regional Automated Cargo Expediting and Release System (RACERS) is still under development. It will be operated on a PC and designed around a simple mailbox architecture. Golden Gates Ports include the ports of San Francisco, Richmond, Oakland, Stockton, Redwood City, and Sacramento.
- Port of Philadelphia's TRACS system is still in pilot project stage. The project is expected to become fully operational in the first quarter of 1991.
- The Ports of Seattle and Tacoma (Washington) have awarded Sterling Software/Ordernet the contract to develop the Puget Sound Community Cargo Release System. The system is expected to be fully operational in the second quarter of 1991.

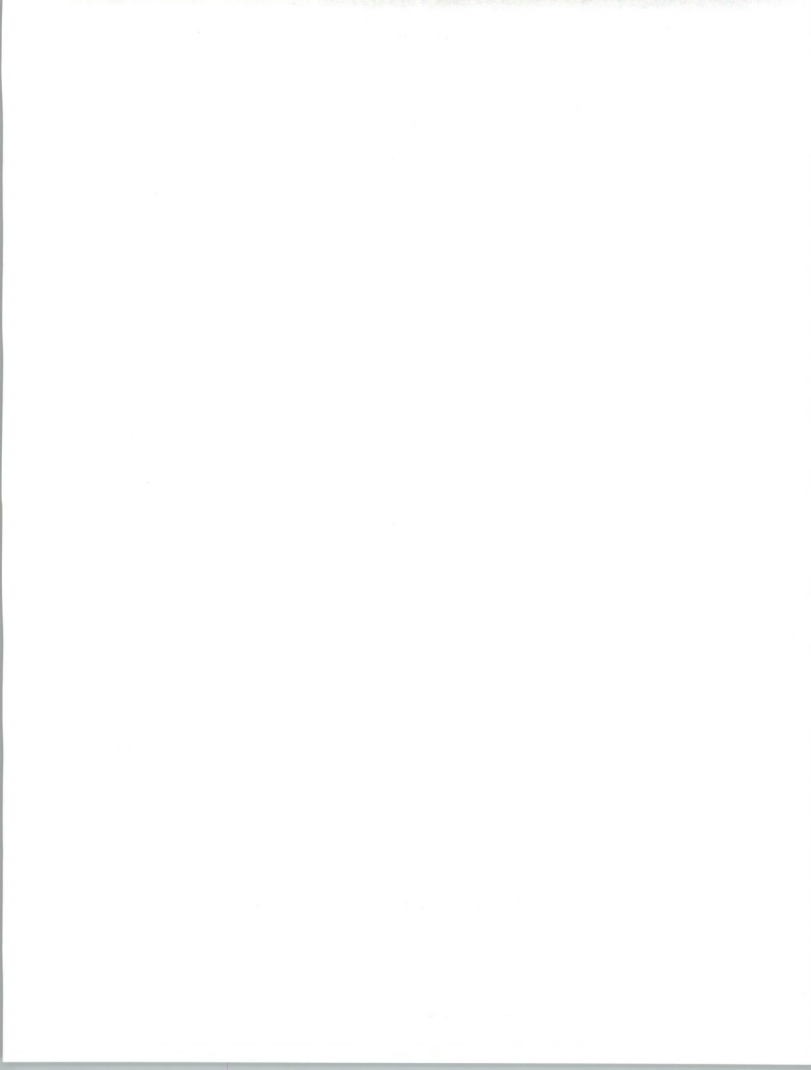

d. U.S. Customs

Amid controversy, U.S. Customs has mandated that documents exchanged from the private sector with Customs be entirely automated. To this end, Customs has implemented the Automated Commercial System (ACS).

The objective of ACS is to speed clearance of routine shipments, often before arrival. There are two ACS modules:

- The Automated Broker Interface (ABI) allows brokers to electronically file necessary documentation. It promotes the key customer benefit of being able to move shipments through customs in hours rather than days.
- The Automated Manifest System (AMS) supports the traditional listing of all cargo transported by a carrier according to destination and other information needed by customs and port officials. The benefits to port authorities will be efficiencies in facility use and the competitive edge of automated ports over those maintaining paper processing.

e. Transport Services—Customs Brokers and Freight Forwarders

A customs broker works on behalf of a shipper to clear imported shipments through U.S. Customs. A freight forwarder works on behalf of a shipper to move freight to a domestic or foreign destination (i.e., exports and/or through many modes of transportation (trucks, railroads, etc.)). Because the two services are allied, many companies provide both services.

The National Customs Brokers and Forwarders Association of America estimates the number of customs brokers in the U.S. to be approximately 1,300 and the number of freight forwarders to be 2,000-4,000 (with companies that provide both services to be counted in the 1,300 number). The NCBFAA has 500 members.

Brokers and forwarders, like other service companies, are moving beyond services and becoming information companies. Many companies provide shipment tracking systems for customers. The systems allow customers to use computers with modems to dial into the broker's or forwarder's computer data base.

Freight forwarder systems typically allow the customer to ascertain when a shipment was picked up, consolidated with other shipments during the course of its delivery, and when the consignee received the shipment. Customs brokers' systems allow the customer to check the progress of shipments through Customs.

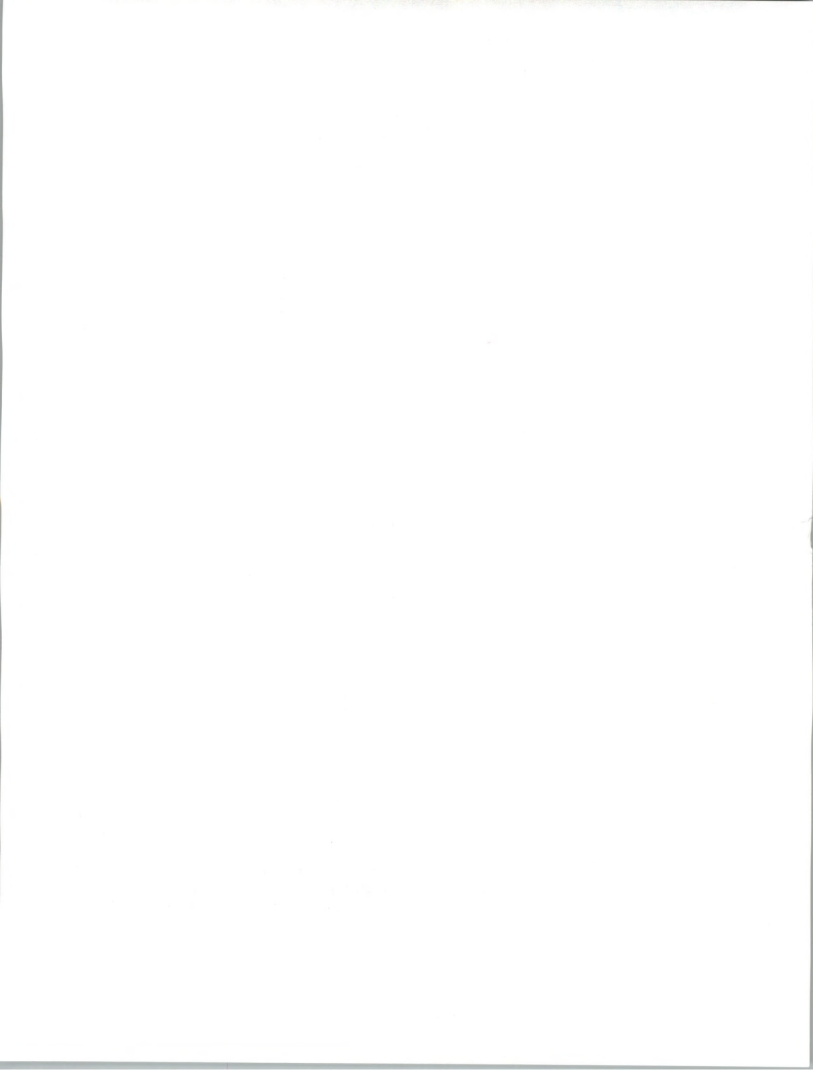

Often, brokers and forwarders provide reporting services for customers, where cost-per-item reports inform the customer of all duties, freight charges, insurance and trucking fees, broker and inspection fees, forwarding charges and other related costs per shipment for a given delivery location. Also, total-elapsed-time-to-deliver information is important to customers.

- Northern Air Freight, a Seattle-based air freight forwarder, provides a cargo tracking system called Pulse. Approximately 100 of Northern's leading customers use it.
- Penson and Co. of New York is an ABI broker. Penson's computer automatically dials Customs' computer every 30 minutes and pulls off status data on its accounts. This data is fed into Penson's customer account files. Leading Penson customers can dial directly into the computer to get this data. Smaller customers interface with a Penson service rep.
- American Distribution Services (Memphis, TN), part of American President Cos., Inc. (Oakland, CA), is an intermodal forwarder with on-line systems for customers.
- World Trade Services Inc. (Beaverton, OR), recently acquired by transportation conglomerate CSX Corp. (Richmond, VA), provides extensive tracking features to customers in addition to a data network service for other customs brokers and forwarders.
- Other broker/forwarder companies with electronic capabilities include: Castellazo and Associates (Los Angeles, CA), Merit Steamship Agency Inc. (Los Angeles, CA), and Ocean Air International Inc. (Pittsburgh, PA).
- The National Customs Brokers and Forwarders Association of America (NCBFAA) is considering establishing a nationwide electronic network to allow importers, exporters, forwarders, brokers, and U.S. Customs to exchange documentation in EDI formats. Such a network would work in conjunction with port-based systems and Customs' Automated Commercial System (ACS).
- Shippers would use the system to determine the status of shipments, send bills of lading to forwarders, initiate brokering/forwarding services, supply further trade-related documentation to Customs, etc.
- Brokers and forwarders would use the system to communicate among themselves, as is often necessary when two brokerage firms, one on each coast, team together to provide service to a single account.

Faint, illegible text, possibly bleed-through from the reverse side of the page.

The NCBFAA's proposal coincides with the launching of a similarly focused network in the U.K., the Freight Forwarder Network of Trade Network International. This network serves freight forwarders, customs brokers and shippers in the U.K. and Europe. Trade Network International is trying to establish a trade community network in the U.S. through its subsidiary, Export Network.

A number of network providers have expressed interest in the NCBFAA proposal. They include: Export Network, GEIS, IBM Information Network, Kleinschmidt Inc., and World Trade Services, Inc. (a subsidiary of CSX Corp.).

K

Utilities

With substantial computing and information technologies at their disposal, power utilities have implemented various EDI-allied systems, such as remote equipment monitoring, since the 1970s. It wasn't until around 1987 that leading utilities began X12 EDI projects, however. Utility companies have a user group that meets under the aegis of the ANSI X12 Accredited Standards Committee. As of mid-1990, approximately 12 utilities in the United States are conducting EDI and 30-35 more are preparing their first EDI pilot projects.

Utilities are using EDI for equipment purchasing from upstream suppliers as well as service billing to downstream customers. Exhibit VII-19 depicts the transaction structure of the power utility industry.

Harbinger has worked with a number of the leading utilities to launch EDI programs (viz. Georgia Power and Southern California Edison), but it is not the mandated service provider of the industry.

The utility industry is marked by two types of providers: the investor-owned company (which is regulated by public utility commissions) and consumer-owned "co-ops," which were founded in the 1930s to supply power in rural areas (and are therefore regulated by the Federal Rural Electric Agency). The investor-owned utilities are conducting EDI.

1. Utility EDI Purchasing

Key suppliers to utilities are electrical equipment manufacturers and distributors. Typically, utility supply purchases adhere to this pattern:

- "Big-ticket" items (such as distribution transformers, which cost \$500-700 each) purchased directly from manufacturers
- Inexpensive commodity parts (nuts and bolts) purchased from distributors

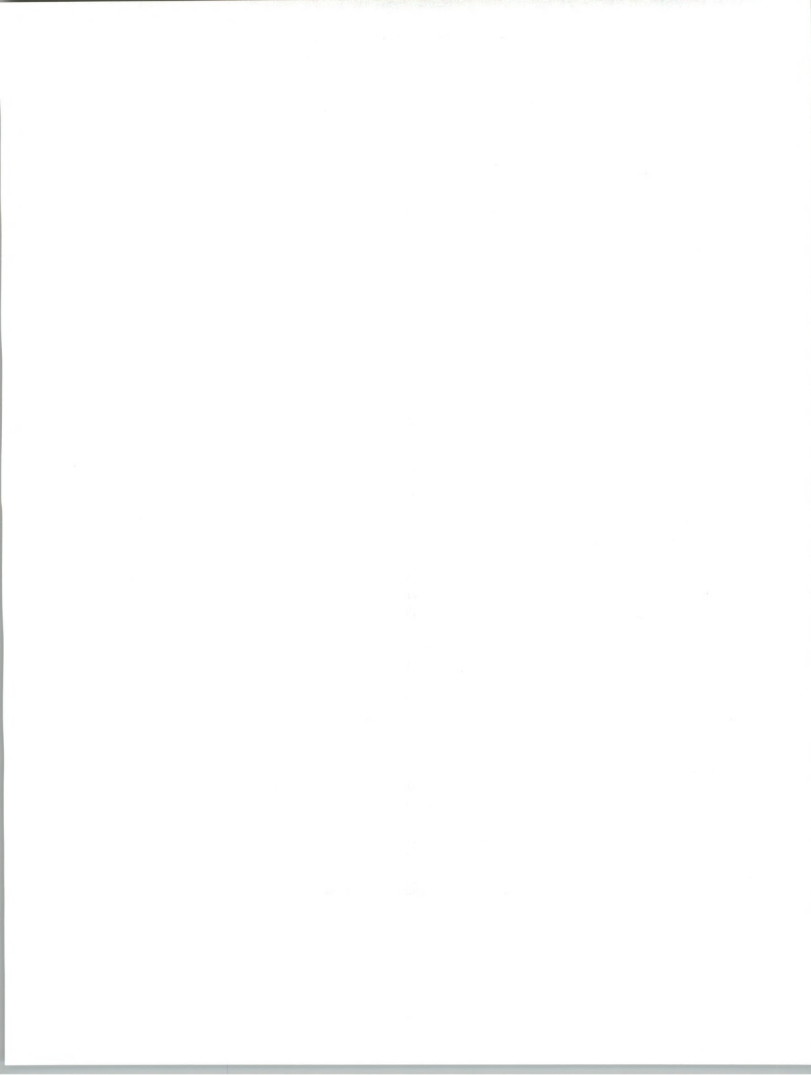
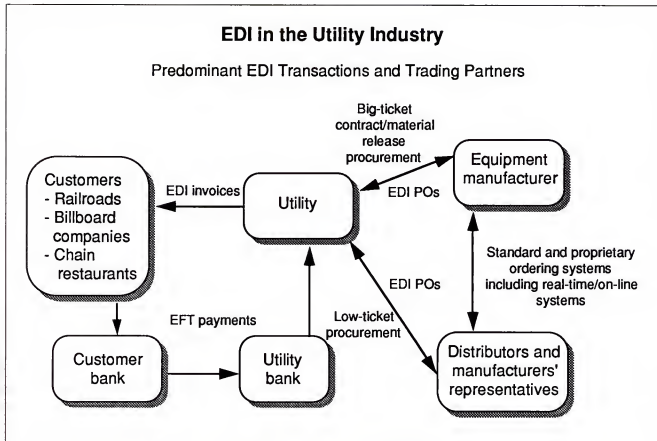

EXHIBIT VII-19



Also characteristic of utility company procurement practices is the use of material releases against blanket purchase orders.

Utilities award annual procurement contracts to vendors, against which material releases are made throughout the year. Utility companies are using EDI to send these material releases.

2. Utility EDI Billing

Power customers that maintain hundreds of properties, each with their own power meter, are asking utilities for consolidated billing. Such companies include railroads (each railroad crossing has a power meter), fast food restaurant chains, and billboard companies (each lighted billboard has a meter).

Led by Consumers Power (Jackson, MI), utility companies are using EDI to consolidate power bills for customers.

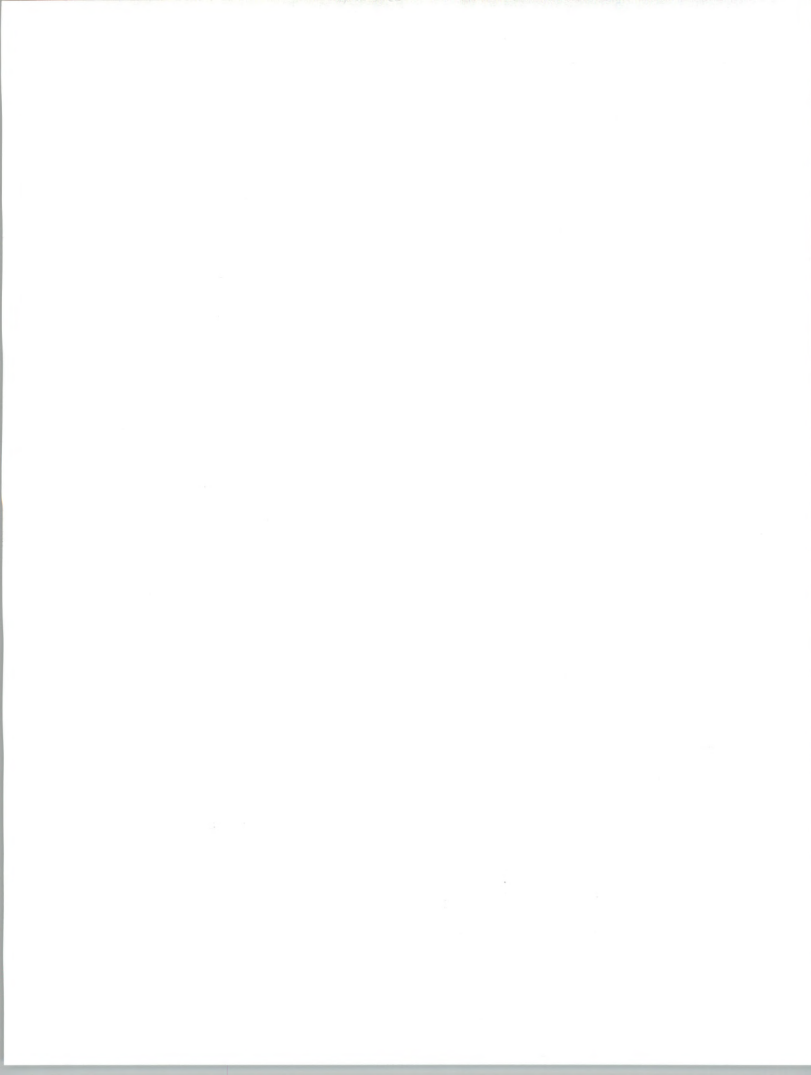

3. Electronic Payments

Utility companies are also making electronic payment for power an option to customers.

Exhibit VII-20 lists statistics on EDI use in the utility industry and related community.

EXHIBIT VII-20

EDI Use in the Utility Industry

Leading users and trading partners:

Customers	Utilities	Suppliers
Railroads	Georgia Power	Westinghouse
Billboard cos.	Consumers Power	General Electric
Fast food cos.	Southern California Edison	Asea Brown Boveri
	Duke Power	

Number of EDI users: 12 active, 30-35 planning

Leading value-added network: Harbinger

Electronic Payments: A few cases with large power customers.

L

Communications Industry

The communications sector consists of a wide variety of business types. Those using EDI are listed in Exhibit VII-21.

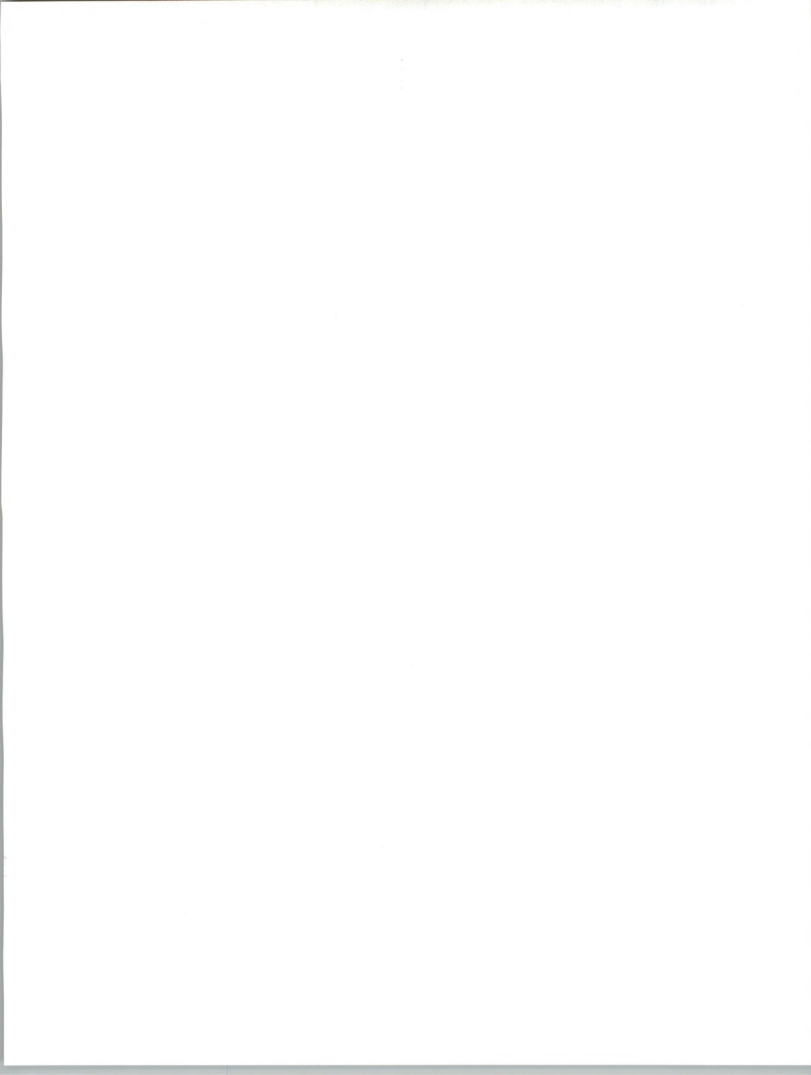

EXHIBIT VII-21

**EDI Use in the Communications Industry
(Selected Applications)**

- Telecommunications
- Film distribution
- Advertising
- Commercial data base vendors

I. Film Distribution

The movie industry has interorganizational data transfer needs and is in the process of adapting X12 formats for these purposes. The Motion Picture Association of America backs the development of EDI standard formats.

A group of seven leading film distributors has targeted 10 document types for conversion to electronic formats. Initially, the group will concentrate on two: the box office statement and the co-op agreement.

Exhibit VII-22 identifies the three documents that film industry companies want to convert to EDI.

EXHIBIT VII-22

Film Industry Transaction Sets

- **Box Office Statement**—Itemizes attendance/ticket sales per movie, per theatre, per week. Sent by movie exhibitors (theatres) to distributors (studios).
- **Co-op Agreement**—Itemizes how the exhibitor and distributor will split advertising costs. Sent by the distributor to the exhibitor.
- **Film Booking Statement**—Lists all theatres nationwide that will run a given movie and the opening dates. Sent by distributor to industry service providers.

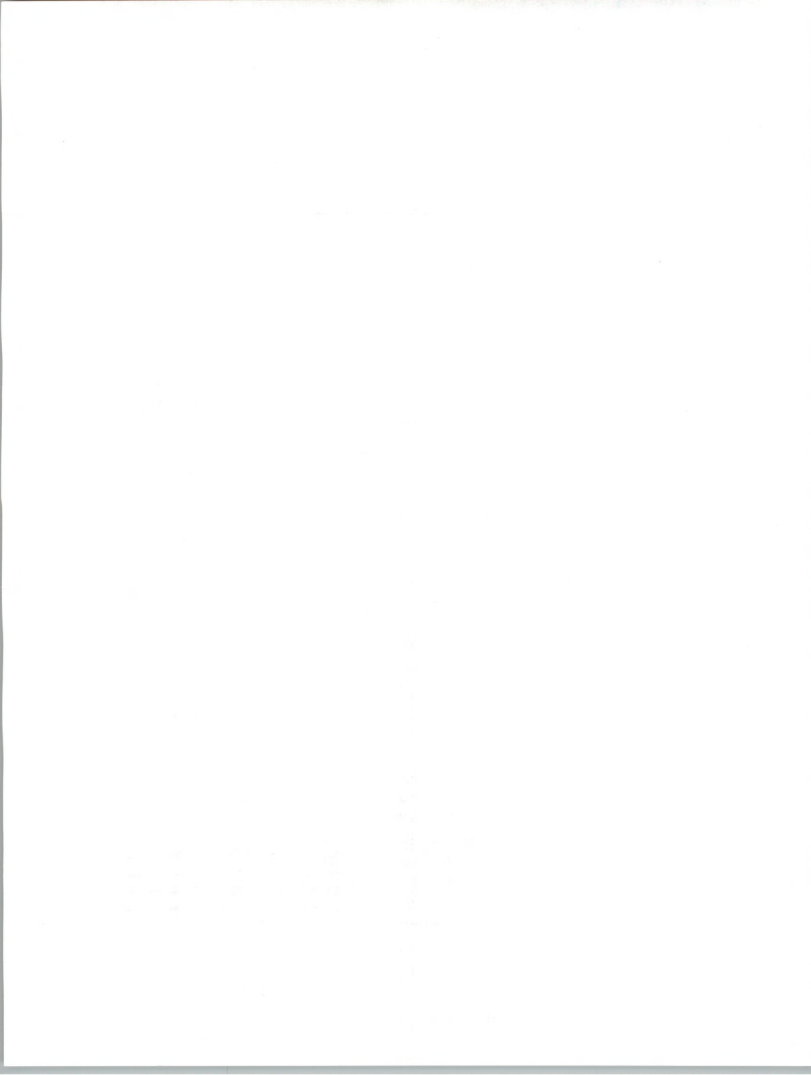

A distributor receives 150,000-350,000 box office statements per year. Currently, the data from these statements are manually keypunched into financial reporting systems by data entry clerks.

There are approximately 23,000 screens in the United States. Box office statements are filed for each screen once a week, for an annual total of about 1.2 million statements.

Invoicing by film distributors to theatres probably will never occur via EDI, according to industry officials. The amount a theatre owes a distributor depends on how well the movie does at the box office. Agreements are often settled by phone.

The box office statement shouldn't be confused with the reports of the first weekend of a newly released film. Box office sales for these films are collected over the phone. Entertainment Data, Inc. (Beverly Hills, CA) calls movie theatre managers across the country and asks gross sales figures. The data is entered into a data base. Entertainment Data generates reports and both electronically transmits them directly to distributor computers and sends hardcopy printouts by courier to studio executives. Entertainment Data also electronically sends the raw data that was collected by direct transmission. The reports and data are sent daily.

The flash gross reports help studio executives determine advertising strategies for the following week and project receivables, among other business actions. The reports, often statistically derived from representative samples, serve a different purpose than the empirically exact box office statements (which form the basis for distributors and exhibitors to share receipts).

Entertainment Data is considering implementing X12 EDI with movie theatres. Entertainment is not concerned about losing its business by automating theatres in this way (the theatres could send the same data to competitors). Very few theatres will ever be capable of EDI, it says. Besides, the company gathers statistics on other theatre activities, such as preview showings.

The movie industry already has implemented a proprietary EDI system for the distribution of films to exhibitors. National Film Service (New York City) serves the industry by physically distributing prints of films to exhibitors nationwide. The company maintains a network of depots across the country. Film distributors ship movie prints to the depots. When the distributor decides to release the film, it sends a "shipping sheet" to the depot. NFS and film distributors are converting the shipping sheet to an EDI system. So far, NFS has two film distributors on the system. According to industry officials, the shipping sheet will not be put into X12 formats.



Another transaction set the film industry is considering making into a standard is the "film booking statement." This tells in which theatres and at what dates a certain movie will be shown. Movie distributors would send the film booking statement to companies such as Entertainment Data (so that Entertainment Data would know which theatres to survey) and National Film Service (so that National would know where to send prints).

Exhibit VII-23 illustrates EDI linkages in the film industry.

Companies in the Motion Picture EDI Committee are Columbia, Warner Brothers, Twentieth-Century Fox, Orion, Disney/Touchstone, MCA/Universal, and Paramount.

2. Commercial Data Base Vendors

Leaders in the commercial data base market include Dow Jones, Mead Data Central, Maxwell, Knight-Ridder/Dialog, TRW, and Equifax.

The data base field is wide open to EDI opportunities.

As mentioned in more detail in INPUT's *Advanced EDI Services* report, EDI can be a foundation for many types of data base services. Data bases can be created by counting EDI transaction traffic (such as Sterling Software/Ordernet's MarketQuest offering) or they can be created based on individual EDI records—for example, the material safety data sheet data base or Universal Product Code (UPC) data bases.

3. Graphics Data Bases

Continental Graphics (Los Angeles, CA) is the largest printer in Los Angeles. One of its market niches is the printing and maintenance of technical documentation for aerospace manufacturers. Continental stores the graphical data (exploded parts diagrams, etc.) electronically. It has converted some of the accompanying textual specification data of the graphics data base to feed the Specification 2000 data base that airlines use to order replacement parts. Specification 2000 is an EDI-based system. The graphics catalog of Continental shows how graphical information can be moved into an EDI context. Moore Business Forms (also a traditional paper printer) has a similar capacity—the movement of digitally represented graphic documents via EDI.

4. Library of Congress and University Libraries

The classification and cataloguing of books requires preparing a control card for each book published. Rather than have all the libraries of the country prepare these control cards on their own and, thereby, duplicate



EXHIBIT VII-23

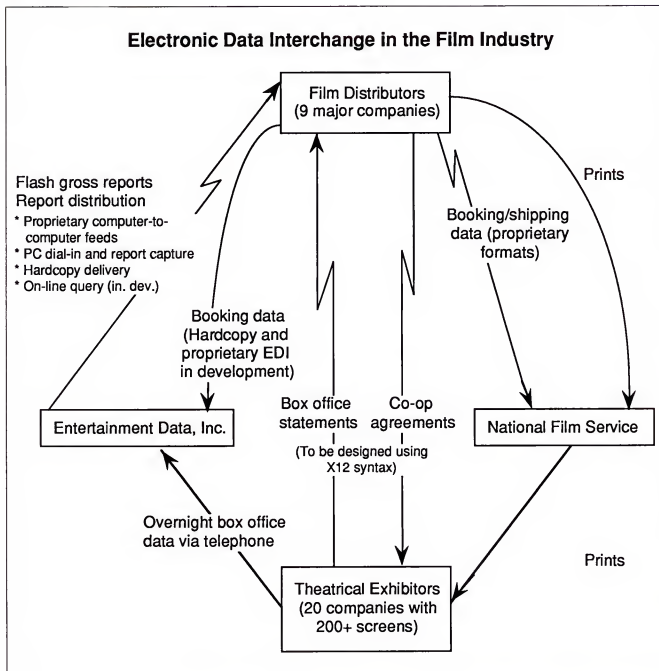

their efforts, the Library of Congress has implemented a program where it prepares control cards and puts them in an electronic data base. Libraries can call up the data base, download the card and use it in their own system. It is similar to the UPC catalog for retailers and apparel manufacturers.



The movement of cataloguing card data has been standardized around the ANSI Z.39 standard. The same standard also specifies a query message. A researcher prepares the query and puts it on a network. The message interrogates all bibliographic data bases that are attached to the network and extracts relevant materials. The idea is to interconnect the on-line card catalogs of libraries within a region or throughout the country. Already, through the Internet, such interconnection of academic libraries and the Library of Congress is taking place.

5. Advertising

Donavan Data Systems (NY, NY) performs billing and payment services for advertising companies. It receives bills for individual spot media placements from television and radio broadcasters. It pays the bills, consolidates them, and passes them on to the advertising agencies. It is examining the use of EDI for various data exchanges between its trading partners.

Decision Point Marketing, Inc. (Winston-Salem, NC) provides various Reynolds subsidiaries (Tobacco, Planter's Peanuts) with store displays and three-dimensional advertising materials. The company receives EDI purchase orders and sends invoices. Decision Point and Reynolds work out the ad paraphernalia in conventional client-service firm meetings. Once the material is finalized, Reynolds and Decision Point coordinate the dissemination of the material using EDI.

M

Finance

A more detailed analysis of EDI in finance is found in INPUT's report, *EDI and Financial Services*.

1. Banking

Banks are both users of EDI—to purchase office supplies, equipment, etc.—and service providers to other EDI users (corporate clients), to enable buying corporations to electronically pay selling corporations.

Bank usage of EDI for procurement is not large because banks, as service providers, have no physical inventory to carry and therefore have relatively little need for material procurement.

Ironically, the supplier type most frequently mentioned by banks who are connected via EDI are business forms vendors (ironic because EDI is designed to eliminate paper forms). Consequently, even some of the leading bank providers of EDI/EFT services conduct EDI with only 5-15 suppliers.

This section will concentrate on banks as service providers.



a. Banks as Service Providers

Banks provide corporate customers with various electronic funds transfer services including lockbox, direct deposit of payroll, government payments, preauthorized debits, cash concentration, wire transfers, various cash management services, etc. Banks also use EFT for their own purposes to settle commercial obligations with other banks.

It is useful to distinguish EFT used in conjunction with EDI from other kinds of EFT. Financial EDI pertains to EDI transactions that involve finance-related information—namely invoice, payment, and payment advice.

Exhibit VII-24 shows the relationship between EDI, EFT and financial EDI.

EXHIBIT VII-24

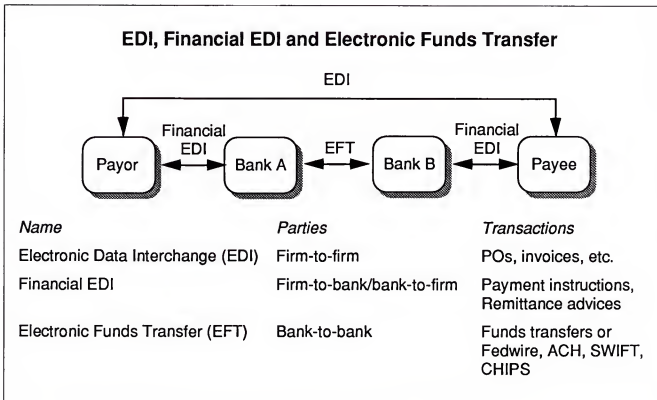

b. Financial EDI Market Size

Corporate-to-corporate electronic payments (financial EDI) are just one type of electronic funds transfer service that banks offer their corporate customers. Of all the EFT practiced today in the U.S. (e.g., lockbox, ATM transfers, interbank transfers, etc.), financial EDI is still less than one percent of the whole.

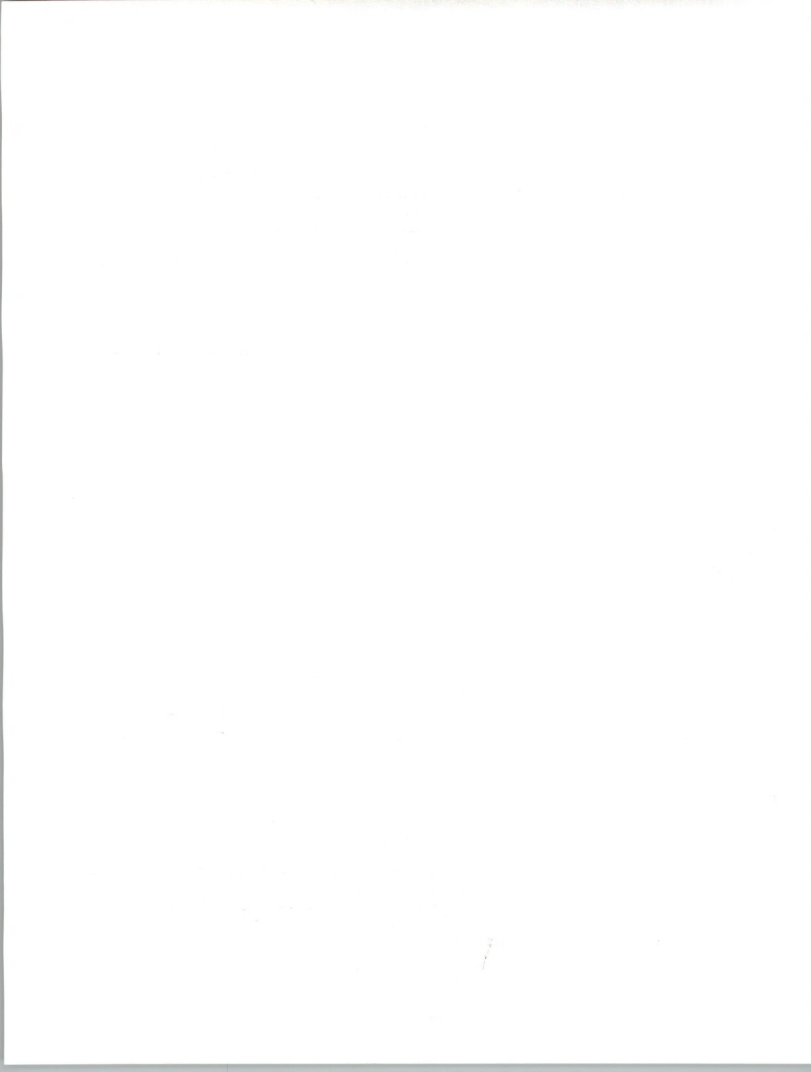

In 1989, approximately 10 billion corporate-to-corporate payments were made. Only 1.3% of these payments were made electronically.

Banks have four main mechanisms to move funds electronically between different banks: FedWire, The Automated Clearinghouse (ACH), the Clearing House for Interbank Payment Systems (CHIPS), and the Society for Worldwide Interbank Financial Telecommunications (SWIFT).

The ACH is the electronic payment mechanism that has been explicitly designed to displace checks. Electronic intercorporate payments take place on the ACH.

According to the National Automated Clearing House Association (NACHA), the secretariat of the ACH, in 1989 \$5.1 trillion worth of funds transfers were enacted on the ACH for a total of 1.3 billion discrete electronic transactions on the network.

Roughly two-thirds of these transactions were commercial sector funds transfers and one-third were governmental.

Exhibit VII-25 shows the volumes of electronic funds transfers on the ACH in the private and public sectors for selected years.

INPUT estimates that approximately 39 million to 130 million electronic corporate-to-corporate EFT payments were made in 1989 and will rise 23% to 48 million to 160 million payments in 1990.

This estimate assumes that the proportion of corporate payment activity to overall ACH activity for a regional ACH processor (Cal Western ACH Association) is representative of NACHA's overall national volume. (NACHA does not provide disaggregated data).

Note:

- Total ACH activity includes transactions for point-of-sale, PPDs (including preauthorized debits and direct deposit of payroll), CCD, CCD+, CTP, and CTX formats.
- Corporate payment activity consists of the debit and credit transactions of the CCD, CCD+, CTP, and CTX formats only.
- INPUT makes a high and low estimate of corporate payment activity. The high estimate includes the CCD and CCD+ debit transactions but the low estimate does not count these. CCD/CCD+ debits are often intracompany transfers where a single company is simply concentrating its funds into a single bank. However, a certain unknown percentage of these transactions are used for corporate-to-corporate payments.

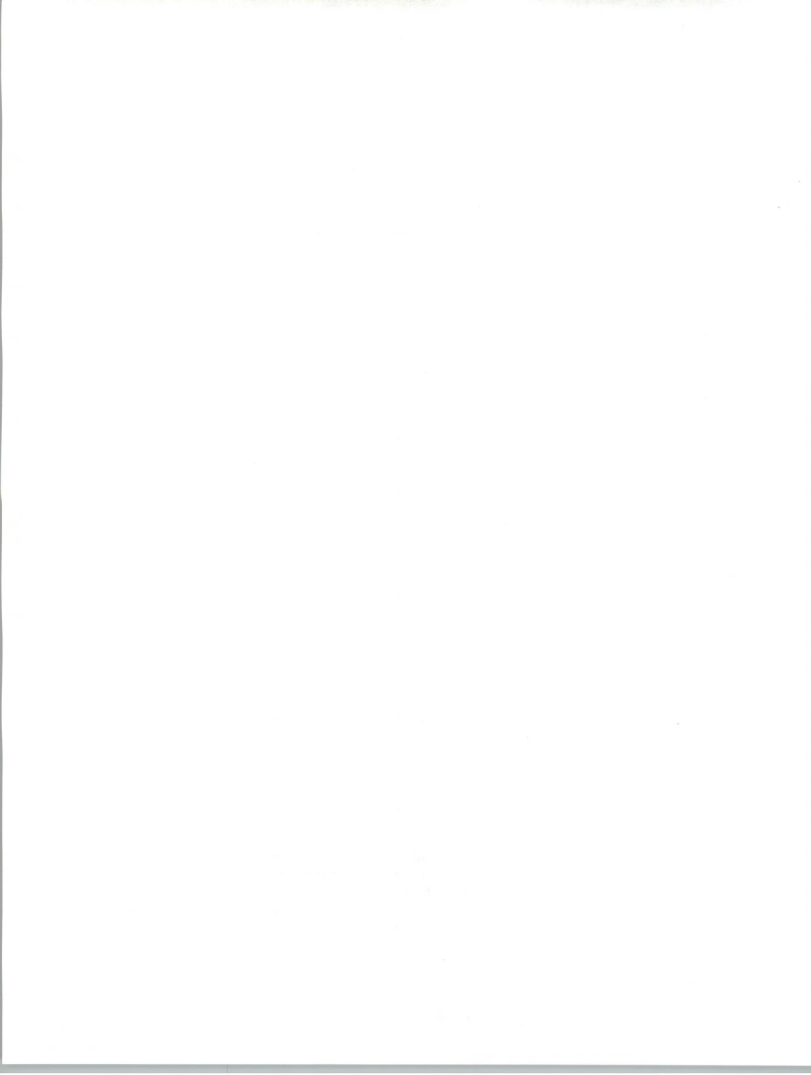

U.S. Electronic Trade Payment Transactions Selected Data

Year	ACH				E	F	G	H
	A	B	C	D		ACH		
	Total Transactions (Billions)	Value (\$ Trillions)	Total Commercial Transactions (Millions)	Corporate Payment Transactions Only* (Millions)	Total Corporate Payments (paper, elect.)	Total Government Transactions (Millions)	Vendor Express Only (Millions)	Total Government Payments (paper, elect.)
1990 est.	1.6			160			3 est.	
1989	1.3	5.1	844	130	10	487	1.8	77 million
1988	1.1	4.2	671	110		442		
1987	.935		528			407		
1986	.750		398			352		
1985								
1984	.535							

Includes transactions for:
 POS
 PPD
 CCD
 CCD+
 CTP
 CTX

Includes transactions for:
 CCD
 CCD+
 CTP
 CTX (debits and credits)

*INPUT estimate

the 1990s, the number of people aged 65 and over in the United States is projected to increase from 20 million to 35 million.

As the number of people aged 65 and over increases, the number of people aged 75 and over is also projected to increase. In 1990, there were 10 million people aged 75 and over in the United States. By 2010, this number is projected to increase to 15 million.

The increase in the number of people aged 75 and over is projected to be even greater for people aged 85 and over. In 1990, there were 2 million people aged 85 and over in the United States. By 2010, this number is projected to increase to 4 million.

The increase in the number of people aged 85 and over is projected to be even greater for people aged 95 and over. In 1990, there were 0.5 million people aged 95 and over in the United States. By 2010, this number is projected to increase to 1 million.

The increase in the number of people aged 95 and over is projected to be even greater for people aged 100 and over. In 1990, there were 0.1 million people aged 100 and over in the United States. By 2010, this number is projected to increase to 0.2 million.

The increase in the number of people aged 100 and over is projected to be even greater for people aged 105 and over. In 1990, there were 0.01 million people aged 105 and over in the United States. By 2010, this number is projected to increase to 0.02 million.

The increase in the number of people aged 105 and over is projected to be even greater for people aged 110 and over. In 1990, there were 0.001 million people aged 110 and over in the United States. By 2010, this number is projected to increase to 0.002 million.

The increase in the number of people aged 110 and over is projected to be even greater for people aged 115 and over. In 1990, there were 0.0001 million people aged 115 and over in the United States. By 2010, this number is projected to increase to 0.0002 million.

The increase in the number of people aged 115 and over is projected to be even greater for people aged 120 and over. In 1990, there were 0.00001 million people aged 120 and over in the United States. By 2010, this number is projected to increase to 0.00002 million.

The increase in the number of people aged 120 and over is projected to be even greater for people aged 125 and over. In 1990, there were 0.000001 million people aged 125 and over in the United States. By 2010, this number is projected to increase to 0.000002 million.

The increase in the number of people aged 125 and over is projected to be even greater for people aged 130 and over. In 1990, there were 0.0000001 million people aged 130 and over in the United States. By 2010, this number is projected to increase to 0.0000002 million.

The increase in the number of people aged 130 and over is projected to be even greater for people aged 135 and over. In 1990, there were 0.00000001 million people aged 135 and over in the United States. By 2010, this number is projected to increase to 0.00000002 million.

The increase in the number of people aged 135 and over is projected to be even greater for people aged 140 and over. In 1990, there were 0.000000001 million people aged 140 and over in the United States. By 2010, this number is projected to increase to 0.000000002 million.

The increase in the number of people aged 140 and over is projected to be even greater for people aged 145 and over. In 1990, there were 0.0000000001 million people aged 145 and over in the United States. By 2010, this number is projected to increase to 0.0000000002 million.

The increase in the number of people aged 145 and over is projected to be even greater for people aged 150 and over. In 1990, there were 0.00000000001 million people aged 150 and over in the United States. By 2010, this number is projected to increase to 0.00000000002 million.

The increase in the number of people aged 150 and over is projected to be even greater for people aged 155 and over. In 1990, there were 0.000000000001 million people aged 155 and over in the United States. By 2010, this number is projected to increase to 0.000000000002 million.

The increase in the number of people aged 155 and over is projected to be even greater for people aged 160 and over. In 1990, there were 0.0000000000001 million people aged 160 and over in the United States. By 2010, this number is projected to increase to 0.0000000000002 million.

To use the CCD/CCD+ debits as an intercorporate payment mechanism, the payee must get authorization from the payor to make the electronic debit. This debit payment mechanism is used most commonly among oil companies and their retail distributors. The CCD/CCD+ debit transaction set is the predominant corporate payment transaction set. It is unfortunate that ACH and Federal Reserve statistics are not disaggregated enough to distinguish the intercompany from the intracompany uses of the CCD/CCD+ debit transaction.

The number of corporate payments made by the government to the private sector is shown in the table. Numbers were provided by the U.S. Treasury.

c. Financial EDI: Data Formats and Network Issues

Corporations have a variety of data formats at their disposal with which to make electronic payments. Exhibit VII-26 lists the data formats used to accomplish the transactions specified in Exhibit VII-24.

EXHIBIT VII-26

Data Formats for Payment Information

Parties	Transaction	Data Format
Seller to buyer	Invoice	X12 810, TDCC 110, 210,310,410 UCS 880, 882, 883 or proprietary format
Buyer to buyer's bank	Payment instructions	X12 820
Buyer's bank to seller's bank	EFT	Fedwire, SWIFT, CHIPS, ACH (CCD, CCD+, CTP, CTX)
Seller's bank to seller	Remittance advice	X12 820, 823
Buyer to seller	Purchase order	X12 850

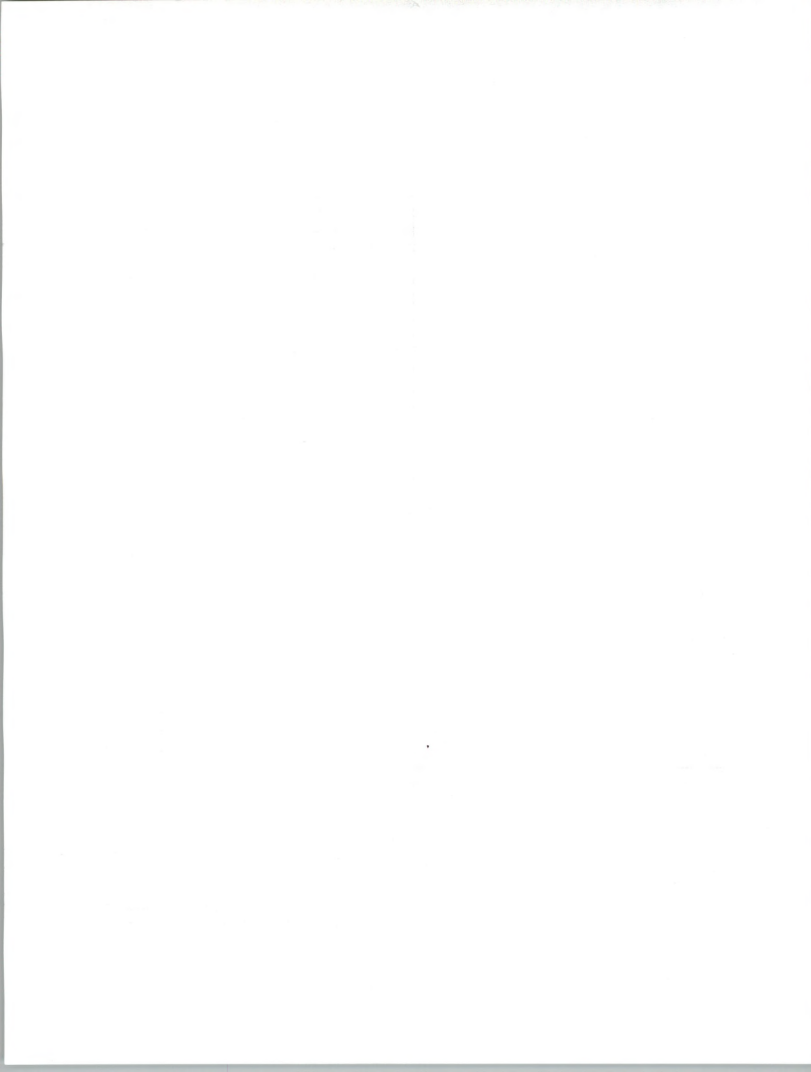

Each format can be used as a crediting mechanism (the buyer initiates the funds transfer) or a debiting mechanism (the seller initiates the funds transfer after receiving preauthorization from the buyer to do so).

At this time, the predominant electronic payment formats are the CCD and CCD+. In a single month in the second quarter of 1990 on the Cal Western regional ACH (San Francisco, CA), 829,000 CCD/CCD+ transactions were made, 886 CTPs were made, and only 11 CTXs were made.

The primary distinction between these different formats is the amount of text that can accompany the transmission explaining what the payment is for (the remittance data).

The CCD+ has room for an addendum of 80 characters for this remittance data.

The CTX format is designed to have up to 5,000 characters of remittance data in a variable-length design. Unfortunately, only about 100 U.S. banks (out of 17,500) can process the CTX format. Only a few experimental uses of the CTX are in operation at this time (such as Sears and Levi Strauss). The CTX format uses the ANSI X12 syntax. It is used in conjunction with the ANSI X12 820 payment instruction/remittance data transaction set.

The ACH network, composed of a variety of regional, Federal Reserve, and single large bank networks, is not sufficiently robust to handle a large amount of data.

Intricacies that prevent banks from becoming full-fledged financial EDI service providers include the following:

- Not all banks can originate or receive electronic payment data transmissions
- The ACH was not built to handle volumes of data beyond funds transfer data in which data transmissions are made in small message units. Consequently, the remittance detail that accompanies a payment is, in most cases, being diverted over third-party networks and delivered to the seller/payee to be matched up with the funds transfer acknowledgment from the bank.
- A NACHA survey shows that corporations want the remittance detail to stay with the funds transfer. However, the ACH and bank-premise processing infrastructure does not yet exist to fully support this.

A large opportunity exists for software vendors to supply banks with financial EDI software so that banks can provide financial services to their corporate clients.



Exhibit VII-27 lists the leading bank software vendors and their products.

EXHIBIT VII-27

Leading Financial EDI Software Vendors

Company	Target Markets	
	Corporations	Banks and Financial Institutions That Offer Payment and Collection Services to Corporations
Maxxus Inc.	✓	
Interchange Systems Inc.		✓
Stockholder Systems Inc.	✓	✓
EDS Payment Services	✓	✓
National Systems Corporation		✓
Shared Financial Systems	✓	✓
National Data Corp.		✓
GE Information Services	✓	✓

2. Factoring Services

Factoring is a centuries-old banking practice that is used by a handful of specific industries, most commonly in apparel manufacturing, and in situations where a manufacturer sells directly to a retailer.

To minimize risk to the manufacturer and to alleviate the potentially huge inventory capital requirement of the retailer, a bank will act as an intermediary. The bank will buy the receivables of the manufacturer at a discount and administer collections from the retailer. The discount at which the bank buys the manufacturer's receivables is determined by the bank's credit-worthiness rating of the retailer.

EDI plays a potentially enormous role in the factoring business. First, factoring clients (the manufacturers who are selling their receivables) can transmit EDI invoices to the bank. Bank collections from retailers and payments to manufacturers can be made using the ACH. Also, banks could collect POS data from retailers to determine credit worthiness.

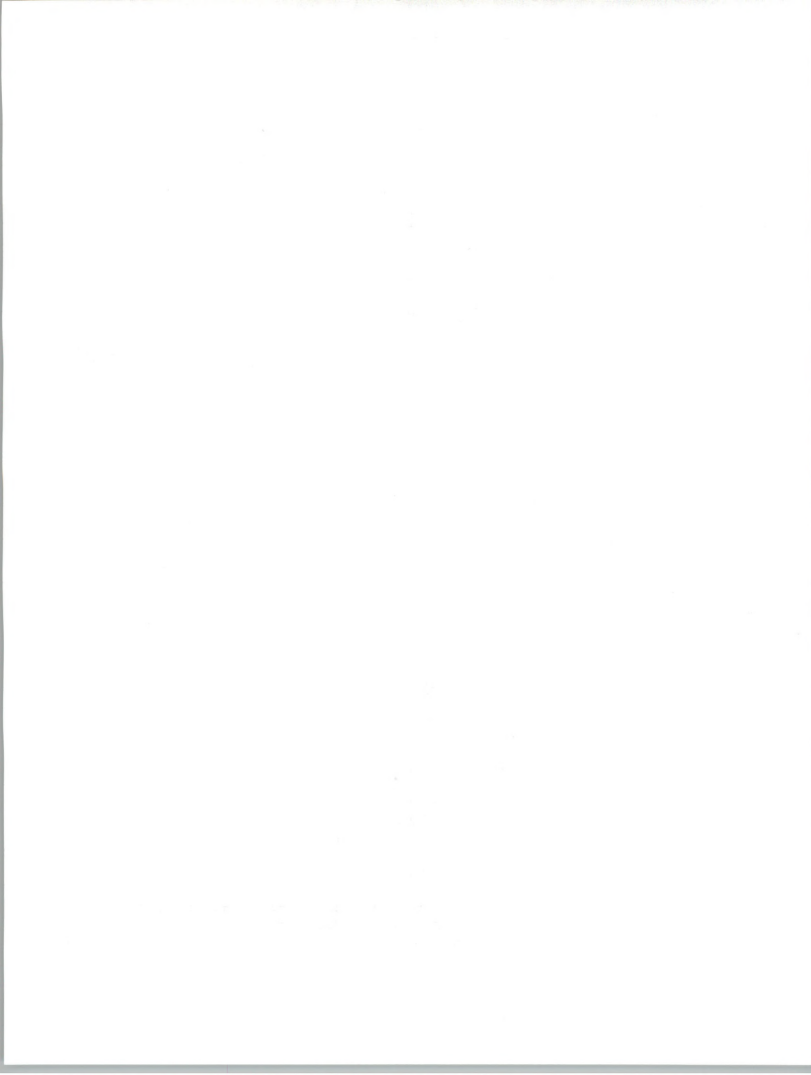

- Levi Strauss has begun a factoring program with its banks and retailers. It uses First Chicago as its factor bank.
- Citizens and Southern Corporation (Atlanta, GA), the nation's second largest factoring bank, has begun an EDI-based service for its factoring clients. Citizens and Southern uses the Translator**MVS* product of Sterling Software as its platform for receiving invoices from its clients.

3. Equipment Leasing

Although not necessarily a service of a bank, leasing is a method of finance. Leasing intermediaries are often wholly owned subsidiaries of large corporations (such as Marriott, or Ford). Leasing fundamentally affects the tax and financial posture of companies and is therefore an important area within finance. EDI is being applied to the transactions involved in leasing.

Price Waterhouse is working with Texaco to develop application software that manages the lease/purchase of capital equipment. The software will incorporate EDI and X12 formats to interconnect the various parties involved in leasing. In addition to EDI translation and communication functions, the application involves extensive data base functions. Key objectives of the application are to maintain a history of all transactions involved in the lease and providing management with tools to compare and evaluate lease/buy options (given the multitude of financial and tax variables).

Texaco has identified lease/buy software as a potentially lucrative market and is considering commercializing this software as a product. Texaco conceived the idea and has invited Price Waterhouse to be consultants on the project. Price Waterhouse is helping Texaco design the software and also define/measure the market for it. The software is going by the name of L-PITS—Lease/purchase information tracking system.

Texaco will initially use the software for the leasing of automatic data processing equipment, but the system is designed to handle any kind of capital equipment. Eventually, Texaco plans to use it for the leasing of oil tankers, pipelines and supplies, automobiles, and other items.

The life cycle of leased equipment consists of a long string of transactions among different parties. Typically, three parties are involved: the vendor of the equipment, the lessor (who owns the equipment and leases it out) and the lessee (the user of the equipment who leases it from the lessor).

A commercial lease transaction begins in the same way as a purchase transaction. The buyer/lessee sends out requests for bids, specifications or a purchase order to the equipment vendor. On receiving bids from

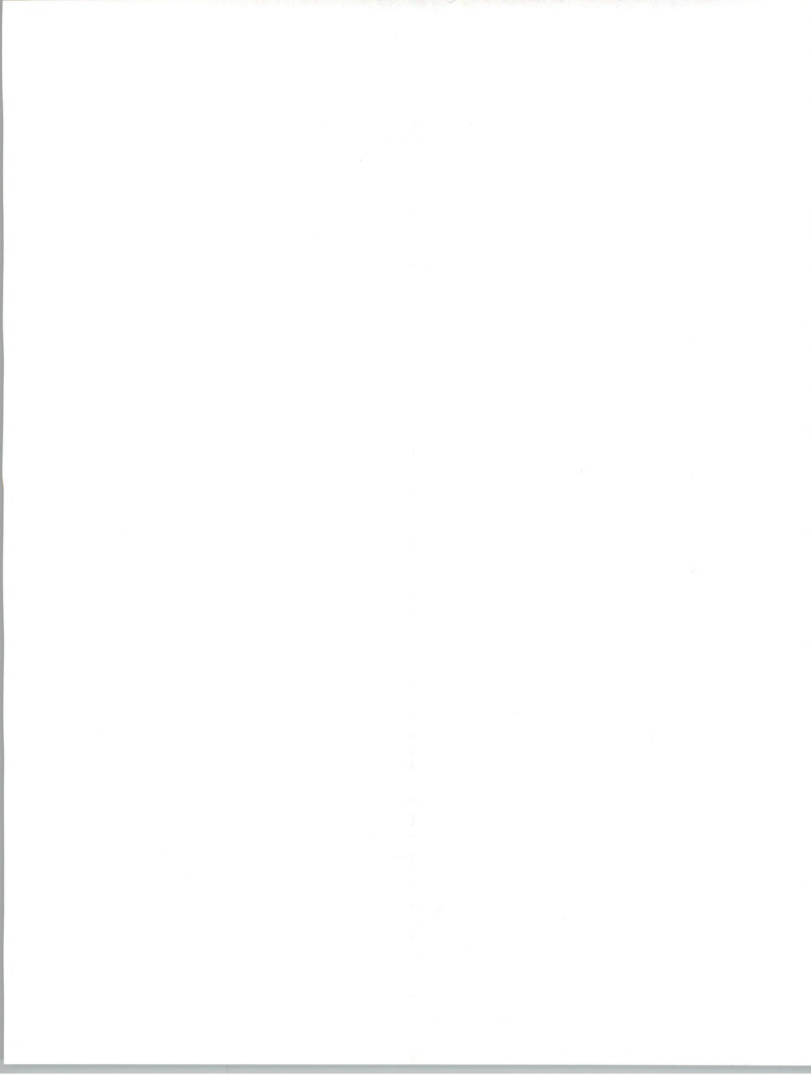

vendors, the buyer/lessee decides if it should lease or buy. If it decides to lease, then it must solicit bids from leasing companies to act as its lessor. Using EDI to solicit bids improves productivity. With one punch of a button, an RFP can be broadcasted to many leasing companies.

After the lessee has identified and contracted with a lessor, it must communicate to the vendor that it will not buy but will seek a third party from whom it can lease the equipment. The lessee then transfers its purchasing terms over to the lessor with a document called "assignment of buyer rights." Texaco is considering proposing that this document be given an official X12 standard. Sometimes the lessor may want to sell the lease to another leasing company or financial institution. This "reassignment of the lease" may also be enacted via EDI and be given its own official X12 format.

When the lease expires, more transactions are needed to cover the three options of the lessee: to terminate the lease, to extend it, or to buy the equipment outright from the lessor.

Texaco's lease application requires that some 35 documents be exchanged between lessee, lessor, and equipment vendor. Twenty of these will use EDI formats.

Documentation must be maintained for the life of the equipment, including such things as tracking events, terms and conditions, and management information. The software will modify some existing X12 transaction sets, propose new ones, and work in conjunction with extensive data base capabilities. Electronic mail will probably be used for nonstructured textual documents such as contracts.

Exhibit VII-28 lists leading users and vendors of financial EDI services.

4. Mortgage Banking

Members of the mortgage banking industry have identified EDI as a powerful tool for reducing the vast and redundant paperwork that marks the mortgage business.

Hundreds of paper forms are used in mortgage banking, many of which are rekeyed at different organizations several times, leading to a high error rate and delays. These forms originate from the residential mortgage loan application. The mortgage banking industry chose the loan application transaction as the logical starting point for an EDI transaction.



EXHIBIT VII-28

Leading Users and Vendors of Financial EDI**Leading users of financial EDI**

- General Motors
- Sears/Levi Strauss
- R.J. Reynolds
- Coors
- Provigo (Canada)

Leading bank suppliers of financial EDI

- First National Bank of Chicago
- Security Pacific Bank
- Royal Bank of Canada
- Harris Trust and Savings Bank
- First Interstate Bank
- Mellon Bank
- CoreStates Financial Corp.
- First Wachovia
- National Bank of Detroit
- Northern Trust Bank
- Bank of America
- Continental Bank
- Chase Manhattan
- Manufacturers Hanover
- Citizens and Southern Corporation

Capturing the loan application once in electronic form would allow the industry to move the application among the various banks, insurance and government agencies that sell, resell, regulate, and provide services to the mortgage. Deed searches, appraisals, credit reports, and mortgage insurance could be requested and appended to the application information.

Information could be clarified and formatted at its source and transmitted quickly and accurately without rekeying. Real dollar savings and improved customer service would be the result.

In 1984, seven mortgage bankers launched an experimental electronic mail network for communicating mortgage-related messages. The network was called ECHO and is operated by the Mortgage Banking Service Corporation (Washington, D.C.). The corporation developed PC-based software called ECHO-LINK for users of the network.

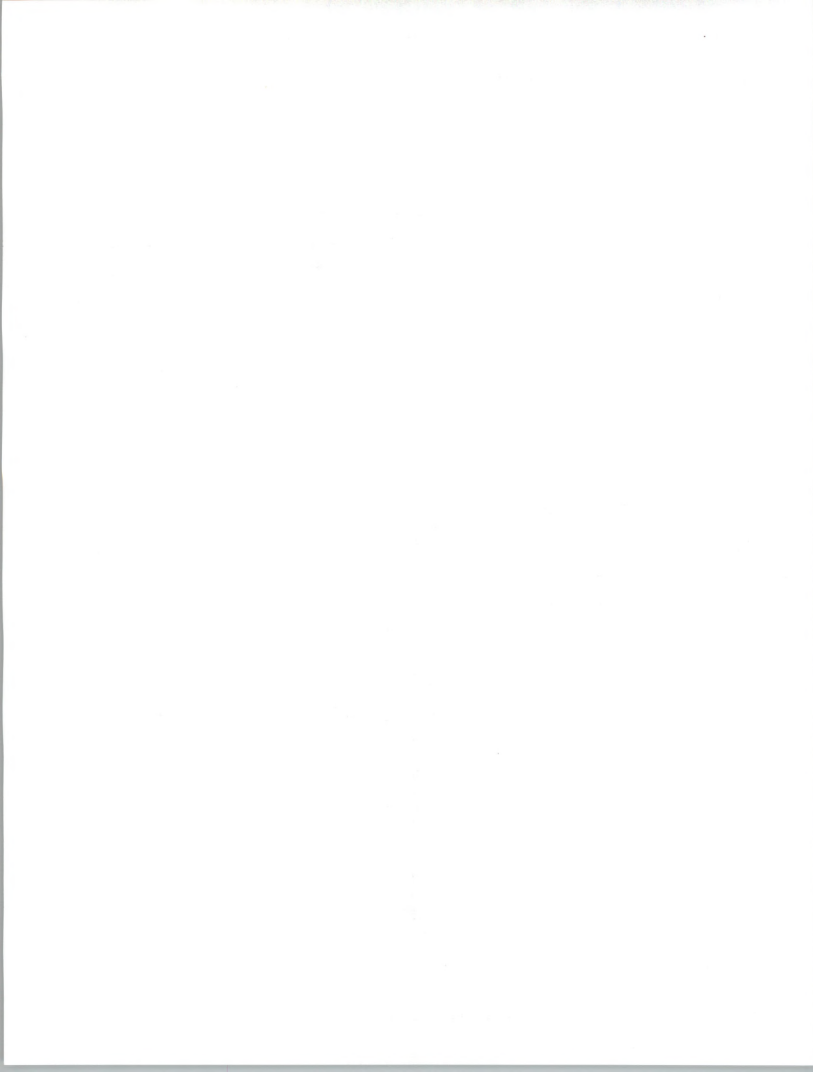

ECHO has since expanded its services to include on-line, interactive communications services supplying up-to-the-minute access to mortgage-related data bases.

The ECHO network brings lenders, vendors, and government agencies of the mortgage lending industry onto a common network. Thousands of electronic messages in the form of mortgage insurance certificates, rate sheets, HUD statement of account letters, and loan registrations are transmitted every day across the ECHO network.

Hundreds of on-line sessions are initiated via links into data bases accessing HUD mortgage letters and regulations, pending state and local legislation, and financial and travel-related information services.

In 1987, a Data Standards Task Force was formed and sponsored by the Mortgage Bankers Association of America. The Task Force joined ANSI X12 and began work on X12 transaction sets for the mortgage banking industry.

The Task Force is working on transaction sets for loan applications, credit order requests, and mortgage insurance requests.

In late 1989, the Mortgage Bankers Service Corporation expanded the ECHO-LINK software with a new product called ECHO-Matrix. ECHO-Matrix provides telecommunication facilities and supports the X12 standards being developed by the Mortgage Bankers Association Data Standards Task Force.

Features of ECHO-Matrix software include:

- Access to all types of computer and networks
- An electronic mail editor
- An indexing system to store messages by subject, category, sender, or date
- Ability to customize screens and forms
- Ability to use customized screens to order generic mortgage services from other parties, such as credit reports, appraisals, flood and title insurance, foreclosure services, etc.

Features of the ECHO network:

- Public bulletin board service
- ECHO-to-fax capability



- Government application support: FHA/CLAS electronic access to FHA case numbers and appraiser assignments; OTMIP receipt and correction of HUD Statement of Account Letters; and EVACOMM Acquisitions, VA property conveyance for the Houston VA office
- On-line data bases: Statewatch (real-time search of pending legislation), INFORM (data base of HUD guidelines such as mortgagee letters and updates, direct endorsement handbook), Dow Jones News/Retrieval, and the official Airline Guide.

An ECHO user might check his/her ECHO mailbox for messages from HUD on a particular case assignment, or review a loan registration from a correspondent, then dial directly into a mortgage insurer's computer system to check the status of his loans. By choosing another menu option, ECHO-Matrix could assist the lender in requesting a credit report, or possibly even reviewing a borrower's credit record while on-line. A quick check of the HUD data base maintained by the Mortgage Bankers Association of America (MBA) could confirm the release of a new mortgagee letter, and a word search of "appraisals" through the MBA's state legislative services would offer a quick synopsis of any state contemplating new regulations on that topic.

EDI users or potential users in mortgage banking are the 957 members of the Mortgage Banking Service Corporation, including the Federal Housing Authority (FHA) and the Federal Home Loan Mortgage Corporation (FHLMC).

5. Insurance

The insurance industry is subdivided into the life, health, and property and casualty sectors. The life insurance industry, largely oriented to individuals, has not adopted EDI in a substantial way. Health insurance is covered in this report in the section on health care. This section is related to property and casualty insurance only.

a. Property and Casualty Insurance

The property/casualty (P/C) insurance industry consists of companies that underwrite insurance which provides protection for individual, commercial businesses and others against losses of the insureds' real and personal property or losses by third parties for which the insured is liable.

- There are approximately 3,800 P/C insurance companies in the United States.
- Net premiums by P/C insurance companies increased by 2.8 percent in 1989 to \$207.6 billion.

Automobile insurance represents the single largest source of premium income for P/C insurers—almost 43%. Almost 80% of auto premiums are from individual policy holders.

Other sources of P/C premiums are workers' compensation, liability lines, homeowners' multiple peril, and commercial multiple peril. P/C insurers are increasingly underwriting accident and health insurance.

IVANS is a network for independent insurance agents and carriers who sell insurance through agents. It primarily consists of property and casualty agents and carriers, although some life and health carriers are members (and sell life and health insurance through the network). Founded in 1983 by a consortium of independent insurance carriers, IVANS uses the IBM Information Network and the Sears Communication Company network (both are SNA-based).

Property and casualty insurance sold by independent agents/carriers accounts for slightly less than 50% of all P/C insurance sold in the U.S. The predominant share is sold directly by insurance companies using their own agents (such as State Farm, Allstate, and Nationwide). Independent carriers include Aetna, Hartford, Cigna, and Farmer's Fund. Of all the P/C insurance premiums sold through independent carriers, IVANS accounts for approximately 75%. There are about 40,000 independent agents; IVANS will have approximately 12,500 (31%) by the end of 1990.

IVANS provides a variety of applications for these agents and carriers.

- Transmission of new applications to carrier company
- Changes/endorsements to policies
- Claims
- Inquiries on billings
- Inquiries on status of application review
- E-mail
- Access to service provider data bases (such as Equifax' driving record data base)

These services are provided in both batch and interactive modes.

IVANS offers internal network service connections to insurance companies to connect headquarters with branch offices.

Of the total volume of data traffic over IVANS, interactive makes up slightly over half. Batch now makes up approximately 18% but has grown 102% from 1989 to 1990.

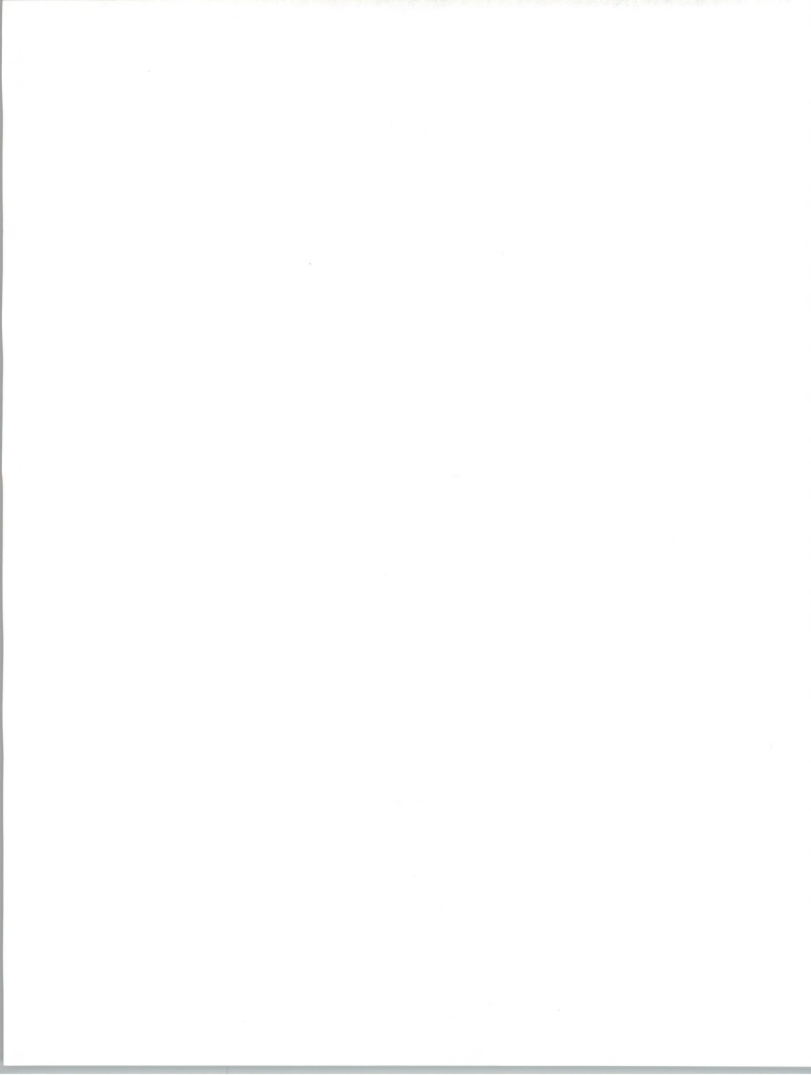

Only in the batch area are standards applicable. In this area, proprietary intercompany documents are still used. However, the ACORD standard is used also.

Exhibit VII-29 shows the gross revenues IVANS has received from users (calculated using the gross standard prices set by Sears and IBM).

EXHIBIT VII-29

IVANS Revenues			
Year	\$ Millions		
	Total	IBM	Sears
1989	16.1	15.2	0.9
1990	20.3	18.4	1.9

IVANS revenue growth 1989-1990: 26%

b. Health Insurance (see Section R, Health Care)

c. Advanced Services

Real-time/interactive sessions are the dominant data transmission method on IVANS. The main data base applications are the driving record data base and other data bases normally available through IBM's Information Network. Electronic payments are not being used.

N**Government**

Similar to the banking industry (which is both an EDI user and a service provider) the federal government is both EDI user and facilitator/regulator.

The federal government uses EDI for a variety of purposes:

- Procurement of supplies for civilian governmental functions (e.g., the General Services Administration)
- Procurement of supplies and equipment for military functions (e.g., Computer-Aided Acquisition Logistics Support)
- Procurement of private sector transportation services
- The collection of revenues (e.g., the Internal Revenue Service)



- The disbursement of funds to vendors (e.g., Vendor Express)
- The collection and processing of data for regulatory purposes (e.g., Customs, Environmental Protection Agency)
- The movement of data among government agencies (e.g., tax data)

The government also sets policy concerning EDI, including:

- Encouraging, through the Small Business Administration, the adoption of EDI
- Setting EDI guidelines for all government agencies
- Passing laws on audit procedures for electronic systems, which affect private-sector EDI users
- Determining how taxes can be paid electronically
- Determining to what degree the Automated Clearinghouse will move non-funds data

The federal government has close to 100 EDI programs in operation, 70 of them within the Department of Defense alone.

Exhibit VII-30 lists the various Federal EDI programs.

- *General Services Administration.* The GSA/Federal Supply Bureau is one of the federal government's three principal procurement arms. (The Department of Defense and the Veterans Administration are the other two buying agencies of the federal government.) In 1989, it purchased a total of \$8.5 billion worth of merchandise—everything from office supplies to automobiles—for federal government agencies throughout the world.

Currently, the GSA uses EDI with 24 of its vendors for approximately 7-12% of its total purchase order volume. The agency sends approximately 4,500 to 7,500 EDI purchase orders per month. Altogether, the GSA deals with over 200,000 vendors. Of these, only 20,000 are active. And of these 20,000, only 1,000 are currently capable of conducting EDI.

- *Department of Defense.* Currently, the Department of Defense (DoD) has approximately 70 different EDI projects that involve 300-400 vendors. These projects include military procurement, Computer-Aided Acquisition Logistics Support (CALs), financial EDI programs, MODELS (the military's inventory system), EUCOM (European Commissaries), fuel procurement, contracts, and Defense Logistics

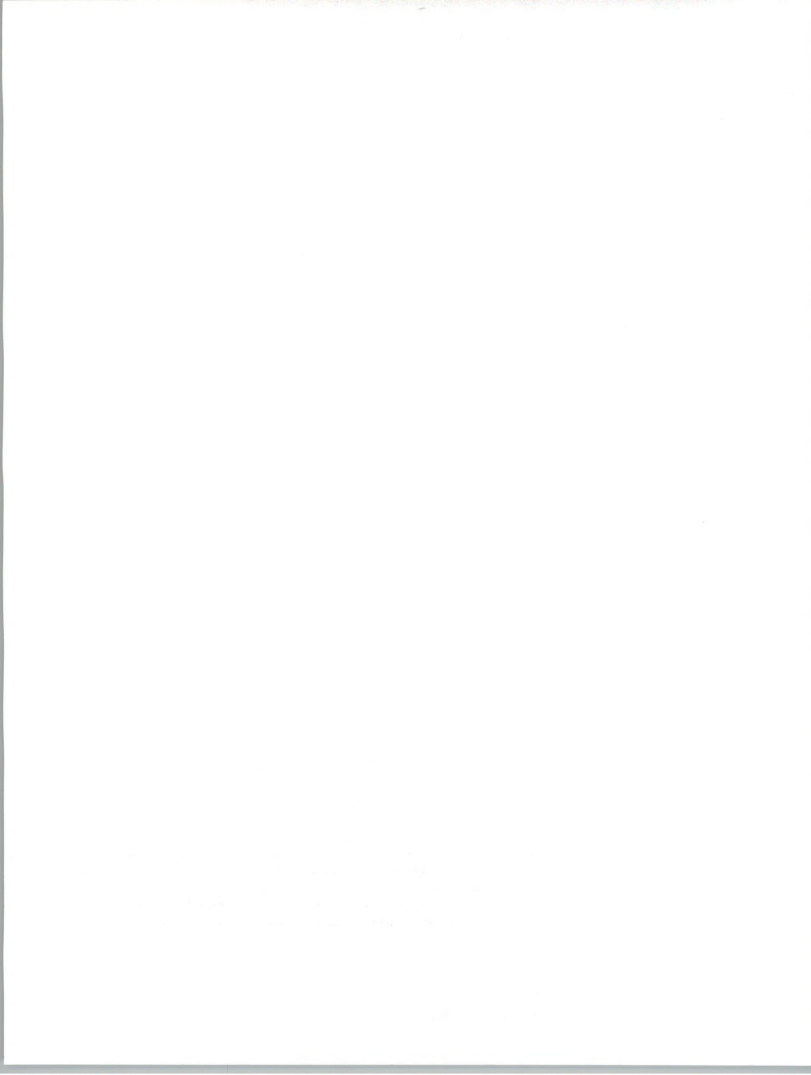

EXHIBIT VII-30

Federal EDI Programs

Government Branch	Function
General Services Administration	General procurement
Customs Service	Import clearance processing
Veterans Affairs Department	Health care claims processing
Securities and Exchange Commission	10K filing
Census Bureau	Export accounting
Department of Commerce	Export license administration
Treasury Department	Vendor Express (payments) Electronic tax filing
Transportation Department	Transport tariffs
Department of Defense	70 programs Equipment procurement Food procurement (commissary) Transportation procurement

Agency transportation programs. Lawrence Livermore National Laboratories (Livermore, CA), a DoD thinktank, is responsible for integrating these programs into a single system/network. The LLNL plans to use AT&T minicomputers (3B2/600s) as servers/gateways between the different applications.

- *Computer-Aided Acquisition Logistics Support (CALs)* is a set of information technology standards adopted by the Department of Defense to standardize all digital information necessary to design, manufacture, operate and maintain weapon systems purchased by the armed services. EDI, in the context of CALs, involves the automated formulation of digital data for such documents as specifications, equipment designs, requests for quotes, purchase orders, operational documentation, servicing records, and the like.



- *DoD commissaries.* The commissaries of the Army, Air Force, Navy, and Marines sold approximately \$10 billion worth of goods in 1989. The commissaries buy from approximately 21,000 suppliers. The Army and the Air Force combined maintain approximately 17,000 retail or customer outlets, with about 300 department store-sized exchanges. The Army/Air Force Exchange Service (AAFES) is implementing two automation projects that involve EDI: the Store Automation Project and the Integrated General Ledger Accounting System. Coopers & Lybrand is the systems integrator of the project.
- *U.S. Treasury Department.* The Department's Vendor Express program automates government agencies' bill paying. The Treasury pays government vendors or collection intermediaries via the Automated Clearinghouse, primarily using the Cash Concentration and Disbursement (CCD) format (because most financial institutions can receive it) and also via the more sophisticated Corporate Trade Exchange (CTX). The Treasury makes approximately 77 million payments per year. So far the Vendor Express accounts for only three million of them and \$30 billion per year.

The Treasury Department is also the superordinate federal office overseeing the Customs Agency, and thus is responsible for the Automated Commercial System for the international trade community (see Transportation section).

- *The Environmental Protection Agency.* The EPA is chartered to control and abate pollution in the areas of air, water, solid waste, noise, radiation, and toxic substances. It consists of numerous subagencies, programs, and statutory powers.

The EPA is investigating the use of ANSI X12 messages to create filing forms for its regulated constituents. The forms would be processed by appropriate EPA systems and kept in on-line data bases for queries relating to future EPA and other government functions, such as Customs clearances and tax purposes.

- *Internal Revenue Service.* The IRS is adopting EDI in two main areas: electronic filing of taxes and the moving of tax-related data among governmental agencies.

In addition, state governments are initiating programs to allow corporations to file state taxes electronically.

State and federal agencies—particularly the Social Security Administration, the Department of Education, and the many state tax administrations—regularly request tax information on individuals and corporations from the IRS. The IRS is examining X12 transaction sets as a way to move this data among agencies.

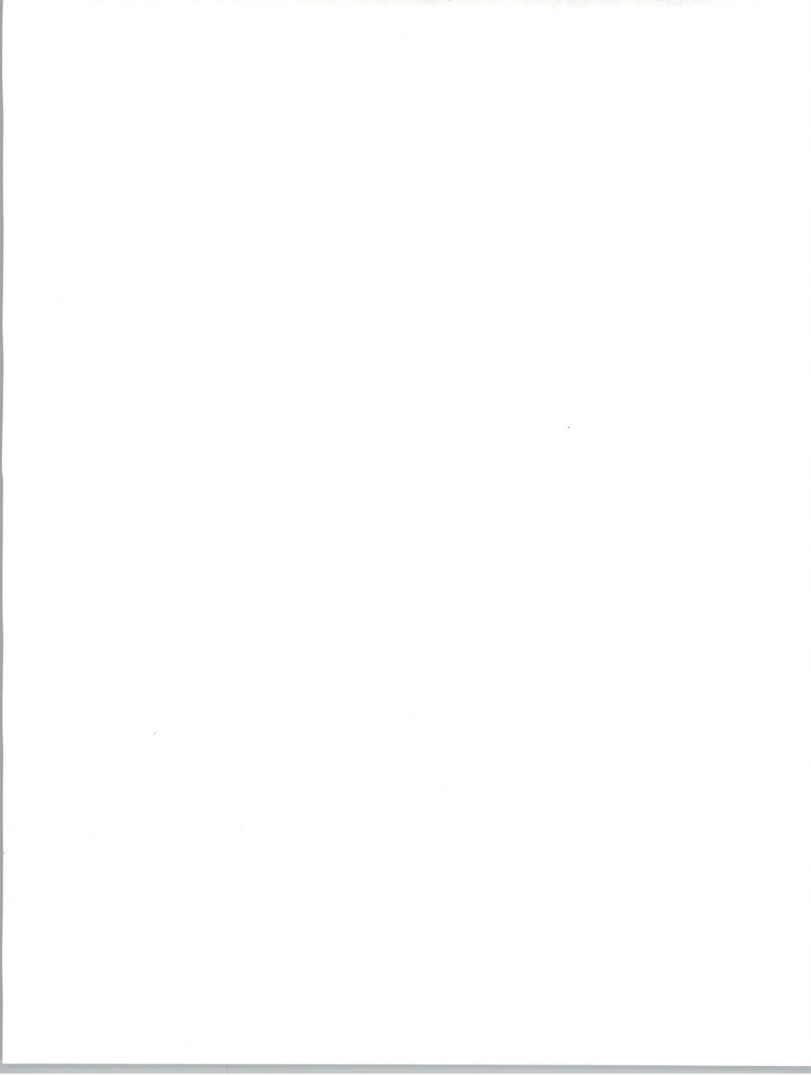

These agencies will use this data to block refunds to individuals who are delinquent in other government-mandated payments (such as child-care payments or student loans). The IRS will divert the individual's refund monies to the agency that has a legitimate claim.

- Other government involvement in EDI, covered elsewhere in this report, includes the U.S. Customs Service (covered under Transportation) and Health Care Finance Administration (covered under Insurance).
- *Electronic Benefits Transfer (EBT)*. The U.S. Food and Nutrition Service (FNS), part of the Department of Agriculture, administers the program by which 2.5 billion food stamps worth \$13 billion are issued to 20 million people, used in 225,000 food stores and processed by 10,000 banks each year.

The FNS is establishing programs for the electronic distribution of food stamps, a form of electronic benefits transfer, or EBT. Limited-scope programs are in operation in Pennsylvania, Maryland, New Mexico, Minnesota, and Iowa. Other varieties of electronic benefits transfer are being explored with welfare and Medicaid payments.

Households are issued plastic magnetic-strip cards. In the grocery line, the card is run through a point-of-sale terminal, a personal ID is entered and money is transferred from the customer's food stamp account to the grocer's account in a host computer at a regional site.

Exhibit VII-31 shows how food stamp benefits are distributed using electronic benefits transfer.

EBT can be viewed as a straightforward implementation of direct deposit. The system uses regional clearinghouse and ATM/POS networks of financial institutions.

Food stamp distribution requires multiple parties and checks and balances. By law, the benefit must go for approved food items only. Also, food stamps are issued by the federal government to states, so FNS has no direct relationship with recipients.

A nationwide system for food stamps will require many complex relationships between FNS, other federal agencies, state governments, retailers, financial institutions, hardware and software vendors, systems integrators, and providers of networking services.

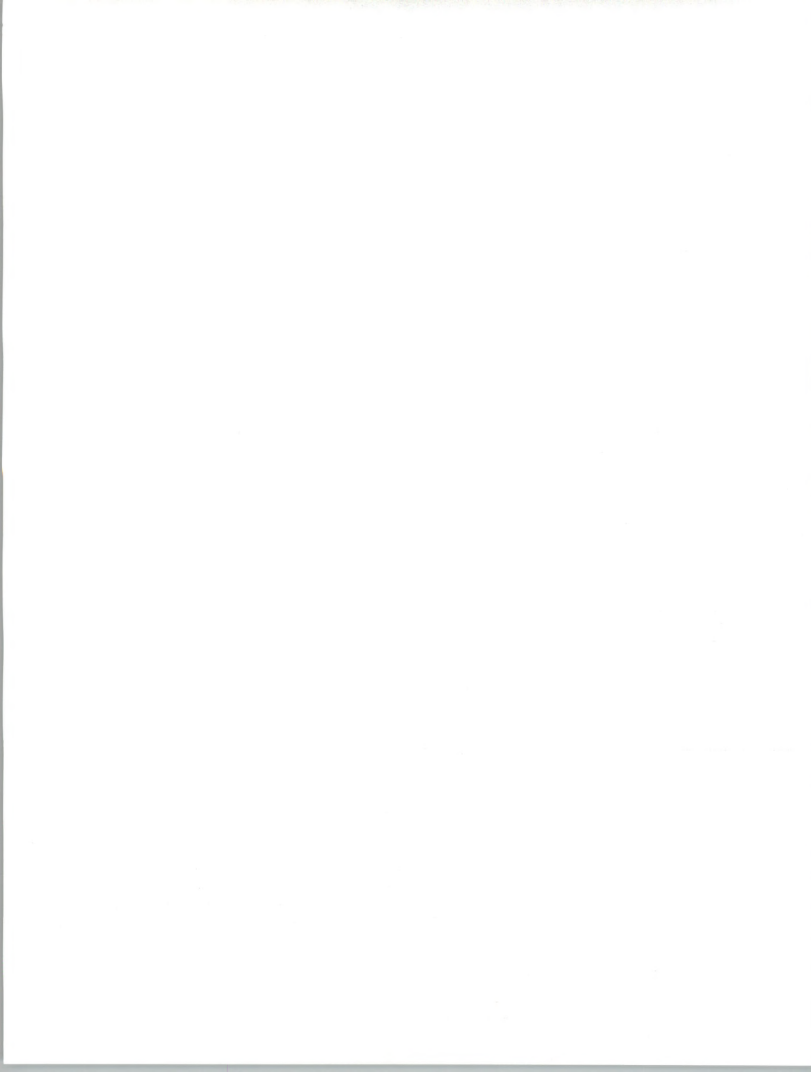
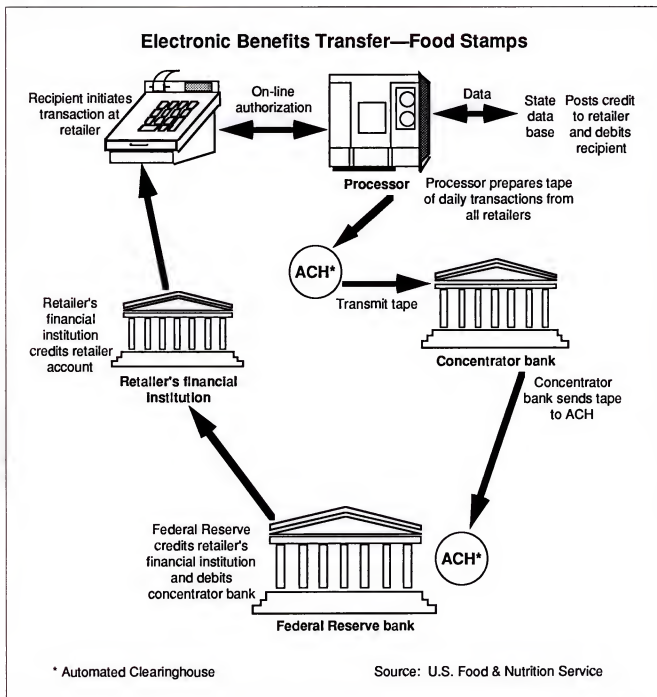
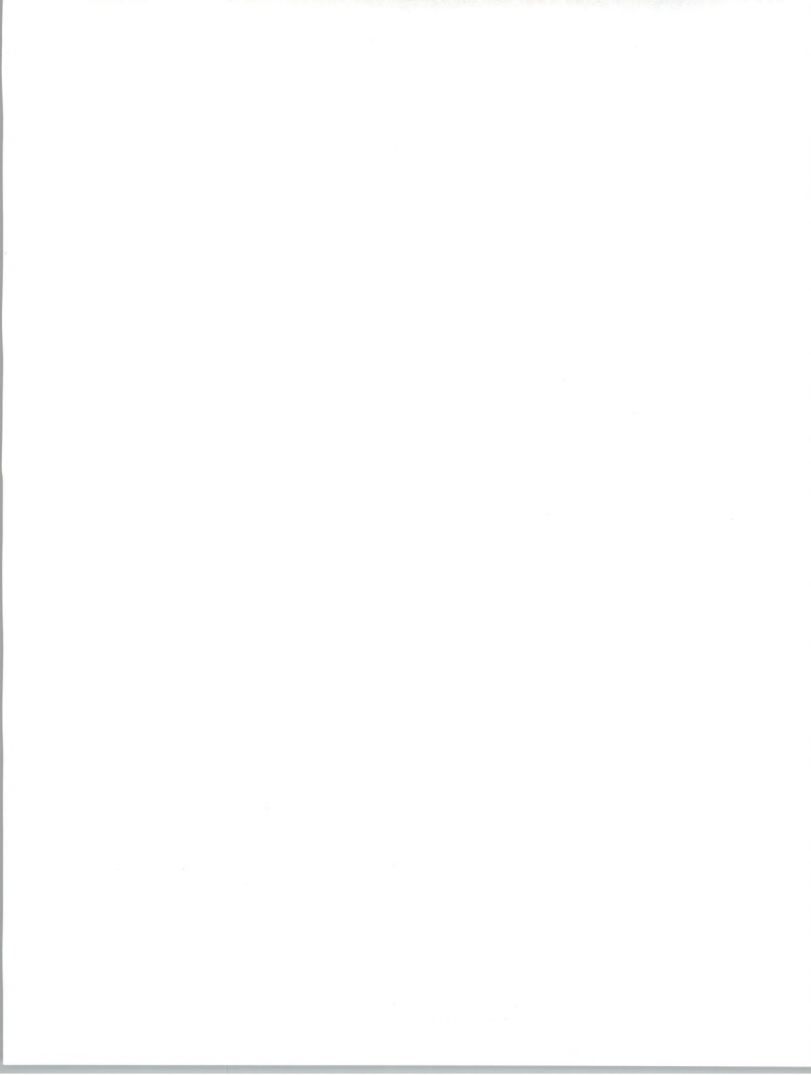

EXHIBIT VII-31



- *Small Business Administration.* The federal government is considering making loans and providing educational materials to small businesses to encourage them to adopt EDI. The resources would be made available through the Small Business Administration in conjunction with the Electronic Data Interchange Association.



O**Agriculture**

EDI between farmers and their trading partners is not potentially large.

- Government agencies (viz., the Department of Agriculture) are developing various information gathering and dissemination systems that may or may not use EDI. The Office of Management and Budget has called for wide usage of EDI throughout all branches of the federal government. This policy may impact the Department of Agriculture's design of its farm-oriented information systems.
- Food co-ops in the Midwest maintain data communications systems that potentially could incorporate EDI. At this time, none are doing so.
- EDI is used in the distribution of chemical supplies (fertilizers, pesticides) and veterinary supplies to farms. But this EDI connects manufacturers with wholesalers and retailers.
- EDI has been in use in the grocery industry since the early 1980s between food processing companies and distributors. In the last two years, direct-store deliveries to grocery markets have begun using EDI systems. Today, however, EDI between fresh produce growers and distributors is new.

Highly perishable produce requires swift hand-offs from grower to distributor to customer. Price volatility requires constant verbal communication between buyer and seller.

EDI-style purchasing of such perishable commodities that manifest hair-trigger price variations is not feasible, according to industry spokespersons.

Nevertheless, EDI invoicing (from grower to buyer) is one area where EDI is possible. (See the Bud of California example in the Grocery section.)

P**Construction**

The \$450 billion 1990 construction industry covers a wide range of building sectors: residential, nonresidential (manufacturing facilities, utilities, hospitals, railroads, commercial store and office buildings, etc.) and public works (highways, sewer and water systems, military facilities, etc.).

Due to the customized nature of construction, the EDI potential appears small. However, recent developments suggest that EDI will find a niche in the industry.



- Large engineering and construction firms are experimenting with "in the field" electronic purchasing systems that use EDI.
- Industrial companies with large facilities that have used EDI for some years for operational purposes are now investigating EDI for construction purposes.
- The Construction Industry Institute (Austin, TX) commissioned a study on electronic information systems for use in large construction projects. The study recommends ways for engineering contractors and facilities owners to use EDI during construction projects.
- The Construction Industry Institute is forming an EDI action group that will develop X12 transaction sets and industry guidelines.

EDI in the construction industry is most suitable for large-scale industrial construction projects, such as food-processing and petrochemical plants, and large-scale commercial construction, namely high-rise office buildings.

Building activity occurs not only in new construction but also in renovation and expansion. Many industrial companies are continually renovating and expanding existing facilities.

Leading the use of EDI in the construction industry are the 80 members of the Construction Industry Institute (CII). Membership is split evenly between engineering construction companies and facility owners such as petrochemical companies and utilities.

Electronic communications in construction are being spurred by a general push by large construction companies toward integration of existing information systems. Computer applications for cost estimating, project scheduling, materials management, and computer-aided design and engineering, for example, are being integrated.

Interorganizational electronic file transfers play an important role in large-scale construction projects. Many separate business entities are typically involved in construction projects: an engineering/design company, the owner, a general contractor, many subcontractors, suppliers of materials, suppliers of tools, etc. Procurement transactions are only one category of interorganizational data transfers that occur.

Approximately 60-70 transaction set types that are unique to construction have been identified by the CII. The group is most immediately interested in developing X12 formats for the following:

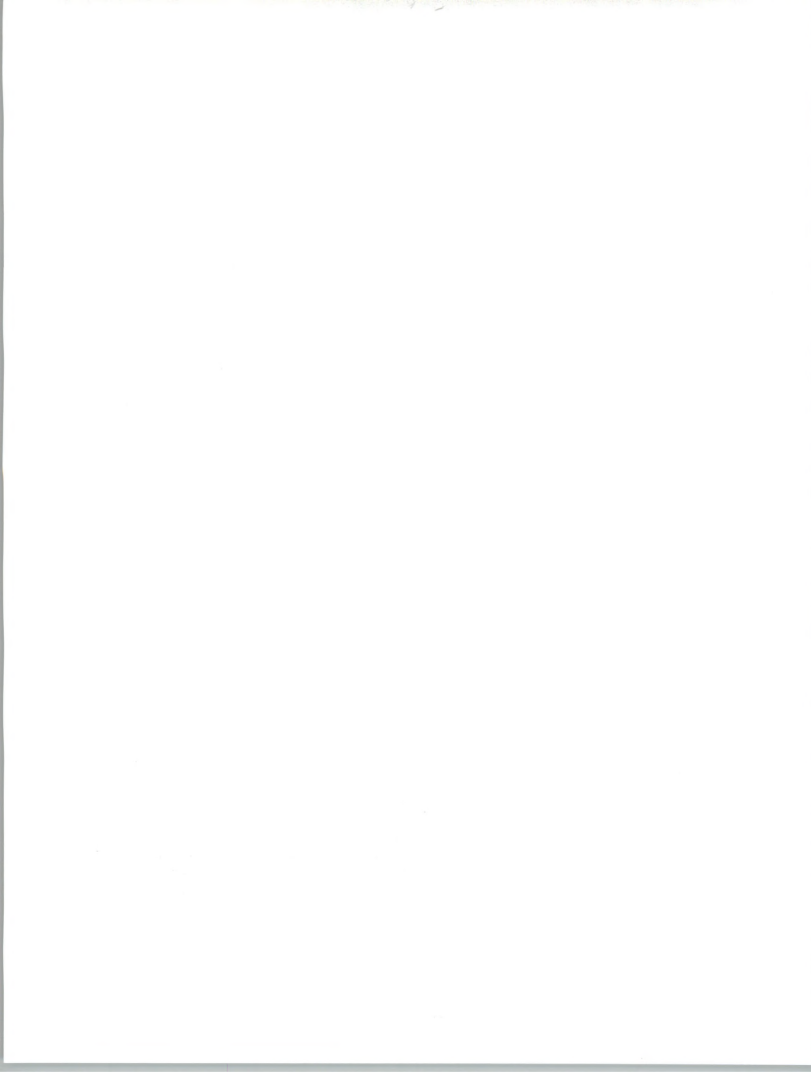

- Man-hours spent reports: time cards are sent from subcontractor to contractor and between contractors.
- Quantity information: design specifications for quantities of materials needed (concrete, steel, square footage of concrete forms, lumber, piping, etc.). This information is used in the bid process and is transmitted between engineering firms and contractors.
- Inspection reports sent between contractors and government officials.
- Material receipt statements sent from suppliers to subcontractors, and from subcontractors to general contractors when supplies are delivered.
- Computer-aided design (CAD) files sent between the designing company and the building contractor; and between building contractor and subcontractor. Eventually, design plans and specifications are stored by the client for future repairs, servicing and facility expansion.
- Procurement transaction sets sent between contractors and material suppliers. Although a majority of a project's supplies are procured in a lump quantity via a bid process, there is always a need for incremental purchases. Often these purchases are repetitive and will continue for more than a year.

1. Need for Advanced EDI Services

The construction industry is ripe for many advanced EDI services.

- A key service needed by the construction industry is to be able to move graphics files electronically.
- Payment services are reportedly in use by a few major construction companies (i.e., Bechtel).
- Real-time, on-line ordering systems are offered by some wholesalers of industrial parts, such as pipe, valve, and fitting wholesalers.

Exhibit VII-32 lists leading users and vendors of EDI in the construction trading community.

The construction industry, new to EDI, has not targeted a particular third-party network provider. However, many companies used Western Union (now AT&T) for facsimile services, particularly for the transmission of graphical material. This has led to adopting Western Union as a partner in some projects where advanced construction uses of EDI were piloted.



EXHIBIT VII-32

EDI in Construction

Total number of EDI users: 80
(members of the Construction Industry Institute)

Key Users	Specialty
Contractors: Bechtel Fluor-Daniel Kellogg Turner Stone and Webster Brown and Root	Offshore platforms, airports Petrochemical Food processing plants Office high-rise Petrochemical
Facility owners: Dow Chemical Exxon E.I. du Pont Utilities Food manufacturers	

Leading network service provider: no dominant provider

Q**Education**

Representatives from universities and school districts around the country are in the process of developing X12 EDI transaction sets.

Initial needs for transaction sets are to:

- Move student transcripts from university to university
- Move course description and college catalog information among universities
- Move student information to verify loans and scholarship applications
- Move student transcripts and health records from high schools to universities
- Move student transcripts and health records among high schools

Exhibit VII-33 depicts EDI use in education.

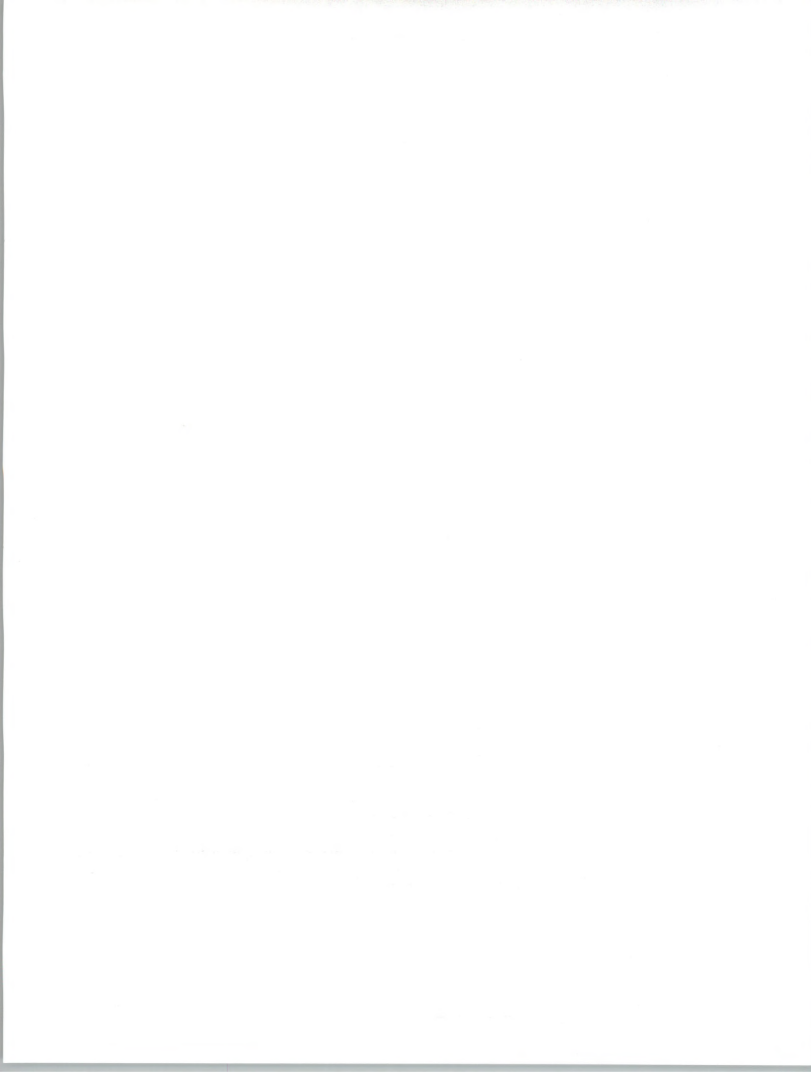
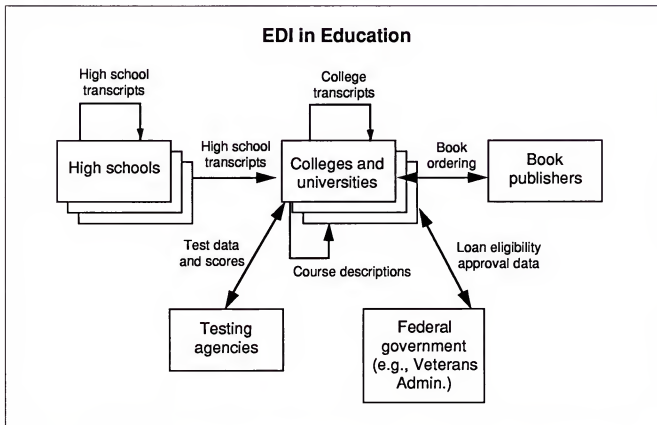

EXHIBIT VII-33



The American Association of College Registrars and Admissions Officers (AACRAO) has an EDI subcommittee that has already submitted an X12 format to DISA (the Data Interchange Standards Association, the secretariat to the ANSI X12 Accredited Standards Committee). The format allows the electronic exchange of transcripts among colleges and universities.

Also, for secondary schools, an ad hoc committee composed of members of various secondary school groups (state departments of education, municipal school districts, for example) are working on transaction sets for exchanging high school student transcripts. The committee is being financed by the National Center for Educational Statistics, an agency of the Department of Education.

The university transcript format is currently being tested by transmissions between the University of Texas, Austin and Miami-Dade Community College, Florida. The University of Florida may shortly join the test.



Since 1984, colleges and universities in Texas have been exchanging student transcripts via EDI among themselves. (Throughout the U.S. and the world, transcripts are sent via facsimile as well.) The Texas Electronic Transcript Network is administered by the Association for Higher Education for North Texas and uses the GEIS network. Formats are machine processable. Approximately 17 institutions participate in the network.

The state of Florida, too, has a network—the Florida Information Resource Network (FIRN). It supports the transmission of transcripts not only among postsecondary institutions, but between high schools and these institutions. The transcript format for FIRN—different from the Texas format—is also machine processable.

- The X12 design for a transcript transaction set is the first attempt anywhere in the country to make a format for a nationwide exchange of transcripts between institutions.
- The pilot test between Florida and Texas is made possible for the time being by having the FIRN network interconnect with GEIS.

The committee developing the standard has had to come up with a new design. The Florida transaction set has a greater number of data elements than the Texas format. Use of the Florida network by schools is entirely subsidized by the Florida Department of Education. Florida administrators who designed the FIRN format had no incentives to be economical with the use of data. With the Texas system, an institution pays each time it sends or receives data. Only essential data is sent, therefore.

Developers of the EDI data formats for transcripts may use the purchase order as a starting point because a transcript is similar in structure to a PO. Each has many line items with a value attached to each item, and each has a grand total value.

A PO has products and quantities/prices; a transcript has courses and grades. A PO has a total purchase amount, whereas a transcript has a grade point average.

In an EDI translation package, look-up tables of codes would be all that is necessary to differentiate an 850 from being either a commercial purchase order or a university transcript.

The various transaction sets proposed would contain the following kinds of information:



- Transcripts would contain courses, grades in courses, number of units, degree information, grade point average, and student name.
- An optional component of the transcripts may contain data regarding a student's standardized test scores (such as the SAT, GMAT, MCAT, TESOL). Some institutions require that test scores be sent directly from the testing institution as a guarantee of credibility. Other institutions, particularly community colleges or institutions that allow walk-up registration, see the inclusion of test scores on a transcript as a convenience.
- Loan verification information would not contain transcript information. Rather, the information would be whether the student is full-time or part-time, whether the student is making progress or not, and the student's scholastic qualifications.

EDIFACT is being considered by the committee for interchanges between universities around the world.

1. Data Base Needs

a. Course Description Catalogs

A necessary adjunct to the transcript, however, is a transaction set (yet to be designed) that would contain course description information; the kind of information found in college/university catalogs. This is needed by registration officers in evaluating a student's transcripts. For each course on the student's record, the officer reads the course description and decides how to assign credit to it equivalent to the officer's university's system.

Today, officers simply thumb through the catalog of the institution in question while scrutinizing the paper transcript that was received in the mail.

An EDI campus catalog transaction set may consist of a compound document, according to persons on the standards development committees.

Course description information would be put in X12 transaction sets. The rest of the information (admission policies, faculty information, campus description information, and the like) would be placed in the OSI Office Document Architecture (ODA). ODA supports graphics and images. The two formats would be sent together. The course description information is reserved for X12 formats because need for it is more pressing—it serves a real-world function. It needs to be developed now. The rest of the catalog can come later.



Course description is difficult, however. Capturing course information either requires long fields (for free text descriptions) or codes that identify basic elements of the course. The codes are a universal syntax to describe a course content. The code pathway is attractive because it allows transcripts to be processed by machine. However, in the end it may not be feasible.

Codifying course descriptions would require standardizing what constitutes a first-year calculus course, an undergraduate European history course, etc. With such a universal standard, institutions can cross-calibrate a student's performance in one school according to its own academic standards and requirements.

Already, admissions officers pursue a process called articulation whereby they equilibrate/calibrate curricula across institutions so that they can measure student achievement. With an articulation format, the articulation process could be done in a quantifiable, deterministic way.

In California, educational groups have developed the California Articulation Number (CAN) which describes courses. But it is not a simple task. In the ten years that the groups have been working on standardizing the syntax to describe courses, only 30 or so courses have been given a number.

b. A National Student Data Base

A centralized clearinghouse may be needed in the future when EDI exchange of student records is commonplace. A centralized data base of records could be very economical. Data bases might be developed for university catalogs, a listing of all educational institutions and their EDI capabilities, administrative information regarding data formats and transmission procedures, and possibly for student records and transcripts.

2. Case Study: University of Texas, Austin

The university, with 50,000 students, receives or sends that many transcripts plus 20,000 more high school student transcripts every year.

The university conducts proprietary EDI with a variety of agencies. With the Veterans Administration, it sends magnetic tapes of student records of those students who are going to school on the GI bill.

For the federal government's Guaranteed Student Loan program, it receives electronic lists of students who are loan recipients. The university sends back records on if and when those students left the university and therefore are obligated to pay off the loans.

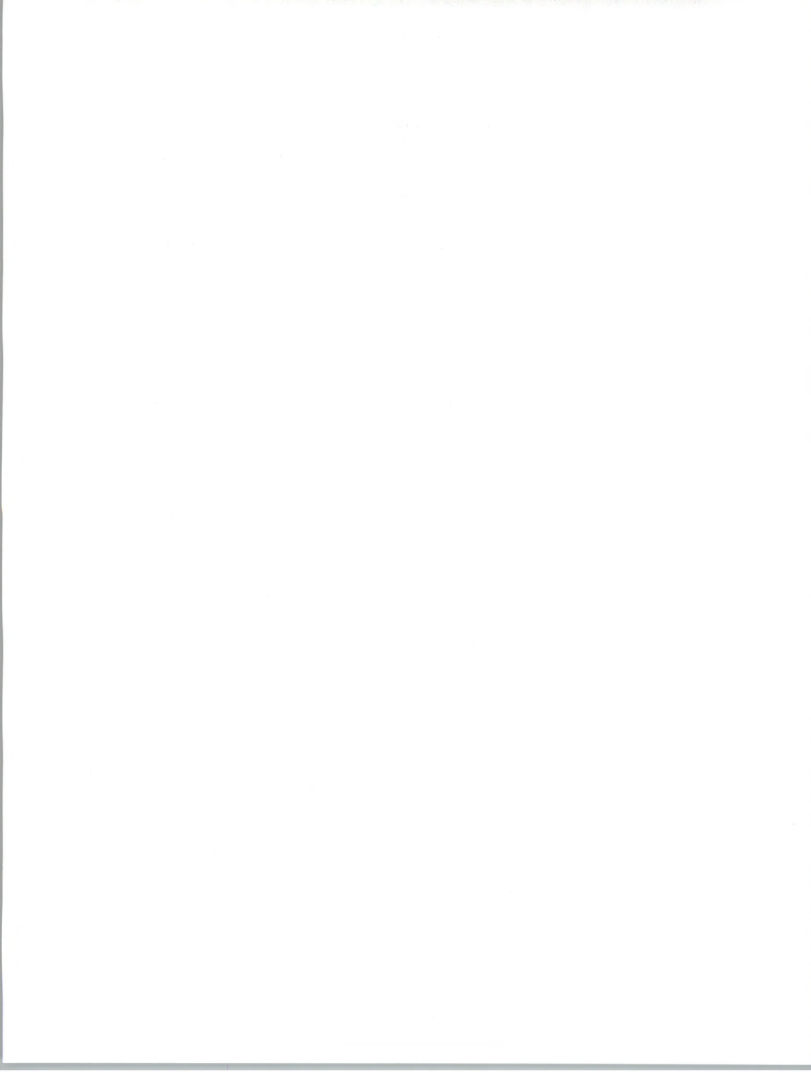

The university receives financial aid information on students (parents' tax forms, ability-to-pay information, etc.) from such agencies as the College Scholarship Service and the American College Testing Program.

The university receives test scores electronically over telecommunications lines from testing agencies.

The university's procurement department has not yet begun using EDI.

The University of Texas, Austin does not have a bookstore, so it does not use Pubnet, a proprietary format EDI book purchasing system used by many university bookstores across the nation. Also, the university does not possess oil-producing properties (as do other Texas universities). Thus, it does not participate in the Petrodex royalty distribution program.

R

Health Care

Health care is broken out as a separate category because it comprises a focused and interrelated set of service and manufacturing activities.

EDI in this economic category can be found in interorganizational transactions for procurement of pharmaceutical and medical/surgical supplies and the processing of health insurance.

1. Health Insurance

Health insurance can be looked upon as insurance companies buying health care on behalf of their customers. EDI shows up in this commercial transaction as the processing of insurance claims ("invoices" from healthcare providers to insurers for services rendered).

EDI is already established in other parts of the health care industry, such as in the ordering of pharmaceutical and medical/surgical supplies by hospitals and buying groups from manufacturers.

In late 1989, industry representatives from insurance companies, banks, insurance service providers, and the federal government formed an X12 subcommittee to develop EDI standards for health insurance.

Today, only five percent of medical insurance claims are received electronically. They are submitted in industry-defined formats.

With the labyrinth of different health care entities—providers, private insurance companies, government agencies, intermediaries for government agencies, employers, and processing/clearinghouse groups—the existing formats do not address all transactional needs. (See Exhibit VII-34.)

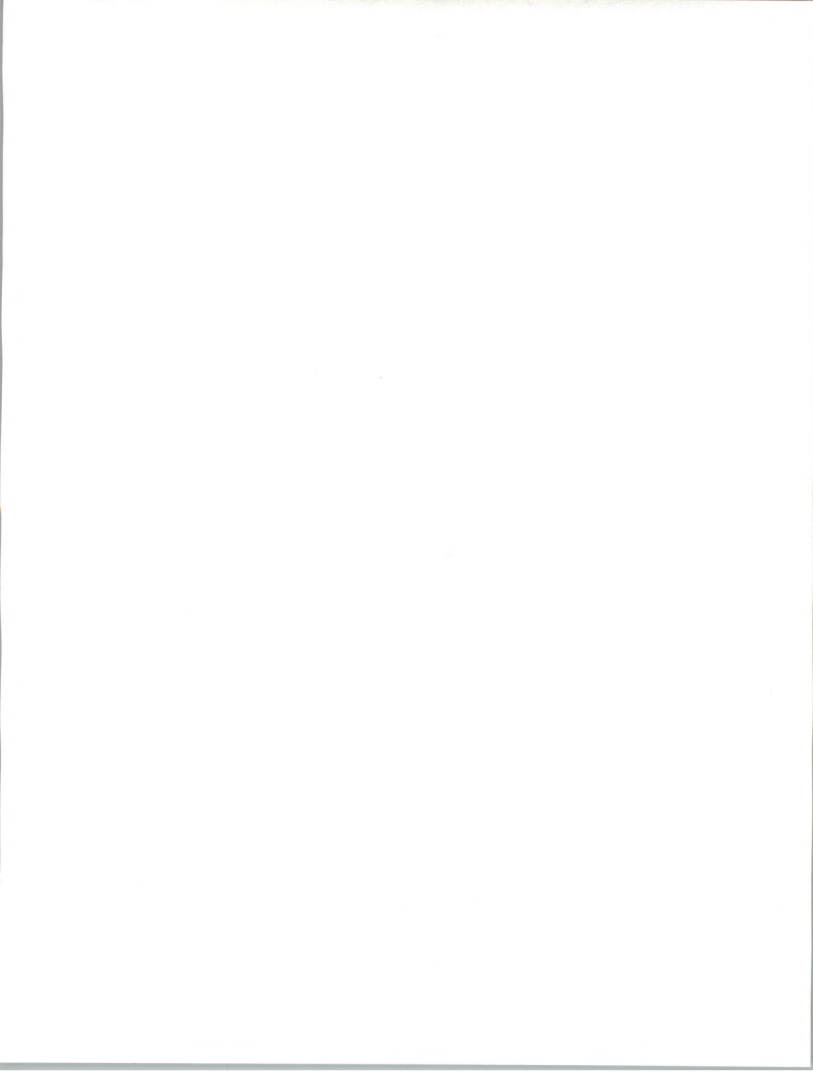
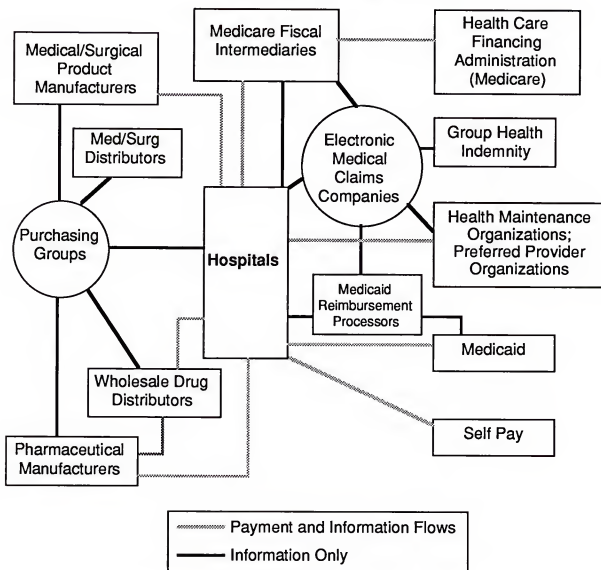

EXHIBIT VII-34

Hospital Industry Trading Partners



Courtesy of First National Bank of Chicago

Rather than add new formats where none exist, industry insiders are considering designing an integrated, coherent set of transactions based on a common data model. The new architecture would then be a part of the ANSI ASC X12 family of EDI standards, thus bringing the vital industries of health care and medical insurance under the X12 umbrella.

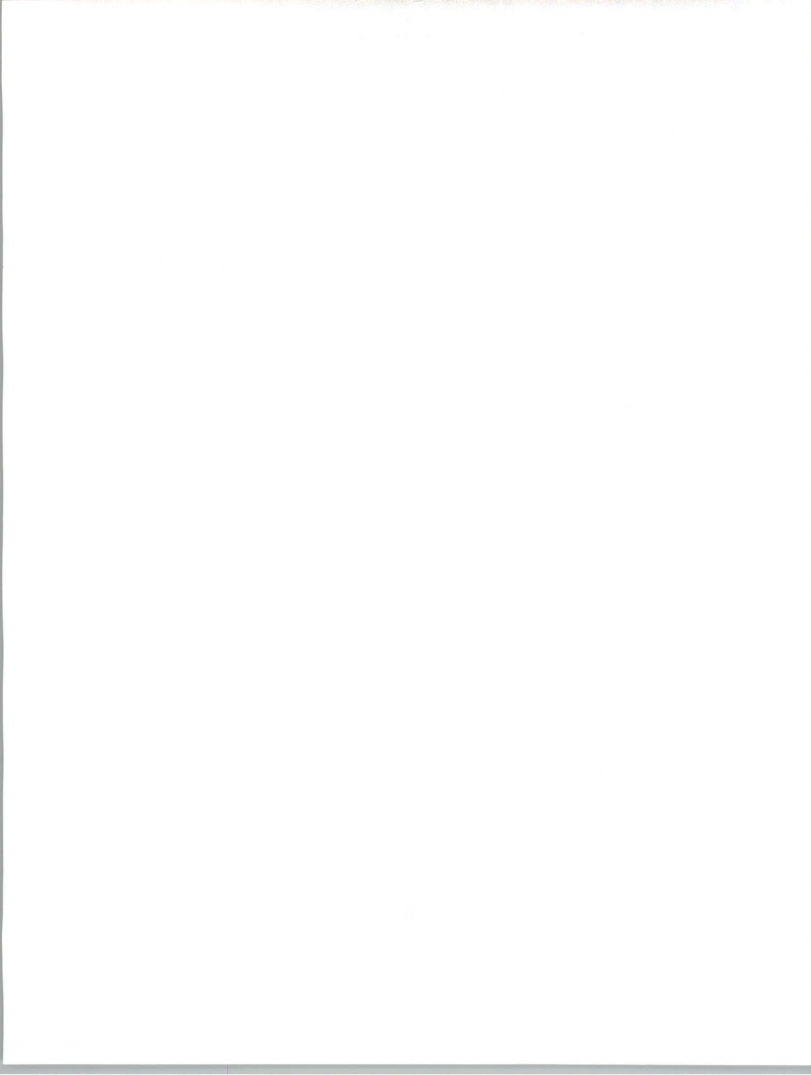

Transaction sets currently under development are:

- Enrollment and maintenance: the individual's employer transmits policy data to the insurer and the health care provider.
- Claims/billing: the health care provider requests payment from insurers for services provided to the individual.
- Remittance advice/coverage data: the insurer, using a bank intermediary, pays the health care provider with EFT; details on the individual and service provided are sent along with funds for reconciliation purposes.
- Pre-Admission Certifications: doctors notify insurers before they send a patient to a hospital, to check how much the insurer will cover.
- Referrals: doctors refer specialist doctors for specialized patient treatment. Who the doctor refers is important for claims payment. A health care insurance plan often itemizes what specialists can be used, at what rate of reimbursement. In a "managed" health care system (a health maintenance organization (HMO) or a preferred provider organization (PPO)), the patient is given a network of specialists to choose from. The patient may not be covered outside the network. For those patients not on a managed plan, specialist care will be subject to other kinds of restrictions. The referral message is important for billing purposes.

The key document is the enrollment/maintenance data set. This is how an employer registers an employee or updates the employee's coverage (adds new family members, changes coverage parameters, etc.). This document is key because it is the basis from which all transactions for claims submissions/billings and payments are made. It is the source data on the individual: who the insurer is, the employer, what benefits he is entitled to, other beneficiaries on the plan, and period of enrollment. As a result, developing an X12 format for enrollment and maintenance is the highest priority, according members of the X12 group.

Already, a handful of electronic formats exist for health care providers to submit claims.

- The Uniform Bill 82 (UB82) is used by hospitals to submit claims to government-backed insurers. Ninety percent of Medicare claims come in electronically using UB82. Many commercial insurers, however, won't accept UB82.
- The Health Care Finance Administration (HCFA) 1500 is used by individual physicians to bill insurers.

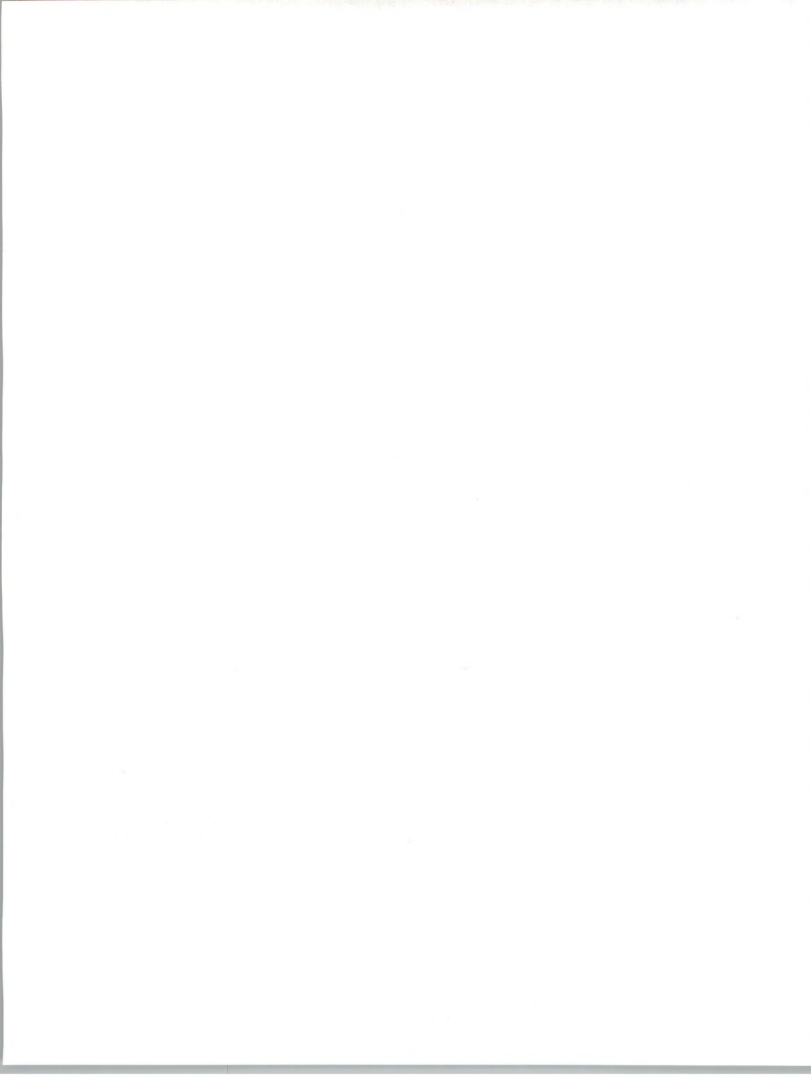

- Many hospital pharmacies submit claims (for drug prescriptions) using a real-time private third-party processor called PCS, Inc. of Phoenix, AZ.
- In submitting claims to commercial insurers, some hospitals use a claim format similar to the UB82 but with twenty more data fields. The format was developed in the early 1980s by a consortium of large insurance companies called National Electronic Information Corporation (NEIC), Secaucus, NJ. Only 5% of commercial medical claims are submitted via the NEIC method. NEIC uses BT/Tymnet (San Jose, CA) as its processor/network.

The X12 group wants to incorporate the UB82 and the HCFA 1500 as optional segments of a single X12 claims format. If the billing agency was a hospital, it would use the UB82 segment. If it was a physician, it would use the HCFA 1500 segment.

a. Electronic Funds Transfers

The biggest benefit of electronic claims submission is improvement of the cash flow at hospitals. The national average for the time between when a hospital discharges a patient and when it collects insurance payment is 70 days. Sending claims electronically reduces that period to an average of 40 days, according to users at Memorial Sloan Kettering Hospital.

Work is underway for insurance companies to pay health care providers electronically using the X12 820 payment instruction/remittance advice.

- In 1990, some health care EFT pilots will get underway. Several large insurance companies (Blue Cross and some large private companies) will pay hospital claims electronically. Also, First National Bank of Chicago and Abbott (a maker of hospital information systems) will launch Quik Link, which allows hospitals to pay suppliers electronically.
- Health care services are much more complex than the movement of physical goods. The claims remittance advice, therefore, must capture more complicated data. Today's X12 820 remittance format won't do. Currently, the 820 is unable to represent time periods and services adequately. Also, many parties are involved in health care—insurers, employers, providers, intermediaries, the government—and data fields for these parties and their addresses must be included on the remittance.

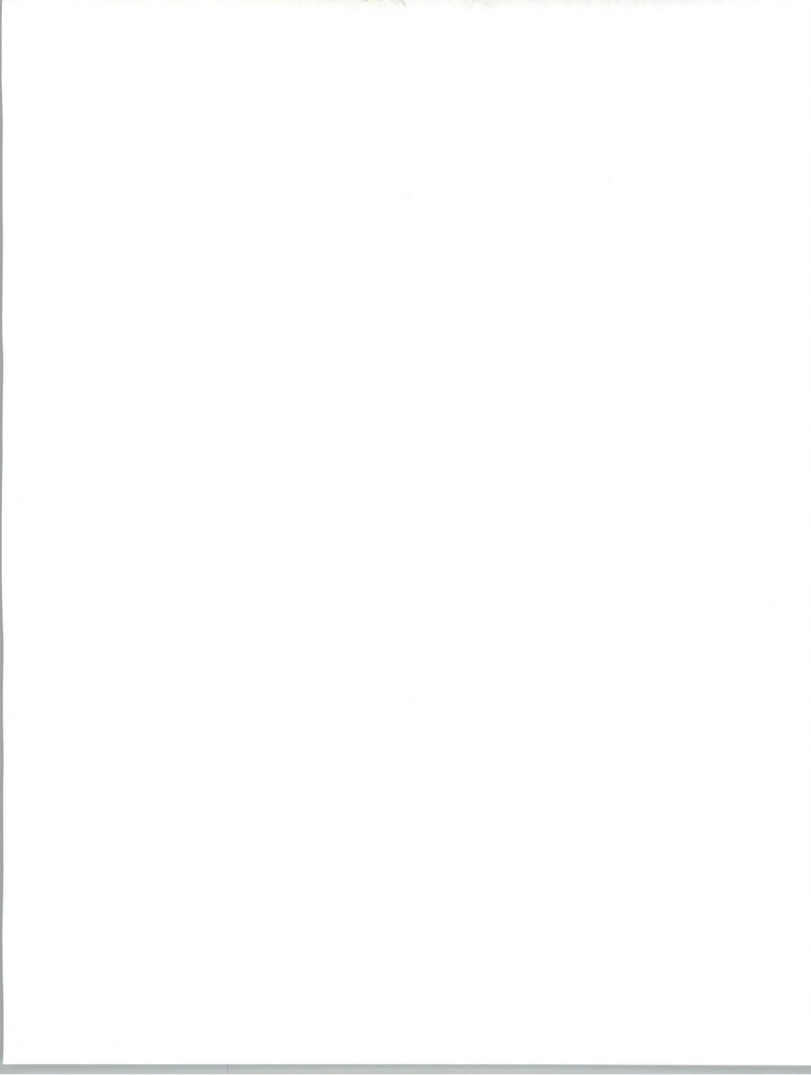

b. Processing Services

- Hospital bills are often paid by two or more insuring parties. A claims transaction may be sent out simultaneously or sequentially to the primary, secondary, tertiary, etc. payors. This unique billing problem must be incorporated into the transaction set and the overall interenterprise data flow design. It is equivalent to making a multiparty invoice.
- In general, health care transaction sets are extremely complex because there is so much possible data that insurance companies want to retain. Members of the X12 committee expect it will be a long time before data formats are ready for commercial use.

c. Real-Time Systems

Real-time systems may be required for the pre-admission certification mentioned above.

As mentioned above, PCS Inc. provides real-time claims processing for pharmacies.

d. Data Bases

A possible use of a central data base service in health care insurance would be the listing of specialist doctors allowed for referrals on a patient's insurance plan.

e. Case Study

- Memorial Sloan Kettering Hospital (\$370 million per year in revenue) submits approximately 90-92% of its insurance claims electronically. Claims adhere primarily to the UB82 format, although modifications are made to this format for every claims processor. The hospital submits claims to Medicare, Medicaid (both administered by HCFA), Blue Cross of New York, NEIC, and Blue Cross of New Jersey. Claims are submitted over telecommunication lines and via courier-delivered magnetic tapes. Sloan does not use a value-added network; all telecommunicated claims are sent directly to processor agencies. Sloan has no plans for receiving payments for the claims electronically.

Leading third-party processing service providers to the health insurance industry are NEIC (BT Tymnet), PCS, Inc. (Phoenix, AZ), and StellerNet, Inc. (San Francisco, CA). Also, many health care institutions use direct connections and magnetic tape transmissions with insurance payors.

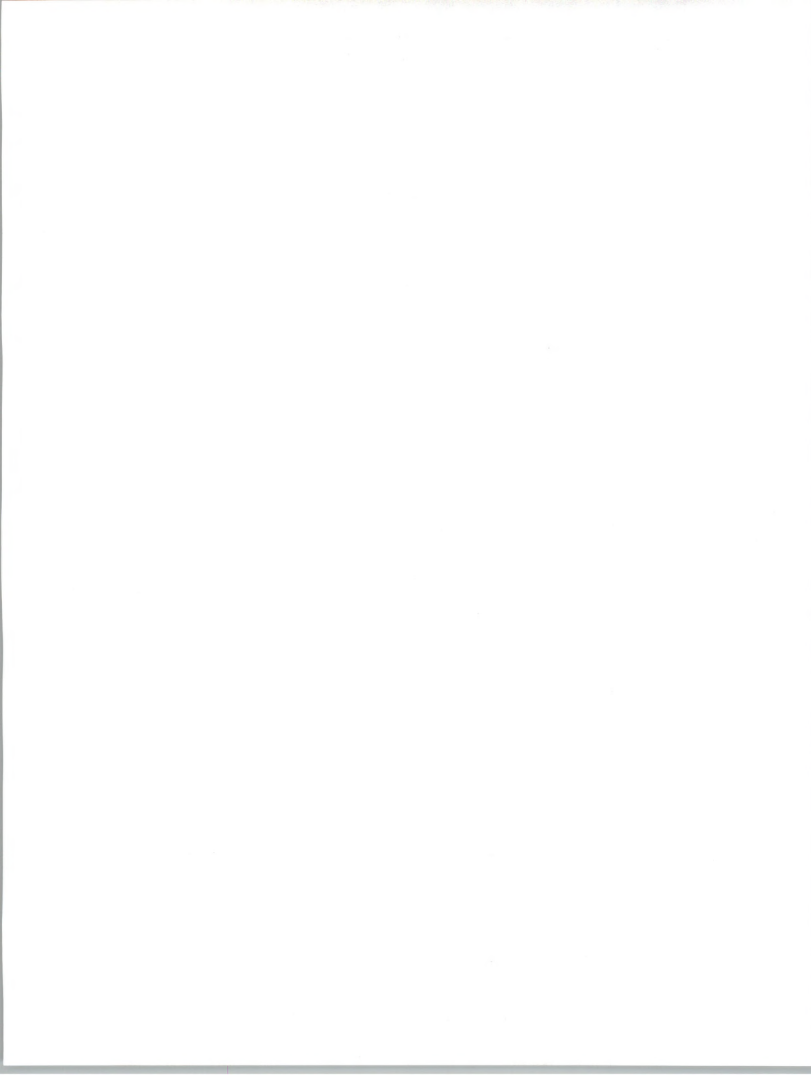

2. Pharmaceutical Supplies

The pharmaceutical industry was one of the pioneer implementors of EDI, starting with a proprietary format in the 1970s developed by and known as Ordernet. The Ordernet system allows wholesalers and buying groups to send purchase orders to drug manufacturers and to settle price discounts when manufacturers sell directly to hospitals. Ordernet still has a virtual monopoly in the pharmaceutical industry.

Exhibit VII-35 illustrates EDI use in the pharmaceutical industry.

EXHIBIT VII-35

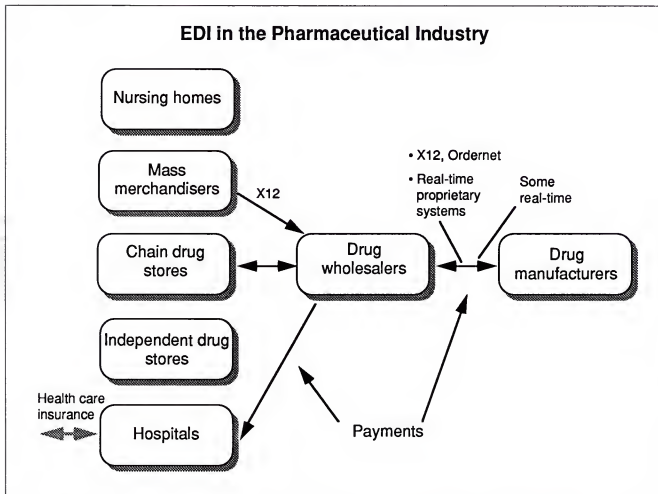

Approximately 75-80% of prescription drug orders from wholesalers are done by EDI.

Approximately 150 to 190 pharmaceutical manufacturers and approximately 80 to 120 wholesalers use EDI, according to the National Wholesale Druggists Association and Sterling Software/Ordernet.



The National Wholesale Druggists Association (NWDA) has been working with other health care associations, wholesalers and manufacturers to develop EDI transaction sets to cover electronic payments, contract awards, and charge-backs (related to price discounting), and to merge all formats into ANSI X12.

a. Data Base Services

Originally to assist drug makers and wholesalers in working out charge-backs, Ordernet developed the Medimetric data base and, in the process, introduced the EDI "transaction" data base.

Wholesalers agree to let Ordernet aggregate sales information taken from EDI transactions as well as data submitted by other means.

The resulting data base reveals sales of specific drugs by region and by wholesaler. The information is used for market research purposes as well as the settling of charge-backs. Often a drug maker negotiates a drug sale directly with a hospital, but instructs a wholesaler to deliver the physical product and collect payment. The wholesaler may have purchased the product from the maker at a cost greater than the price the maker negotiated. In this instance, the wholesaler is entitled to a charge back and submits an electronic charge-back form.

b. Real-Time Systems

As mentioned in the medical/surgical section below, captive systems for ordering pharmaceutical, medical, and surgical supplies are in operation. These systems require ordering terminals in hospitals that communicate directly with on-line order entry data bases operated by a large vendor.

c. Electronic Payments

Some large pharmaceutical manufacturers have required wholesalers to pay them electronically. The ANSI X12 820 transaction set is being used for this purpose.

Exhibit VII-36 lists leading users of EDI or EDI-like systems among pharmaceutical manufacturers and distributors.

3. Medical and Surgical Supplies

The electronic ordering of medical and surgical supplies has become dominated by proprietary systems of single manufacturers. These proprietary systems, however, list products of other vendors and support multivendor purchasing.

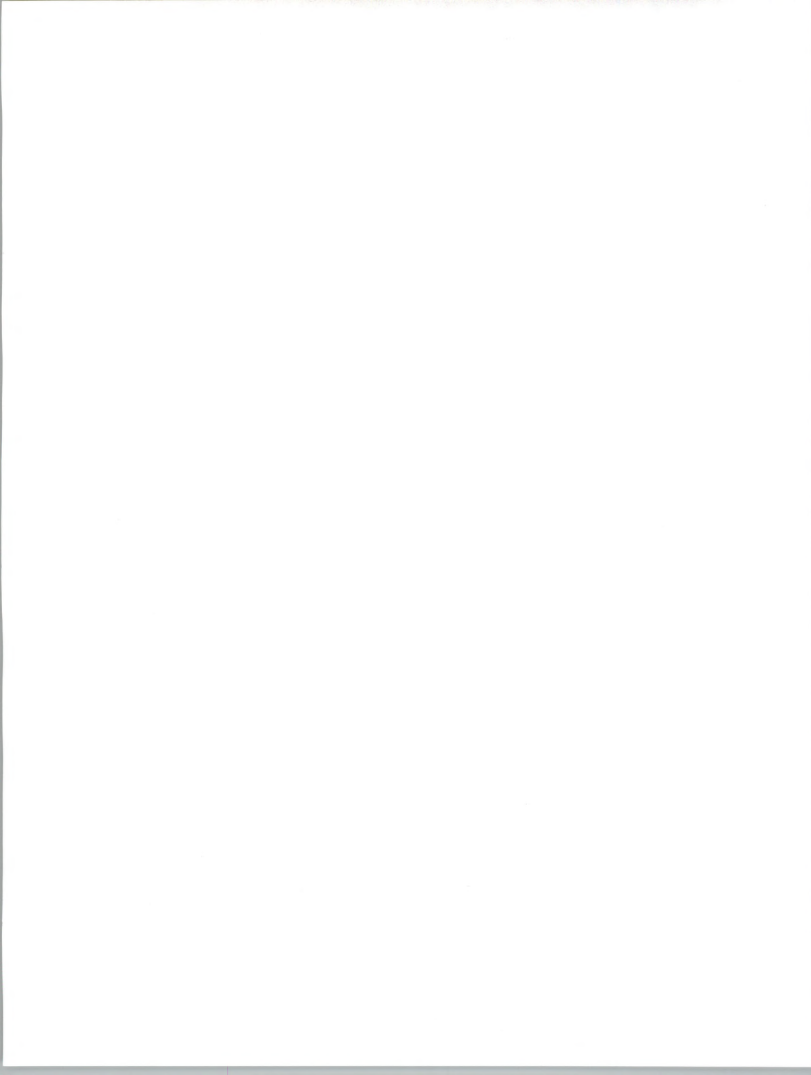

EXHIBIT VII-36

**Leading Users of EDI in Pharmaceutical
Manufacturing and Distribution**

- Abbott Laboratories
- Bausch & Lomb Pharmaceuticals
- Baxter Healthcare
- Bergen-Brunswig
- Bristol Meyers
- Ciba Geigy
- Du Pont
- Eli Lilly
- Hoffman-LaRoche
- Johnson & Johnson
- Upjohn

The classic system is Baxter-Travenol's ASAP (Analytical Systems Automated Purchasing), which was originally developed by American Hospital Supply in the 1970s.

Other systems today include:

- Johnson & Johnson's Cooperative Action (COACT) Plus
- Abbott Laboratories' QuikLink (with 3M Corporation, Standard Register, and several distributors)
- Other suppliers are reportedly developing their own systems, including American Healthcare Systems, AmeriNet, and Adventist Health Systems. Hospital group SunHealth Corporation (Charlotte, NC) uses CompuServe's network for its Buyline hospital purchasing system, which links SunHealth to medical and office supply companies.

With the proliferation of proprietary but multivendor systems, suppliers of medical and surgical equipment are listed on multiple systems. A single industrywide order clearinghouse has been suggested but not pursued.



In addition to these systems, according to the Health Industry Business Communications Council, approximately 100 medical/surgical supply makers conduct EDI with wholesalers and hospital buying groups. Many of these manufacturers provide pharmaceutical supplies and are counted in that industry classification.

Exhibit VII-37 profiles EDI use by the medical/surgical supply chain.

EXHIBIT VII-37**EDI in the Medical/Surgical Supply Chain****Leading users**

- **Manufacturers**
 - Abbott Laboratories
 - American Hospital Supply
 - Baxter Healthcare
 - Du Pont
 - GE
 - Humana
 - G.D. Searle
 - Johnson & Johnson
 - Kendall
 - Kimberly-Clark
- **Wholesalers**
 - Bergen-Brunswig
 - Meyers

S**Service Industries**

Today, business analysts and economists are redefining businesses according to a service paradigm. From the new perspective, most companies—product manufacturers and service providers alike—are largely service operations.



According to a recent *Harvard Business Review*, 76% of all U.S. workers are employed in industries commonly thought of as services: communications, transportation, health care, wholesale and retail distribution, financial services, and professional firms.

Of those workers in manufacturing industries, 65% to 75% perform service tasks ranging from critical production-related activities like research, logistics, maintenance, and product and process design to indirect staff services like accounting, law, financing, and personnel management.

Overall, services account for over three-fourths of all costs in most U.S. industries.

The service paradigm may just be an accounting/semantic trick—all economies are essentially people serving people to achieve some objective. Today's enthusiasm about the service interpretation may be a pragmatic method for orienting and motivating business.

INPUT will not adhere to a classification as radical as these experts propose; however, a service approach to classifying business activity is useful for users and vendors of EDI.

As with all varieties of information technology, EDI impacts areas of business activity that are service-oriented—namely, the processing of data arising from commercial transactions.

Companies whose business is primarily service will be impacted by EDI. As some economists speculate, information technologies (including EDI) will change manufacturing companies into service companies, and service companies into information companies.

The competitive playing field promises to be dramatically altered as service industries become increasingly automated. Some service businesses will innovate new services and thereby enter new markets (such as AT&T offering credit card services).

Other traditional service companies will lose out to information vendor companies or companies otherwise positioned well to sell information services—for example, Sterling Software/Ordernet's MarketQuest data base for pharmaceutical wholesalers entering the information publishing market of longstanding IMS.

Many service firms today exist merely as clearinghouses or otherwise processors of data for other companies.

- Subscription service companies process subscription orders for magazine publishers.

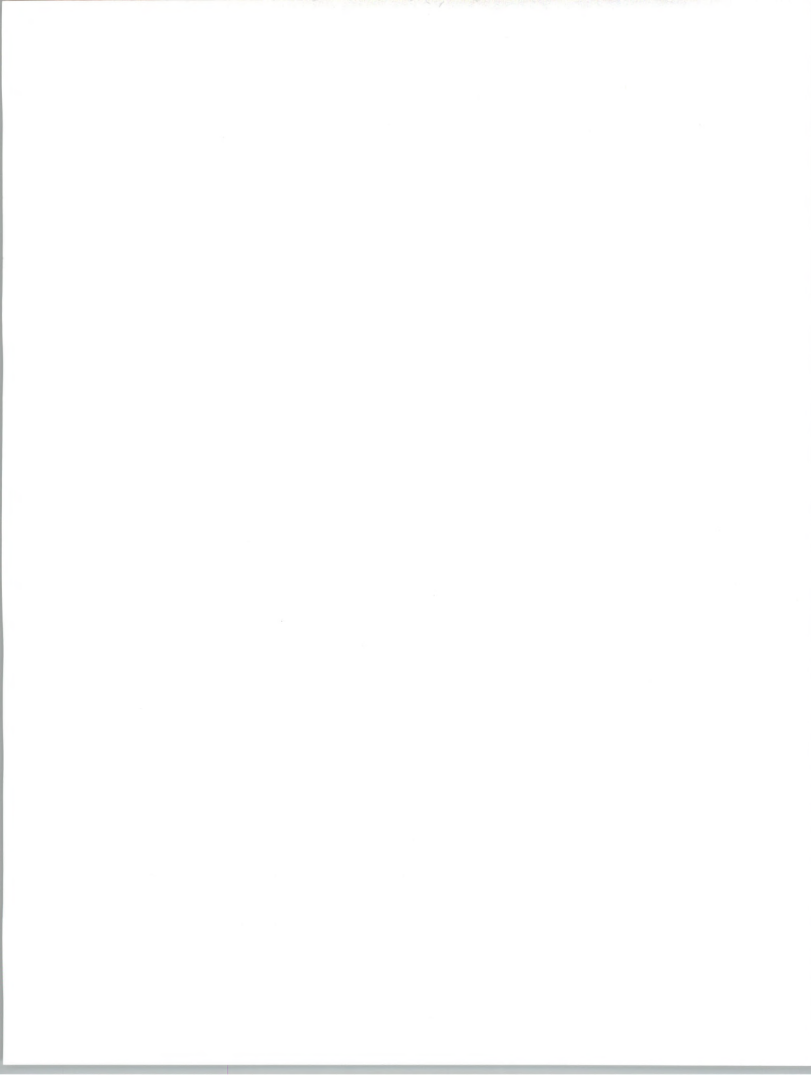

- Service providers in the advertising industry process invoices for broadcast media sellers, sending the invoices (with remittance detail provided by the media companies) to advertising agencies.
- In the film industry, third parties gather movie theatre attendance data and compile it for movie distributors.

These kinds of service companies may be the ones most affected by EDI, either because they adopt EDI and change their operations and procedures or because new competitors enabled by EDI technology will enter their traditional marketplace.

Exhibit VII-38 lists a variety of service industries in which EDI is taking place.

EXHIBIT VII-38

Service Industries Adopting EDI

- Equipment leasing (see Financial Services section)
- Temporary help agencies
- Travel and tourism
- Florists
- Video rental stores
- Subscription agencies
- Sanitation and trash disposal
- Commercial data base services (see Communications)
- Advertising (see Communications)
- Film distribution (see Communications)

1. Temporary Help Agencies

Temporary services are a very paper- and data-intensive business. The agency operates between the client employer and the temporary employee. In one major agency, every placement requires the following documents:

- A client master data sheet (detailing the client's business, address, statistics, etc.)



- A worker master data sheet (home address, tax status, dependents, etc.)
- A job order (stating that the client has agreed to pay X amount per hour for services and that the worker has agreed to accept Y amount per hour for work; X is hopefully greater than Y).
- A time sheet (whose weekly completion and submission to the agency is the responsibility of the temporary worker)
- An invoice (from the agency to the client corporation)
- Monthly reports to large client corporations (detailing all the temporary workers that the agency has provided for them, charges, and references to invoices that the agency has supplied to the corporation)

The largest temporary service agencies in the U.S. have hundreds of field offices throughout the country. The field offices are responsible for making work assignments, collecting worker and client data, and distributing checks. Headquarters offices are responsible for running payroll and invoicing. Data has to be transmitted between the field offices and headquarters.

Some of the largest temp agencies are experimenting with billing corporate clients and receiving payment from them via EDI. Also, direct deposit of payroll to the temporary workers is under consideration. But only approximately 20% of temp workers (typically, the 65-and-over group) are prepared to receive payroll checks electronically. One company is experimenting with sending monthly reports to corporate clients via EDI.

The temporary agency has cash flow challenges; typically, the agency pays the temporary worker before it collects from the corporate client. This fundamental practice, plus the highly competitive business of temporary agencies (there are more than 200 independent agencies in the metropolitan Los Angeles area) makes for narrow margins. Effective information systems are key to profitability.

The largest temporary help agencies in the country are Manpower, Kelly and Adia.

2. Subscription Agencies

Faxon is a subscription clearinghouse that resells periodical subscriptions to libraries. The company works with 40,000 publishers, 30,000 libraries and resells 250,000 titles. It is using EDI to invoice library customers.

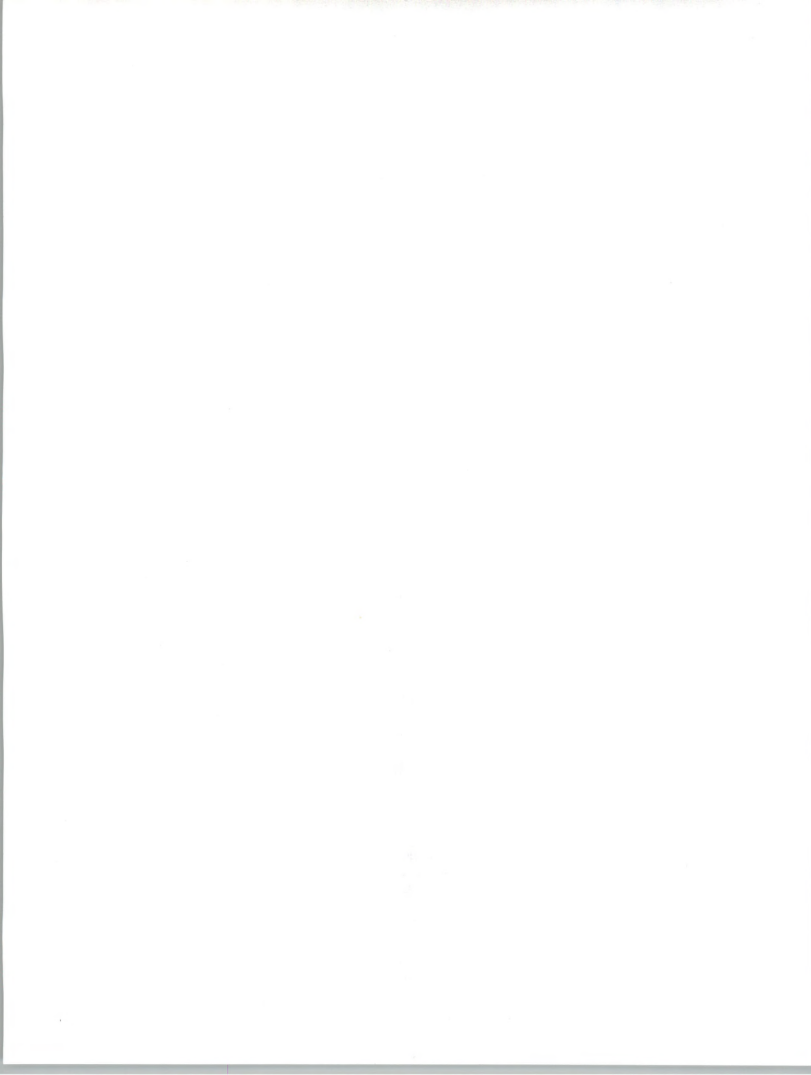

3. Video Rental Stores

Video distribution requires moving product from film distributors (Paramount, Orion, Columbia, etc.) to video stores. Video distributor ZBS Industries (Mayfield Village, OH), is pioneering the use of EDI formats to facilitate transactions among these parties.

4. Florists

Floral Transworld Delivery (FTD) of Southfield, MI, a nationwide chain of florists, has used a special facsimile service of BT Tymnet to receive orders, invoice customers, and to route floral delivery instructions among outlets. The company is considering adopting EDI.

5. Travel and Tourism

This industry consists of airlines, travel agencies, hotels and motels, car rental companies, cruise operators, train and motor coach companies, tour companies, museums, national parks, and computerized reservation operators.

The airline industry introduced reservation systems back in the 1970s, and, before that, it developed the EDI-based Specification 200 (now "2000") parts ordering system.

Now airlines from Asia, Europe, and North America are forming committees within the International Air Transport Association, UN/EDIFACT, ANSI X12, and national air transport associations to develop EDI transaction sets to aid in other areas of travel and tourism.

A combination of store-and-forward messages (traditional EDI) and real-time systems (such as computer reservation systems) is under development.

One area of effort is to link the data bases of airlines, hotels, and car rental companies. A combination of real time and store-and-forward could be used. Each business entity downloads its inventory status in batch to a central data base. Travel agencies interact with the central data base in real time.

6. EDI Transaction Sets that Characterize People

Service industry EDI (along with EDI applications in education, government, health care and finance) often calls for transaction sets that characterize people—the temporary worker data sheet, student transcripts, insurance policyholder data, loan applications, etc.



People transaction sets are a new frontier for EDI and, in particular, the X12 and EDIFACT standards bodies that will be responsible for developing them. Transaction sets to date have characterized things and their movement, not people.

People transaction sets bring up the issue of privacy: how easily do we want personal information to be movable among computer systems?

People transaction sets also have the unique difficulty of adequately capturing personal names. Names are difficult because they can change over time and are often abbreviated.

The Data Interchange Standards Association (the secretariat for X12 standards) is considering forming a subcommittee that develops people data formats.

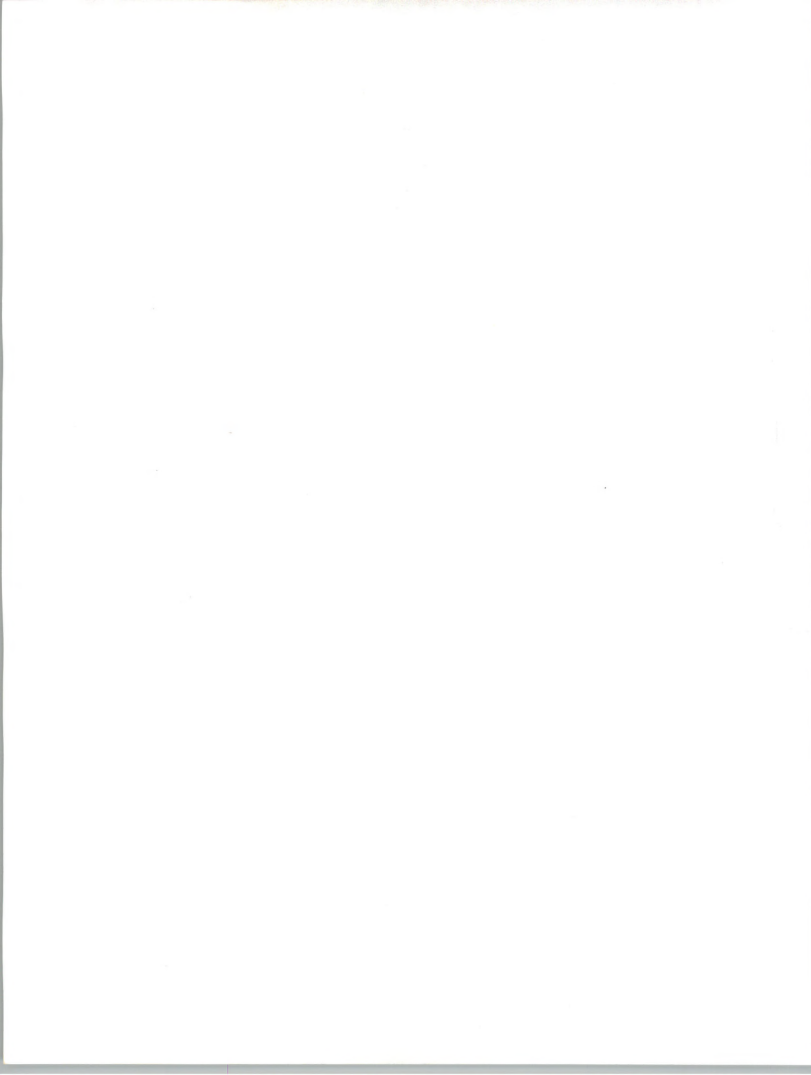



Conclusions and Recommendations

Vertical line separator

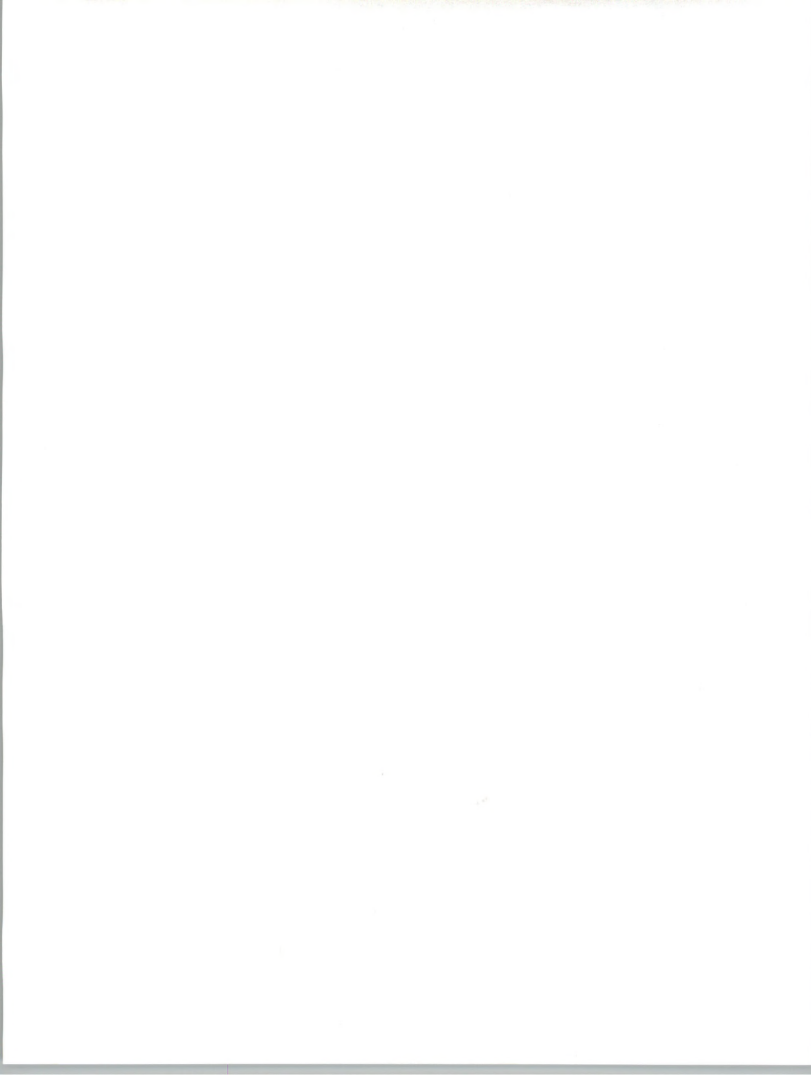



Conclusions and Recommendations

A

Conclusions

While the overall proportion of commercial transactions facilitated by EDI grows slowly, EDI is being implemented in more and more diverse industries (such as education, construction, film distribution, etc.). The general development of the EDI application by U.S. business can be summarized by the following conclusions:

- EDI will not be pervasive or ubiquitous. Other communication media will exist side by side with EDI such as telephone, facsimile, face-to-face deal-making, interactive (reservation systems), E-mail, and paper. EDI will be implemented selectively by companies when circumstances warrant it—namely, where transaction volumes for commodity, repetitively-ordered products are high.
- The potential for simple EDI translation software is limited. Software vendors need to look beyond simple translation and develop applications.
- The potential for network services is limited in that critical, value-adding functionality is being done on customer-premise software.
- Professional services, in particular systems integration companies, have the greatest potential for growth and involvement in the EDI adoption process.
- Markets for commercial transaction data (consumer and business point-of-sale data, EDI transactions, etc.) are emerging. Electronic technologies make this data easily obtainable, transferable, and therefore, marketable. Citicorp, IMS, Sterling, and Dun & Bradstreet are leaders in this area with regard to EDI.

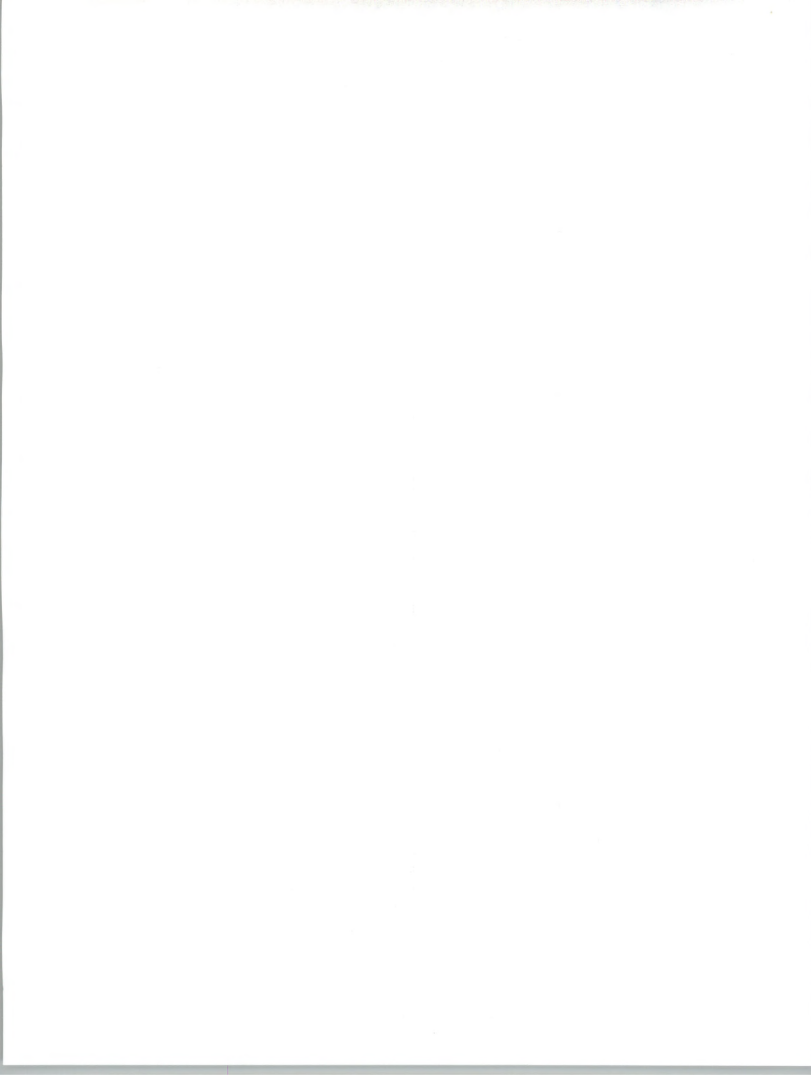

- As margins are squeezed in the traditional business of production and distribution, the information service provided to customers becomes a differentiating factor.
- EDI has huge potential in financial services, where clerical effort and paperwork are high.
- EDI has fundamental economics that are not yet understood. It reorganizes businesses, industries, and economies. It redefines organizational entities within the macroeconomic system: buyers and sellers become more integrated; industries become integrated as a result of collectively defining standards; vendors are often users; users are often vendors; competitors form consortia (such as in the case of transaction data bases); within a single company departmental boundaries and job descriptions are redefined (because properly implemented EDI touches all functional groups of a company—sales, manufacturing, accounting, shipping—and buyers, product designers, production line workers, sales personnel, and accounting workers become a single team).
- There may be a “macro” 80-20 rule governing the adoption of EDI, which sets the upper limits of its adoption in the economy. Eighty percent of the U.S. GNP is produced and distributed by 20% of its companies. (As mentioned earlier, the distribution is probably more extreme. Of the \$5.1 trillion GNP of 1989, the Forbes 500 accounted for \$3.2 trillion (62%) and the Fortune 500 accounted for \$2.1 trillion (41%).) When the key 20% of the economy’s companies get up and running with EDI, there may be little value to the economy in bringing on other companies.

B

Recommendations for Specific EDI Constituencies

1. Users

- Consider EDI part of a larger business strategy. Position EDI to support closer relationships with trading partners and to support better information systems for management. Also, consider how you can work with other companies in your supply chain to improve the chain’s overall coordination. Talk with network vendors about what they can offer.
- Shop around—there are plenty of suppliers of EDI products and services. It is a buyers’ market. Rely on network providers and software vendors for implementation plans and training.
- Build EDI capabilities with key trading partners. Establish EDI linkages with customers as they request it. Establish EDI linkages with suppliers where you will realize the greatest reduction in transaction costs. Use other communication media for other trading partners and transactions. Don’t attempt to completely convert every trading partner to EDI.

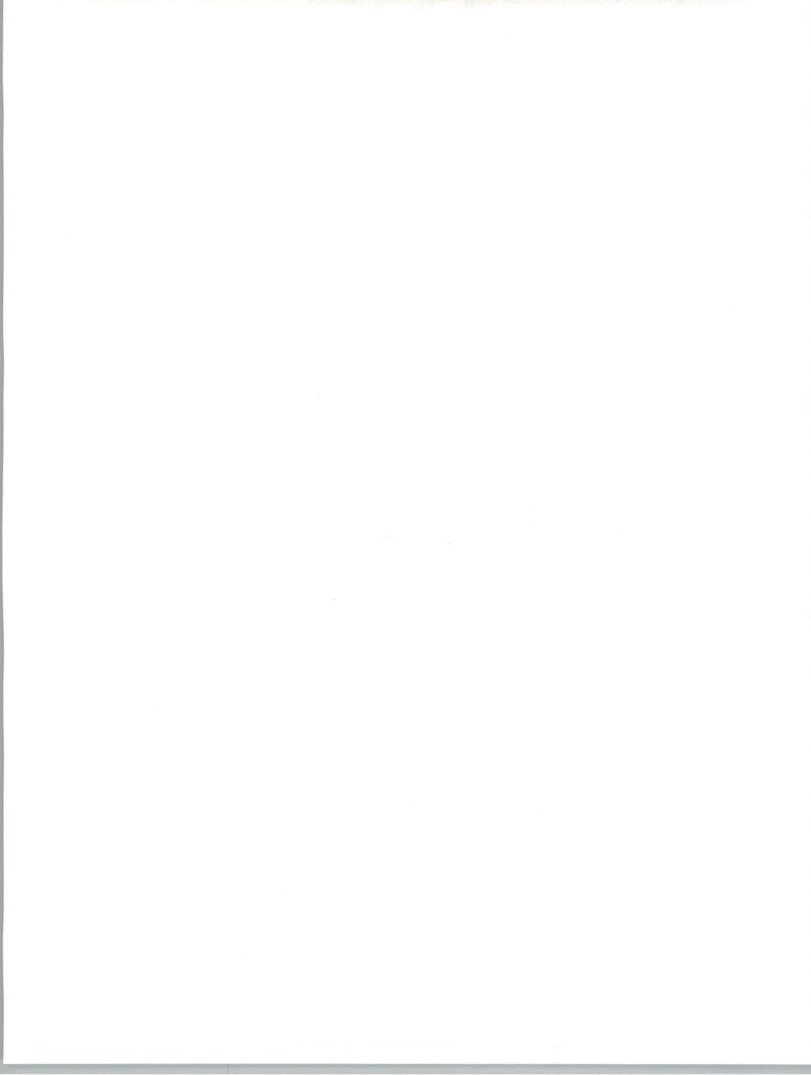

- Prepare for organizational evolution. Develop a strong awareness of and willingness among employees to keep customers satisfied. Build information systems (computer and paper-based) that support good management control procedures for insuring customer satisfaction. Stress teamwork and employee participation. Develop/revamp accounting systems and methods so as to capture relevant management data as quickly as possible.
- Get involved in X12 and EDIFACT standards organizations, and/or your industry trade group responsible for setting EDI guidelines.
- Get involved in or help establish an EDI users' forum in your locale (modeled on those formed in Atlanta and Chicago).

2. Network Providers

- Target specific industry sectors (retail, electronics, utilities, etc.) and offer turnkey solutions to customers (i.e., help a hub bring up all trading partners in a single project).
- Establish an implementation program to help large accounts bring up EDI trading partners.
- Offer software, systems integration, education and training to EDI customers.
- Sell EDI in a "hub-and-spoke" approach; sell to a large company and its many trading partners simultaneously.
- Develop advanced services, particularly data base services and services of providing information on transactions.
- Offer business brokering services. Make these services an expansion of your trading partner implementation programs.
- Run networks like a utility—take an economic optimization approach (see below).
- Offer financial EDI services either through alliances with banks or through your own services.

3. Software Vendors

- Develop integration tools (such as mapping tools, application interfaces, and event-driven architectures).

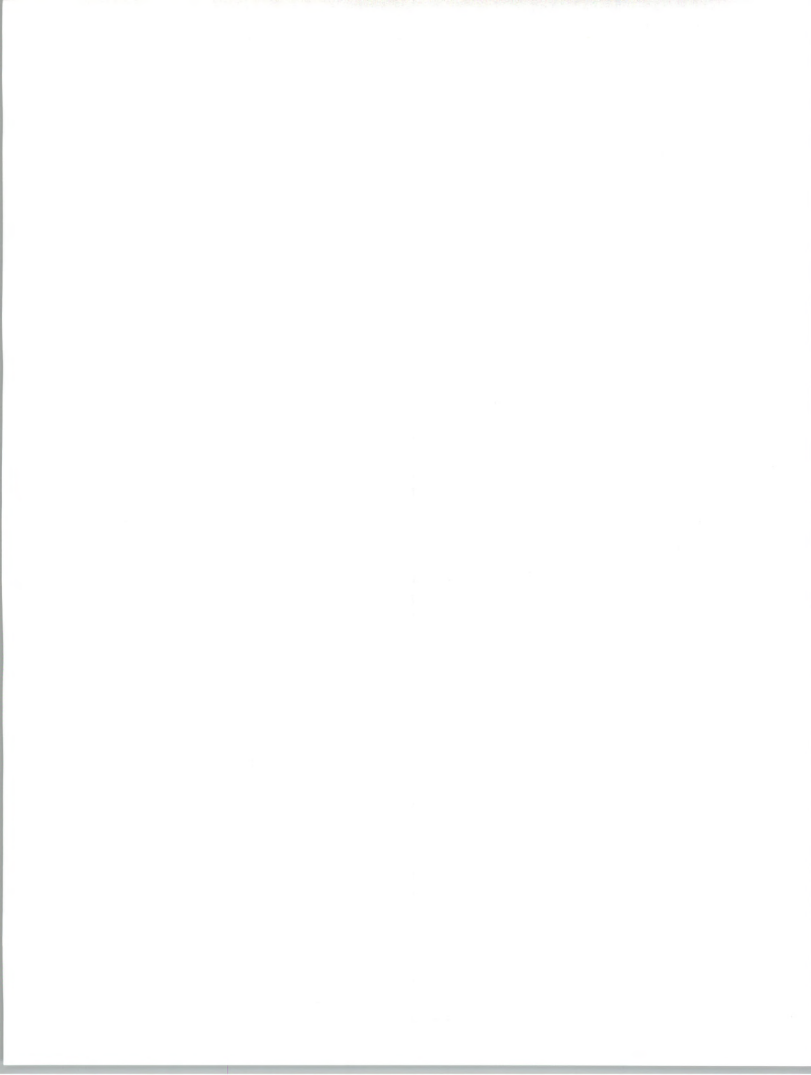

- Make technical and/or marketing alliances with application developers. Make it easy for users to link application software to your translation software.

4. Professional Services Providers

- Focus on integration services (and watch out for competition from network service companies).
- Offer systems maintenance and optimization services.
- Seek customers who are large hub companies that have many spoke companies.
- Target vertical industries.

Exhibit VIII-1 summarizes some of the key recommendations for vendors of EDI products and services.

EXHIBIT VIII-1

EDI Vendor Recommendations

Recommendations	Service Providers	Software Vendors	Professional Services Firms
Target vertical industries	✓		✓
Offer systems integration support	✓	✓	✓
Offer advanced services and new features	✓	✓	
Target hub companies	✓		✓
Seek alliances	✓	✓	✓

of the study, the researchers found that the majority of the women who were sexually abused by their partners were also physically abused. The researchers also found that the majority of the women who were physically abused by their partners were also sexually abused. The researchers concluded that the two types of abuse are often intertwined.

In another study, researchers found that women who were sexually abused by their partners were more likely to experience mental health problems, such as depression and anxiety, than women who were not sexually abused. The researchers also found that women who were physically abused by their partners were more likely to experience mental health problems than women who were not physically abused. The researchers concluded that both types of abuse can have a negative impact on mental health.

Overall, the research suggests that both physical and sexual abuse can have a significant impact on women's mental health. It is important for researchers and clinicians to continue to explore the complex relationship between these two types of abuse and their effects on women's well-being.

3.1.2. Impact of Physical Abuse on Women's Mental Health

Physical abuse is a form of violence that involves the use of force or coercion to cause harm or injury to another person. It can take many forms, including hitting, slapping, kicking, and choking. Physical abuse is often used to control and dominate another person.

Research has shown that physical abuse can have a significant impact on women's mental health. Women who are physically abused are more likely to experience depression, anxiety, and post-traumatic stress disorder (PTSD). They are also more likely to have low self-esteem and feel isolated.

The researchers also found that women who were physically abused by their partners were more likely to experience mental health problems than women who were not physically abused. The researchers concluded that physical abuse can have a negative impact on mental health.

3.1.3. Impact of Sexual Abuse on Women's Mental Health

Sexual abuse is a form of violence that involves the use of force or coercion to engage in sexual activity with another person. It can take many forms, including rape, sexual assault, and sexual harassment. Sexual abuse is often used to control and dominate another person.

Research has shown that sexual abuse can have a significant impact on women's mental health. Women who are sexually abused are more likely to experience depression, anxiety, and PTSD. They are also more likely to have low self-esteem and feel isolated.

The researchers also found that women who were sexually abused by their partners were more likely to experience mental health problems than women who were not sexually abused. The researchers concluded that sexual abuse can have a negative impact on mental health.

3.2. Impact of Abuse on Women's Physical Health

Abuse can have a significant impact on women's physical health. Women who are physically abused are more likely to experience injuries, such as bruises, cuts, and fractures. They are also more likely to experience chronic pain and other physical health problems.

Research has shown that women who are physically abused are more likely to experience physical health problems than women who are not physically abused. The researchers concluded that physical abuse can have a negative impact on physical health.

Overall, the research suggests that both physical and sexual abuse can have a significant impact on women's physical health. It is important for researchers and clinicians to continue to explore the complex relationship between these two types of abuse and their effects on women's well-being.

C

Future Directions of EDI

1. Whole value chains, not just individual production processes or companies, will be subject to mathematical optimization and/or cybernetic self-regulation.

The reduction of the number of suppliers to a company and the subsequent sharing of proprietary data with those few remaining is leading to a reorganization of industry and a redefinition of competition. Fully IS-integrated companies that are, in addition, electronically networked with other fully IS-integrated companies make for whole value chains that are subject to mathematical optimization. The supply chain that links textile mill Milliken with apparel manufacturer Levi Strauss with retailer Mervyn's is on its way to such optimization. Point-of-sale data generated by final consumers is the ultimate "demand-side" driving data; inventory-status data generated by upstream suppliers is the ultimate "supply side" driving data.

Networks and EDI hub companies appear to be the most likely candidates to perform the optimizing. However, professional service companies and software developers may be the ultimate players because the optimization is ultimately a function of each processing point in the value chain. Software at each point will have to be built that can adapt to the status of the overall chain, the status being fed to each point electronically.

2. Business planning and design will take on a new dimension as a result of digitally integrated companies and value chains.

It is ironic that at the same time the communist economies discard central planning, capitalist economies adopt it in the form of whole industries gathering to standardize how they signal each other to enact exchanges, companies reducing the number of suppliers to induce long-term, mutually beneficial relationships, whole supply chains sharing proprietary data (namely, sales and inventory data), and the integration of supply chains that traverse the entire globe.

This convergence—planned economies becoming more market-driven, market economies becoming more collectively planned—can be interpreted as the movement of the world into a non-polar, non-ideological economic environment. Communication/information systems are playing a central role. Greater communication brings about greater coordination of resources and an ability for managers to be concerned about a greater number of factors (for example, not just price/cost but quality, manufacturing design, timeliness of production or delivery to customers, etc.).



Design becomes the operative activity for developing competitive edge. Design to reduce costs. Design to differentiate products. The division of labor is shifting away from military-style management/worker roles to designer roles: software designers, business designers, product designers, manufacturing designers.

3. EDI is spearheading the evolution from business management to economic management of the economy's production/distribution apparatus. Management by ad hoc business techniques will be superseded by economic management.

EDI involves the explicit hard coding of business processes and conditions into electromechanical systems. Event-driven EDI architectures, data mapping tables for individual trading partners, data bases of trading partner profiles, the seamless movement of data from application to application within and among companies, whole trading communities collectively designing machine-processable coordination messages (standardized EDI messages)—these and similar instances represent a second level of business management. Rather than being concerned with managing the immediate fulfillment of a business promise to the customer (first-level management), the second level is concerned about designing systems that can recurrently fulfill those promises. Embedding digital systems with business terms and conditions (translation software data mappings, trading partner profiles), process-to-process transaction coordination messages (EDI standards), and processing methods (event-driven architectures, numerical control, CAD/CAM systems) permits managers to oversee business from a standpoint of economic analysis rather than ad hoc business techniques.

4. Economic analysis will be more readily applicable to business as a result of EDI (and other data capture technologies).

With ever-increasing automation of business processes, we are achieving cybernetic control of these processes. Numerical control manufacturing machines, bar coding, CAD/CAM systems, commercial data bases, EDI, and other like technologies are making possible business decisions based on "perfect information" (an assumption of theoretical economics that was a stumbling block to applying economics to real-world business situations).

Already, various business pundits (namely, Michael Porter, Robert Kaplan and Peter Drucker) are calling for and are incorporating economics into business analysis.

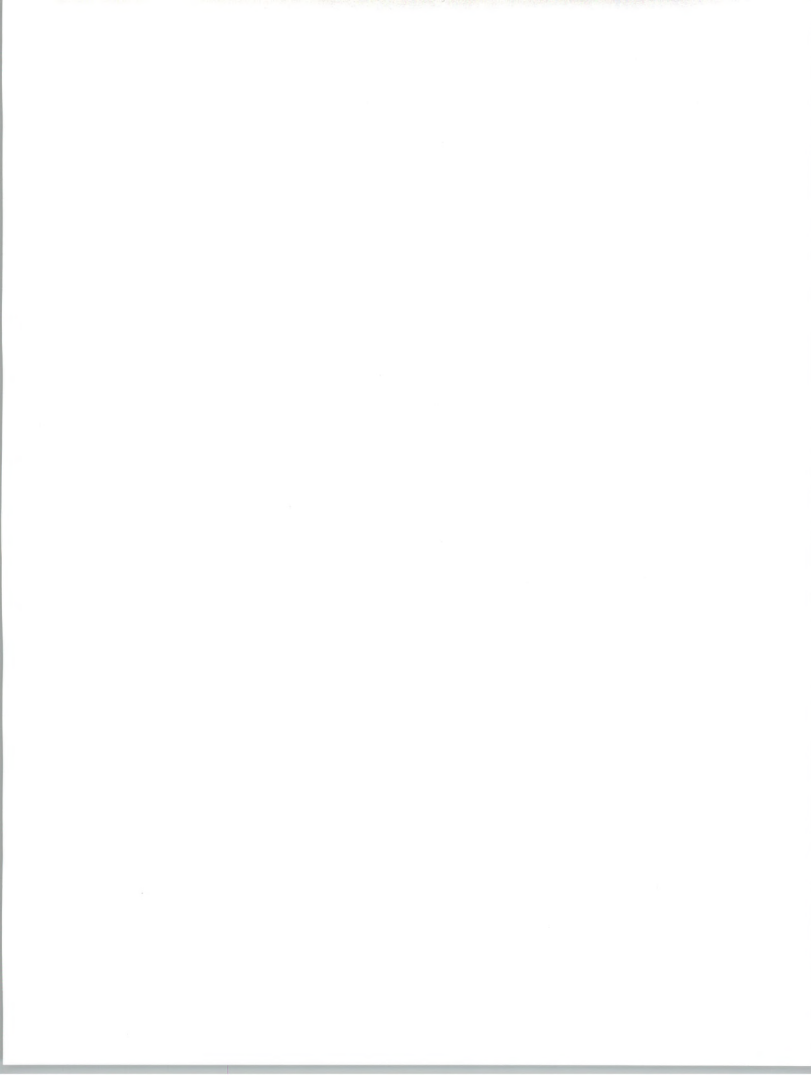

Theoretical work relevant to the ongoing systemizing of business is being done in the areas of information economics, opportunity cost analysis, transfer pricing, transaction cost analysis, management accounting practices, and the Austrian school of economics notion that entrepreneurial/market activity is fundamentally a learning activity.

These and the more practical issues of EDI standards development, the impact of EDI on accounting, and auxiliary information systems technologies to EDI (such as bar coding, image processing, CAD/CAM, etc.) are explored in INPUT's study, *EDI: Business Integration Issues*.





Appendixes

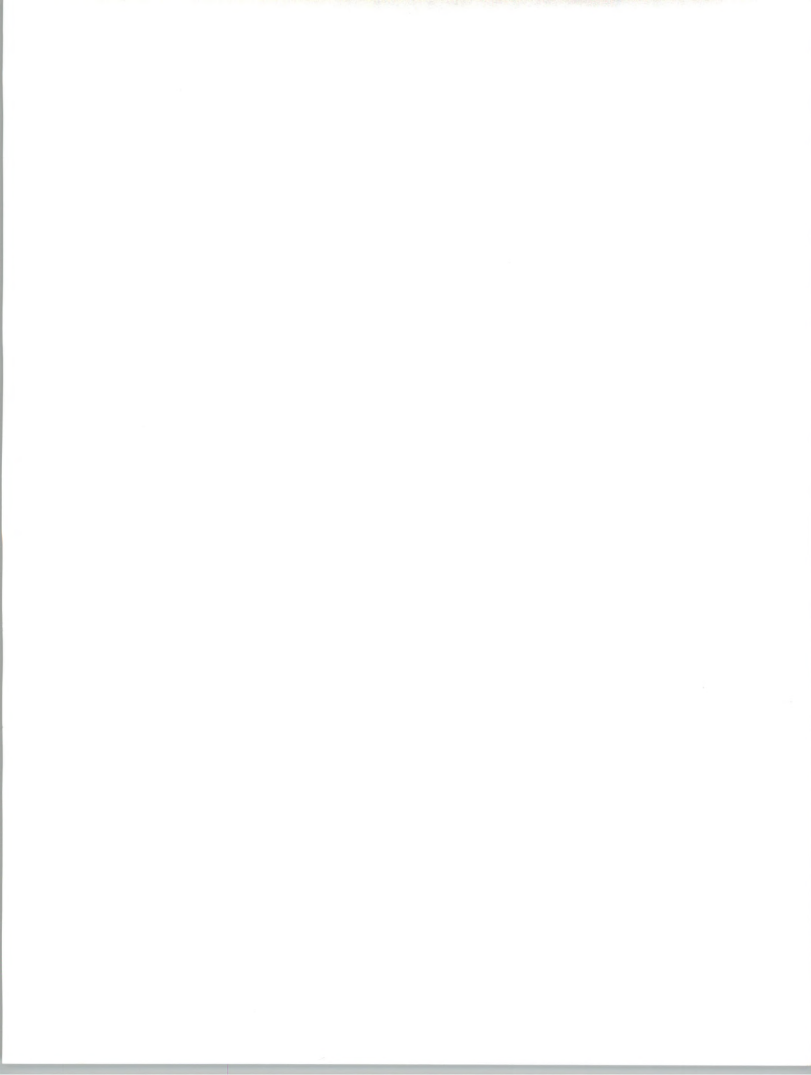



Definitions

For definitions of EDI terms, please see glossaries contained in other INPUT EDI reports such as *EDI: Business Integration Issues (1990)*, *EDI Interrends North America (1989)*, or *EDI Advanced Services (1989)*.

For further definition of delivery modes and INPUT's taxonomy of the information services market, please see Appendix A of INPUT's report, *Industry Sector/Cross-Industry Markets* (one of the reports of INPUT's Market Analysis Program).

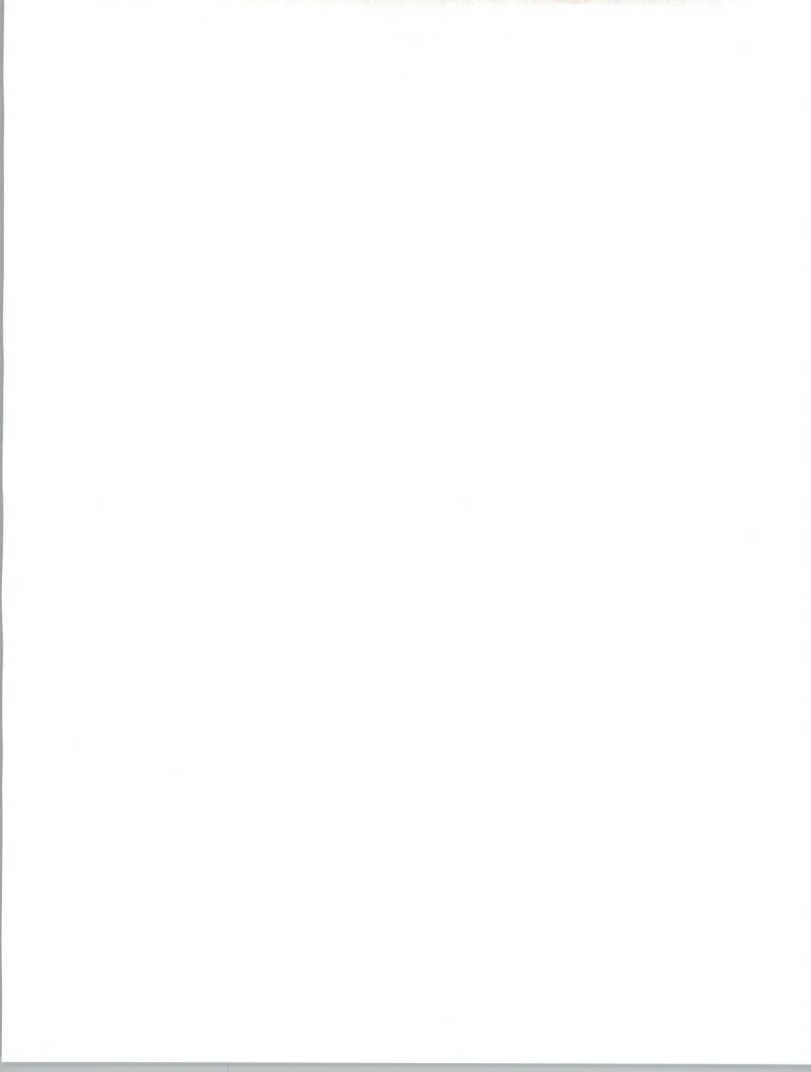

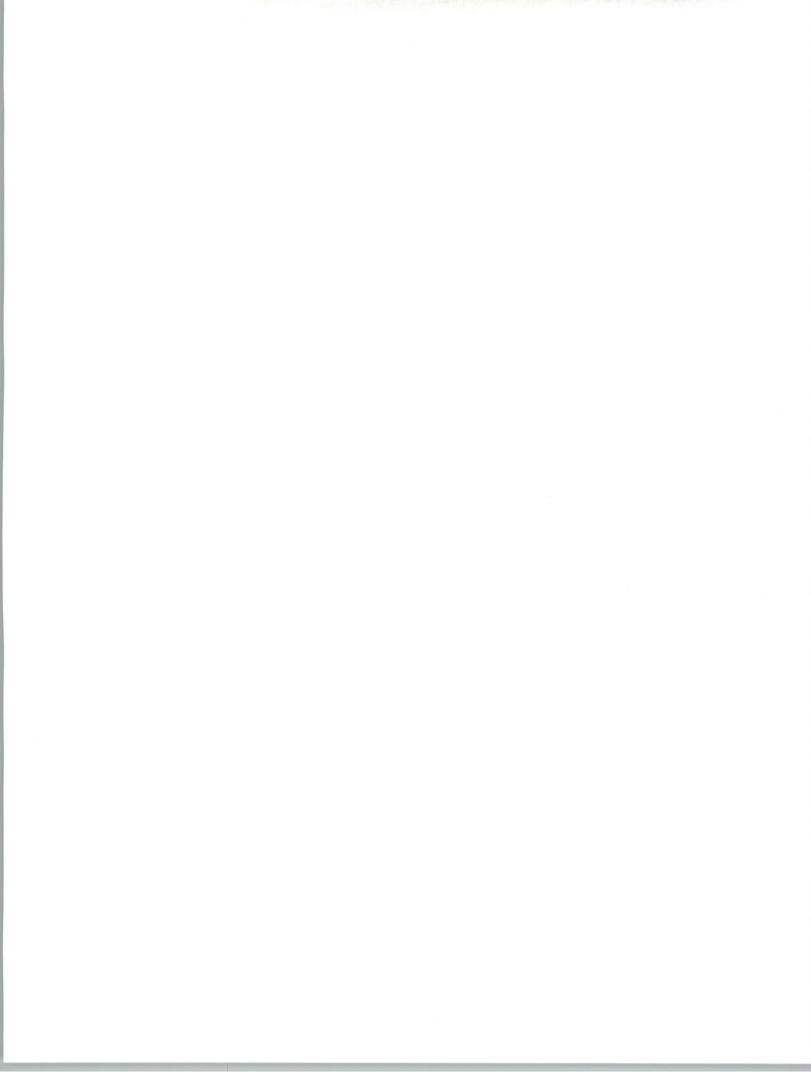

B

EDI Market Forecast by Delivery Mode, 1990-1995

EXHIBIT B-1

EDI Market Forecast by Delivery Mode, 1990-1995 (\$ Millions)

Delivery Mode	1989	Growth 89-90 (Percent)	1990	1991	1992	1993	1994	1995	CAGR 90-95 (Percent)
Total EDI Market	94	24	117	141	170	203	245	276	19
EDI Software	19	31	25	30	34	37	39	40	10
EDI Network Services	50	22	61	73	89	107	133	146	19
EDI Professional Services	25	24	31	38	47	59	73	90	24







Forecast Reconciliation

EXHIBIT C-1

Forecast Reconciliation

Delivery Mode	1989 Market		Variance from 1989 Report		1994 Market		Variance from 1989 Report		1989 Report	1990 Report
	1989 Report (Forecast) (\$M)	1990 Report (Forecast) (\$M)			1989 Report (Forecast) (\$M)	1990 Report (Forecast) (\$M)			89-94 CAGR (%)	89-94 CAGR (%)
	(\$M)	(\$M)	(\$M)	(%)	(\$M)	(\$M)	(\$M)	(%)	(%)	(%)
EDI	280	94	(186)	-66	1,400	276	(1,124)	-80	38	24

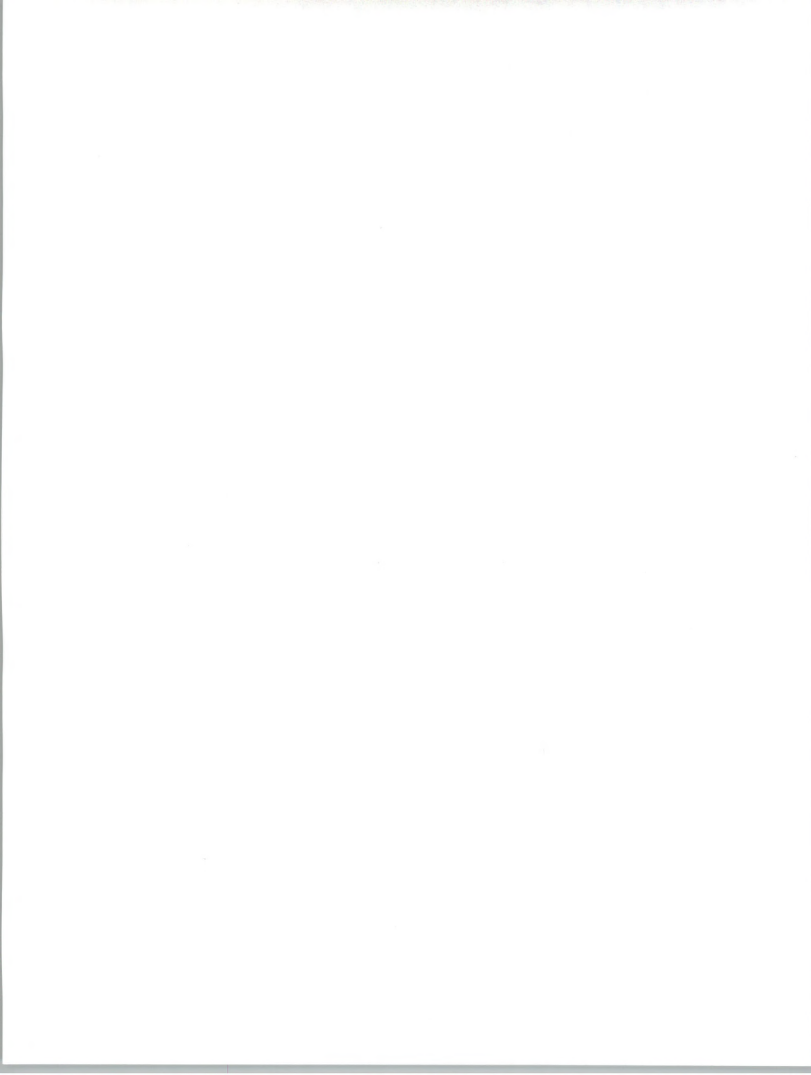

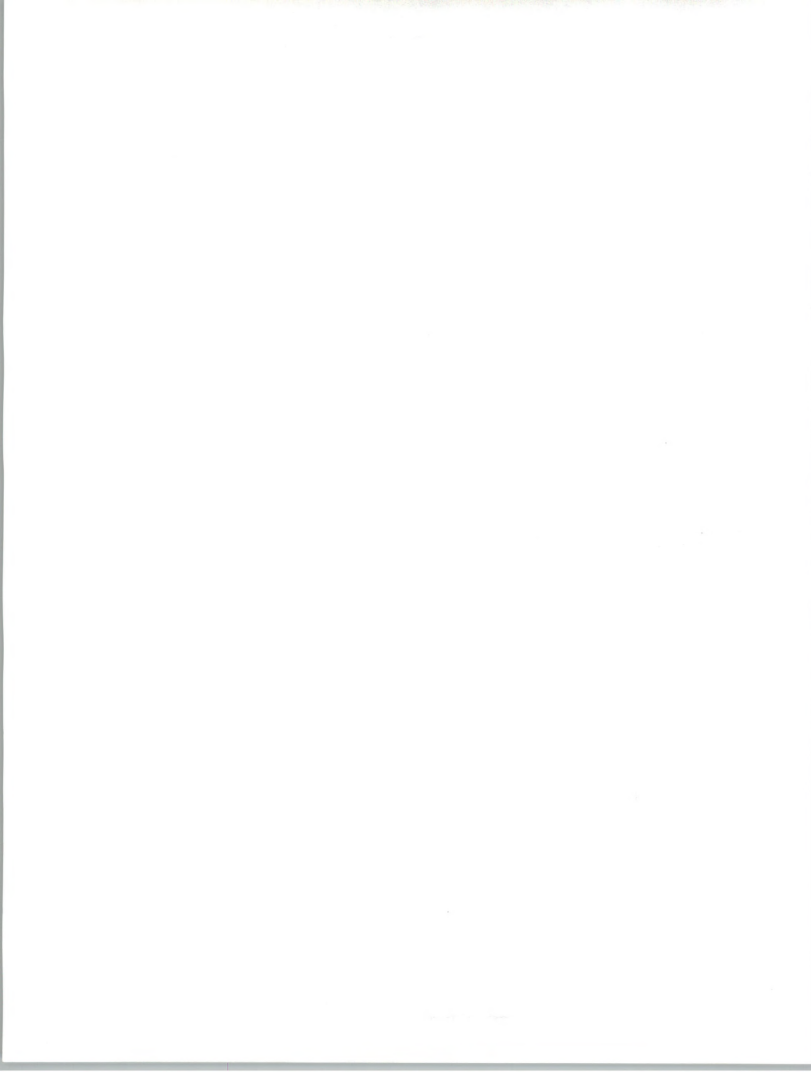



EDI User Questionnaire

For the moment, let's use the broadest definition of EDI to be inclusive of all the possible implementations of EDI that you may have.

Let's define it as: the exchange of electronic data in standard and nonstandard formats between two computer software applications. The transmission medium can be a value-added network, a floppy disk, dial-up telephone lines, magnetic tapes, or possibly punched cards. Formats can be X12, WINS, TDCC, EDIFACT, UCS, or proprietary formats determined by you and your trading partners. Also, a format may include the particular file format of a particular application, such as a Lotus 1-2-3 or a CAD/CAM application.

(1) Given this definition of EDI, are you currently using EDI in your organization for the exchange of business data? [If no, thank them]

(2a) Do you use:

- only standard EDI (this includes X12, EDIFACT, TDCC, WINS, UCS, Petrodex, UB82, and the various implementations of these defined by industry-specific implementation guidelines) [go to question 3]
 only proprietary EDI [go to question 3]
 both proprietary and standard EDI [go to question 2b]

(2b) If you use both proprietary and standard formats, please estimate the relative proportions of each in terms of total data traffic between you and trading partners.

___ percent is sent via standard ___ percent is sent via proprietary formats

(3) How many trading partners total do you now have?

using standard EDI ___ using proprietary formats ___

(4) How many trading partners total do you expect to have in the next 12 months?

using standard EDI ___ using proprietary formats ___

[interviewer: please calculate percentage growth of the combined standard and proprietary trading partners. _____]



(5) In what application area(s) does your company use EDI? Please indicate for each area whether your EDI system uses proprietary or standard formats (Please indicate what standards family you use if you use a standard — e.g., X12, TDCC, etc).

Application	Standard	Proprietary
POs to suppliers	<input type="checkbox"/>	<input type="checkbox"/>
POs from customers	<input type="checkbox"/>	<input type="checkbox"/>
Invoices from suppliers	<input type="checkbox"/>	<input type="checkbox"/>
Invoices to customers	<input type="checkbox"/>	<input type="checkbox"/>
Transportation documentation (ship notices, etc.)	<input type="checkbox"/>	<input type="checkbox"/>
Payments (to or from trading partners)	<input type="checkbox"/>	<input type="checkbox"/>
Other	<input type="checkbox"/>	<input type="checkbox"/>
_____	<input type="checkbox"/>	<input type="checkbox"/>
_____	<input type="checkbox"/>	<input type="checkbox"/>

(6) For the documents that you transmit in EDI (e.g., purchase orders, invoices, etc.), approximately what percentage of these types of documents are transferred electronically? In other words, EDI documents represent what percent of those documents transmitted in both EDI and paper modes?

- 0%
 <5%
 5-24%
 25%-49%
 50%-74%
 75%-99%
 100%
 don't know

comments: _____

(7) For the EDI data that you either transmit or receive, please tell me how deeply integrated it is with your software applications that use/generate it. In other words, are EDI purchase orders, once they have been translated, fed directly into your order entry system? Does your accounting software send invoice data directly to your translation software so that EDI invoices are formatted and sent? etc.

- not integrated; the EDI software stands alone relative to other application software; all data must be rekeyed [go to question 8]
 partially integrated; some data is rekeyed and/or manually reformatted while other data is electronically delivered into application software [go to question 7b]
 thoroughly integrated; no rekeying is necessary [go to question 8]

comments: _____

(7b) If you are partially integrated, please estimate the percentage of data that is integrated versus the percentage that is not integrated. ____ percent is integrated



(8) To what industry classifications do your current and expected EDI trading partners belong? using standard EDI _____

using proprietary formats _____

(9) How is the data transported between you and your trading partners? (if multiple media is used for each data format, please estimate percentages)

	standard	proprietary
third-party network	_____	_____
direct dial-up telephone lines	_____	_____
magnetic tapes or floppy disks	_____	_____
other	_____	_____

(10) If you use proprietary formats, are you planning to convert the proprietary EDI that you are now conducting over to standard X12 (or EDIFACT) formats?

yes no

(11) Please indicate below how many trading partners in Europe, Asia and/or Latin America you are conducting EDI with and how many you plan to conduct EDI with in the next twelve months.

	number of active TPs	number of planned TPs in next 12 months	just a possibility
Europe	_____	_____	_____
Asia	_____	_____	_____
Latin America	_____	_____	_____

(12) Are you using EDI to pay or receive payments from trading partners?

yes no

If yes, with how many trading partners? _____

If no, will you in the next 12 months?

- yes
 no
 don't know

(13a) Do you communicate with any of your trading partners (EDI or non-EDI partners) using electronic mail? yes no don't know

(13b) If yes, to what industry classifications do(es) this/these trading partner(s) belong?

The remaining questions refer to just public standard EDI (which includes X12, EDIFACT, TDCC, and WINS formats).



(14) How closely do you follow the X12 or other public standards in practice?

- strictly adhere to generic standard
 use according to industry implementation guideline
 modify the format to accommodate individual trading partner(s)

(15) Do you or your trading partners fill in data fields with data that does not conform to standard (for example, place free text when the standard calls for a code number, etc.)?

- yes no

(16) Are there any modifications to today's EDI standards that you would like to see implemented? (Please explain)

III. Software Issues

(17) What type of computer is used to run your EDI software?

- mainframe: IBM MVS IBM VSE IBM VM
 Unisys Digital HP 3000
 Tandem Stratus
 Other (please specify _____)
- mini: IBM System 3X series IBM AS400
 Digital Other (please specify _____)
- micro: IBM (or compatible) MS-DOS
 IBM (or compatible) OS-2
 Apple Other (please specify _____)

(18) How was your EDI software obtained? (check one)

- purchased or leased from a vendor [proceed to question 18b]
 written in-house [skip to question 19]
 written in conjunction with outside consultants [skip to question 19]
 obtained from main trading partner [skip to question 19]
 other (please specify)

(18b) If purchased or leased, please provide the vendor and product names in the space provided below

vendor name _____
 product name _____

(18c) On a scale of A to F (A being excellent, F being inadequate), how would you grade this software?

A B C D F

(18d) Are you planning to replace this software?

- no yes, with what? _____

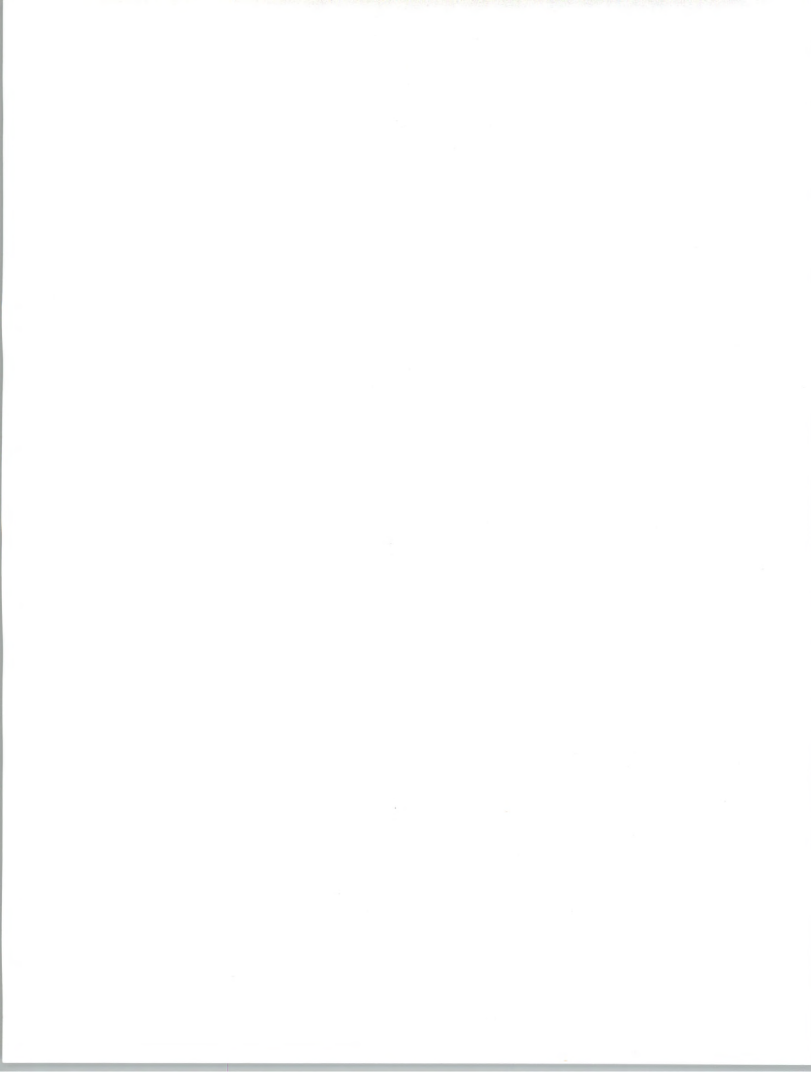

(19) Does your current EDI system scan and/or generate bar codes or is it in some way integrated with a bar code system?

- yes
 no

IV. Cost Issues

(20) Please estimate how much money you have spent for the following EDI products and services.

- initial investment
 in software _____
 in outside consulting/educational services _____
- ongoing costs
 in network charges (per year) _____
 software maintenance (per year) _____
 salaries of personnel devoted to EDI function _____

V. Network Service Issues

(21) Do you use a third-party network/service provider?

- yes
 no (skip to question 28)

(22) Who is/are your main network provider(s)? _____

(23) On a scale of A to F (A being excellent, F being poor), please rate the quality of service of your primary third-party network(s).

network 1
 A B C D F

network 2
 A B C D F

network 3
 A B C D F

(24) Are you planning to change networks?

- yes no

If yes, why?

(25) What are the key services of your third-party network that you use?

- Basic services (store and forwarding of messages; compliance checking; monthly audit reports)
 Special advanced services, such as:
 on-line product catalogs
 converting EDI transmissions to paper or fax
 graphics file transfers
 trading partner implementation programs
 others (please list)

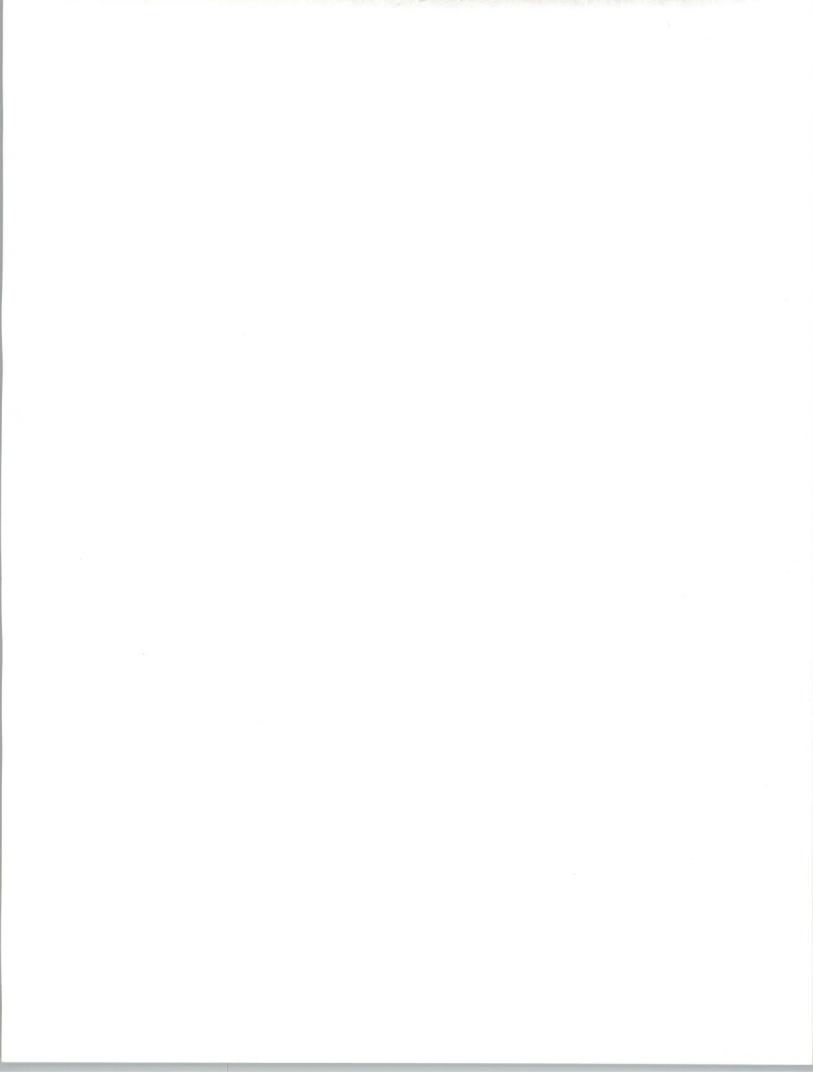

(26) Are you planning to decrease, increase, or keep the same your reliance on third-party value-added networks in the future?

- decrease increase keep the same

If "decrease" or "increase," why?

(27) Are you using interconnection services of your network to reach trading partners with mailboxes on networks other than your own?

- yes no

(28) Is your company considering building its own data communications facility so that you could do EDI directly with trading partners and not use a third-party network?

- considering it
 not considering it
 already doing it
 not sure; possibly

(29) If you are already doing EDI directly, do you foresee in the future:

- completely doing away with third-party network services
 using a combination of third-party services and your own direct network ties
 moving all communications over to a third party

(30) Do you have any need for conducting EDI in a real-time mode instead of a batch mode? Would you like to see in the future some EDI transmissions done in a real-time mode?

- no need
 already doing this
 would like to have real time

(32) Are any other divisions of your company conducting EDI?

- yes, how many ____
 no

(33) Are you using EDI among divisions within your own company?

- yes
 no

(34) Has your company adopted EDI

- for its own strategic reasons
 because customer(s) have requested that it do so

VI. Organizational Impact

The next and last question—I want you to think about how EDI has impacted the way you do things in your organization.

(35) What has been the impact, benefit, and/or difficulties that EDI has brought to your organization?

