

END - USER MICRO-MAINFRAME NEEDS

INPUT

INPUT provides planning information, analysis, and recommendations to managers and executives in the information processing industries. Through market research, technology forecasting, and competitive analysis, INPUT supports client management in making informed decisions. Continuing services are provided to users and vendors of computers, communications, and office products and services.

The company carries out continuous and in-depth research. Working closely with clients on important issues, INPUT's staff members analyze and interpret the research data, then develop recommendations and innovative ideas to meet clients' needs.

Clients receive reports, presentations, access to data on which analyses are based, and continuous consulting.

Many of INPUT's professional staff members have nearly 20 years' experience in their areas of specialization. Most have held senior management positions in operations, marketing, or planning. This expertise enables INPUT to supply practical solutions to complex business problems.

Formed in 1974, INPUT has become a leading international planning services firm. Clients include over 100 of the world's largest and most technically advanced companies.

Offices

NORTH AMERICA

Headquarters
1943 Landings Drive
Mountain View, CA
94043
(415) 960-3990
Telex 171407

Detroit
220 East Huron
Suite 209
Ann Arbor, MI 48104
(313) 971-0667

New York
Park 80 Plaza West-1
Saddle Brook, NJ 07662
(201) 368-9471
Telex 134630

Washington, D.C.
11820 Parklawn Drive
Suite 201
Rockville, MD 20852
(301) 231-7350

S-104 22 Stockholm
Sweden
08-52 07 20
Telex 17041

West Germany
NOVOTRON GmbH
Am Elizabethenbrunnen 1
D-6380 Bad Homburg
West Germany
Telex 418094

AUSTRALIA

Gas Data Service
Company, Ltd.
Mitsui Building
2-7 Kita Aoyama
Chome Minato-ku
Tokyo, 107

00-7090
26487

Shishuto
Suzumaru Bldg., 6th Floor
Shi Shimbashi
Chome Minato-ku
Tokyo, 105, Japan
03-37-0654
03-781 26196

Singapore
Software Consultants (PTE) Ltd.
Pangkor
Singapore Park
Singapore 1025
042

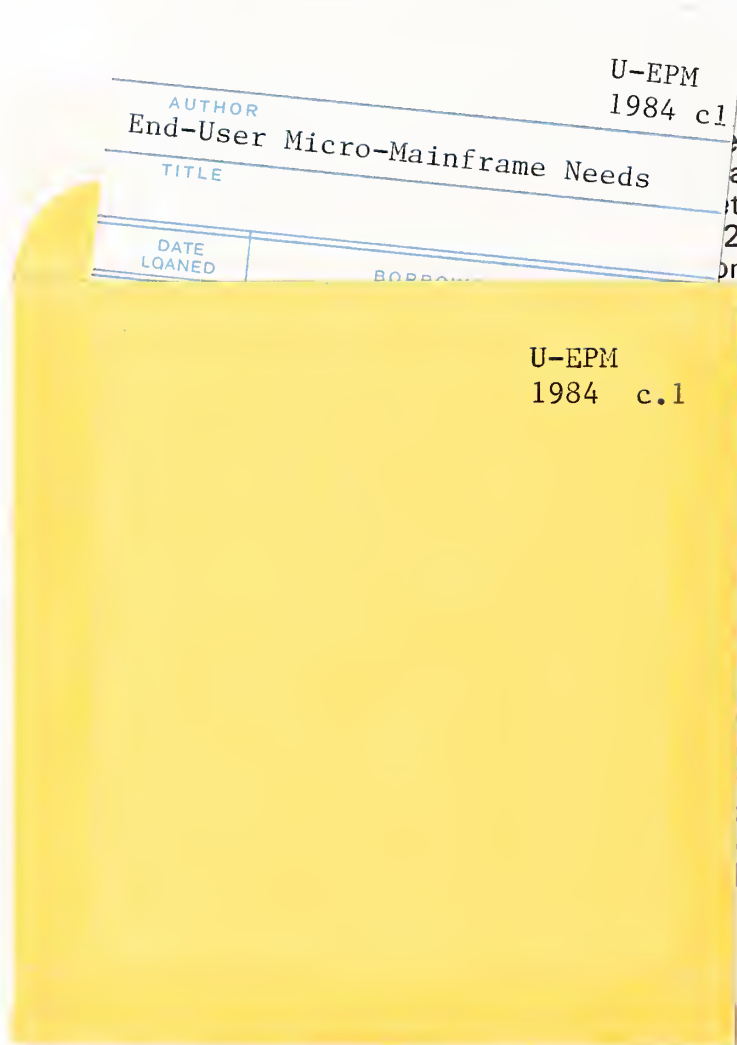

END-USER MICRO-MAINFRAME NEEDS

7

JULY 1984

END-USER MICRO-MAINFRAME NEEDS

ABSTRACT

The micro-mainframe issue has rocketed to prominence, fueled by the profusion of vendor product announcements and an explosive end-user demand. There is a real danger, however, that the issues united under the banner of "micro-mainframe" could produce a discontinuity in data processing at least as large as that produced by the introduction of the System/360.

This report addresses the components of the micro-mainframe phenomenon. The directions of end users are explored through five case studies. The future directions of micro-mainframe products are investigated, and the major technological and planning issues are identified. Recommendations that focus on the technical, end-user, and vendor aspects of micro-mainframe needs are also included.

This report contains 158 pages, including 52 exhibits.

END-USER MICRO-MAINFRAME NEEDS

CONTENTS

	<u>Page</u>
I INTRODUCTION.....	1
A. Background	1
B. Methodology	2
C. Other Related INPUT Reports	8
II EXECUTIVE SUMMARY	13
A. End-User and IS Management Views of the Micro	14
B. End-User and IS Management Views of Micro-Mainframe Linkage	16
C. Micro-Mainframe Applications Growth: 1984-1988	18
D. Shared Functionality: The Goal and the Challenge	20
E. Connectivity Alternatives	22
F. Micro-Mainframe Dangers	24
G. Recommendations	26
III END-USER DIRECTIONS.....	29
A. Introduction	29
B. A Bank's Matrixed Data Base	30
C. The Micro as Change Agent in a Retail Organization	33
D. Order Entry in Chemical and Petroleum Companies	36
E. The UNIX Time Bomb	46
F. An Insurer's Micro-Mainframe Nonconnection	51
G. Summary	55
IV MICRO-MAINFRAME FUTURE DIRECTIONS	59
A. Shared Functionality	59
B. Types of Micro-Mainframe Linkages	64
C. Development Approaches to Micro-Mainframe Applications	75
V MICRO-MAINFRAME ISSUES.....	83
A. Technology Issues	83
1. The XT/370	83
2. UNIX	87
3. Data Synchronization	89
B. Planning Issues	92

	<u>Page</u>
VI RECOMMENDATIONS	97
A. Technical Approaches	97
1. Low Risk: Data Downloading	97
a. An Entry Strategy	97
b. Standards	98
c. The Information Center as a Connectivity Tool	99
2. Low/Medium Risk: Developing an On-Line Batch Strategy	99
3. High Risk: Interactive Applications	101
B. End-User Relationship Building	101
1. General IS-User Relationship Improvements	103
2. PC Services	104
3. Organizational Changes	105
C. Vendor Partnerships	108
APPENDIX A: MICRO-MAINFRAME USER QUESTIONNAIRE	111
APPENDIX B: CORPORATE RESPONDENT PROFILE	123
APPENDIX C: MICRO-MAINFRAME VENDOR QUESTIONNAIRE	125
APPENDIX D: EXCERPTS FROM INPUT'S REPORT, <u>EVALUATING</u> <u>THE EDP LEVEL OF SERVICE</u>	135
A. General Recommendations	135
B. User Service Agreements	137
1. Deciding Where Service Agreements Are Advisable	137
2. Factors Dependent on Information Systems	138
3. User-Related Factors	139
4. Service Agreement Contents	144
5. Developing User Service Agreements	150
6. Information Systems Resources Needed	152
APPENDIX E: EXCERPTS FROM INPUT'S REPORT, <u>SUPPORTING</u> <u>PERSONAL COMPUTER SOFTWARE</u>	153
A. Organizational Size Is a Hidden Factor in the PC Software Experience	153
B. Categories of PC Software Support	154
C. The Greater the IS Resource, the Greater the Potential Benefit	155
D. Determining the Level of Resource: An Art or a Science?	156
E. IS Should Be the Primary Source of Support	157
F. Methods of Financing PC Software Support	158

END-USER MICRO-MAINFRAME NEEDS

EXHIBITS

		<u>Page</u>
I	-1 IBM's PC Communications Framework	3
	-2 Corporate Micro Growth, 1984-1986	4
	-3 Micro-Mainframe Report Relationships	9
II	-1 End-User and IS Management Views of the Micro (1981)	15
	-2 End-User and IS Management Views of Micro-Mainframe Linkage (1984)	17
	-3 Micro-Mainframe Applications Growth: 1984-1988	19
	-4 Shared Functionality: The Goal and the Challenge	21
	-5 Connectivity Alternatives	23
	-6 Micro-Mainframe Dangers	25
	-7 Recommendations	27
III	-1 Central Loan Data Base: Matrixed with PCs	32
	-2 Shifting of Control from Mainframe to Micro	34
	-3 Order Entry Application Components (Logical View)	38
	-4 Current Discount Structure (Logical View): Principal Discount Factors	39
	-5 Current Discount Structure (Logical View): Other Discount Factors	40
	-6 Distributed User View of Order Entry Application	44
	-7 An Unplanned Evolution into a UNIX Environment	47
	-8 An Insurance Company's Micro-Mainframe Nonconnection	54
	-9 End-User Case Study Summary	56
	-10 Differences between Analytic and Production Systems	58
IV	-1 Respondents' View of Shared Functionality	60
	-2 Key IS Managers' View of Shared Functionality	62
	-3 Expectation of Extensive Host-Micro Shared Functionality Application	63
	-4 Attitudes toward Shared Functionality Applications: Selected Groups with Higher than Average Attitudes	65
	-5 Attitudes toward Shared Functionality Applications: Selected Groups with Lower than Average Attitudes	66
	-6 Hierarchy of Micro-Mainframe Connectivity	67
	-7 Types of Micro-Mainframe Linkages Foreseen	69
	-8 Micro-Mainframe Linkage Alternatives	70
	-9 Cullinet Micro-Mainframe Offerings	71
	-10 McCormack & Dodge Micro-Mainframe Offering	72
	-11 Informatics Micro-Mainframe Offering (VisiAnswer)	73

		<u>Page</u>
	-12 Comshare's System "W"	74
	-13 Interactive versus On-Line Batch Micro-Mainframe Applications: Corporate and Vendor Views	76
	-14 Development Strategies for Applications Software for Micro-Mainframe Systems: Corporate and Vendor Views	77
	-15 Extent to Which a Particular Development Strategy Supports Other Strategies	79
	-16 Vendor Involvement in Micro-Mainframe Applications	80
V	-1 Future Importance of XT/370 to Selected Groups	88
	-2 XT/370 and UNIX: Future Importance and Current Understanding	90
	-3 Problems in Micro-Mainframe Connectivity	91
	-4 Adequacy of System Implementation Approaches	96
VI	-1 On-Line Batch-Data Transfers	100
	-2 Data Base Post-Processor: Limits Excessive Micro Independence	102
	-3 Organizational Evolution into the Micro-Mainframe Environment (Phase 1)	106
	-4 Organizational Evolution into the Micro-Mainframe Environment (Phase 2)	107
	-5 Organizational Evolution into the Micro-Mainframe Environment (Phase 3)	109
D	-1 Organizational and Information Systems Factors Affecting Advisability of Introducing Service Agreements	140
	-2 Distinguishing Key Users from Other Users	142
	-3 User-Related Factors Affecting Advisability of Introducing Service Agreements	145
	-4 Service Agreement Content: Terminal Downtime Checklist	147
	-5 Service Agreement Content: Response Time Checklist	148
	-6 Service Agreement Content: Program Development Request Checklist	149
	-7 Steps in Developing User Service Agreements	151

I INTRODUCTION



Digitized by the Internet Archive
in 2014

I INTRODUCTION

A. BACKGROUND

- The micro-mainframe issue is one that scored high in INPUT's 1983 client poll. Since then, interest has continued to climb, assisted by a barrage of vendor announcements.
- However, the profusion of announcements of products (and some pseudo-products) has made it in some ways more difficult to identify and understand the real issues. Most current vendor products and corporate plans are preliminary, where they are not primitive.
- INPUT believes that the group of issues united under the banner "micro-mainframe" could produce a discontinuity in data processing at least as large as that produced by the introduction of the System/360. With this view, the micro-mainframe question becomes much more than a question of, for example, screen versus file transfer.
- INPUT intends that the studies contained in this series of reports (see section C of this chapter) be useful planning documents over a three- to five-year planning horizon, although the reports do not neglect current issues or technical detail.

- The study generally assumes that the micro-mainframe world is an IBM world (or an IBM-compatible world, which in many ways is the same thing). This has obviously been true for some time at the mainframe level and the issue will not be belabored here.
 - At the micro level this assumption is still somewhat debatable; for example, Apple's Macintosh and ATT's recently announced computer series may still provide a basis for corporate micro-mainframe strategies. However, two key points should be made:
 - IBM's current interconnect strategy will provide an underlying environment for Information Systems (IS), end users, and vendors, as shown in Exhibit I-1.
 - Equally important is the view held by IS departments. The non-IBM-compatible share of corporate micros is expected by IS management to be very low compared to IBM and IBM-compatibles, as shown in Exhibit I-2.
 - This does not mean that there is not and will not be a place for innovative micro hardware in large enterprises. However, from the standpoint of micro-mainframe connectivity, such devices will have to look like comparable IBM-compatible equipment in order to be easily used and accepted; or at least they must be transparent to IBM networks.

B. METHODOLOGY

- The research for this report was conducted in parallel with that for three related reports (see next section). A large project team spent over four months researching and analyzing information in this rapidly changing area. The research consisted of the following major activities:

EXHIBIT I-1

IBM'S PC COMMUNICATIONS FRAMEWORK

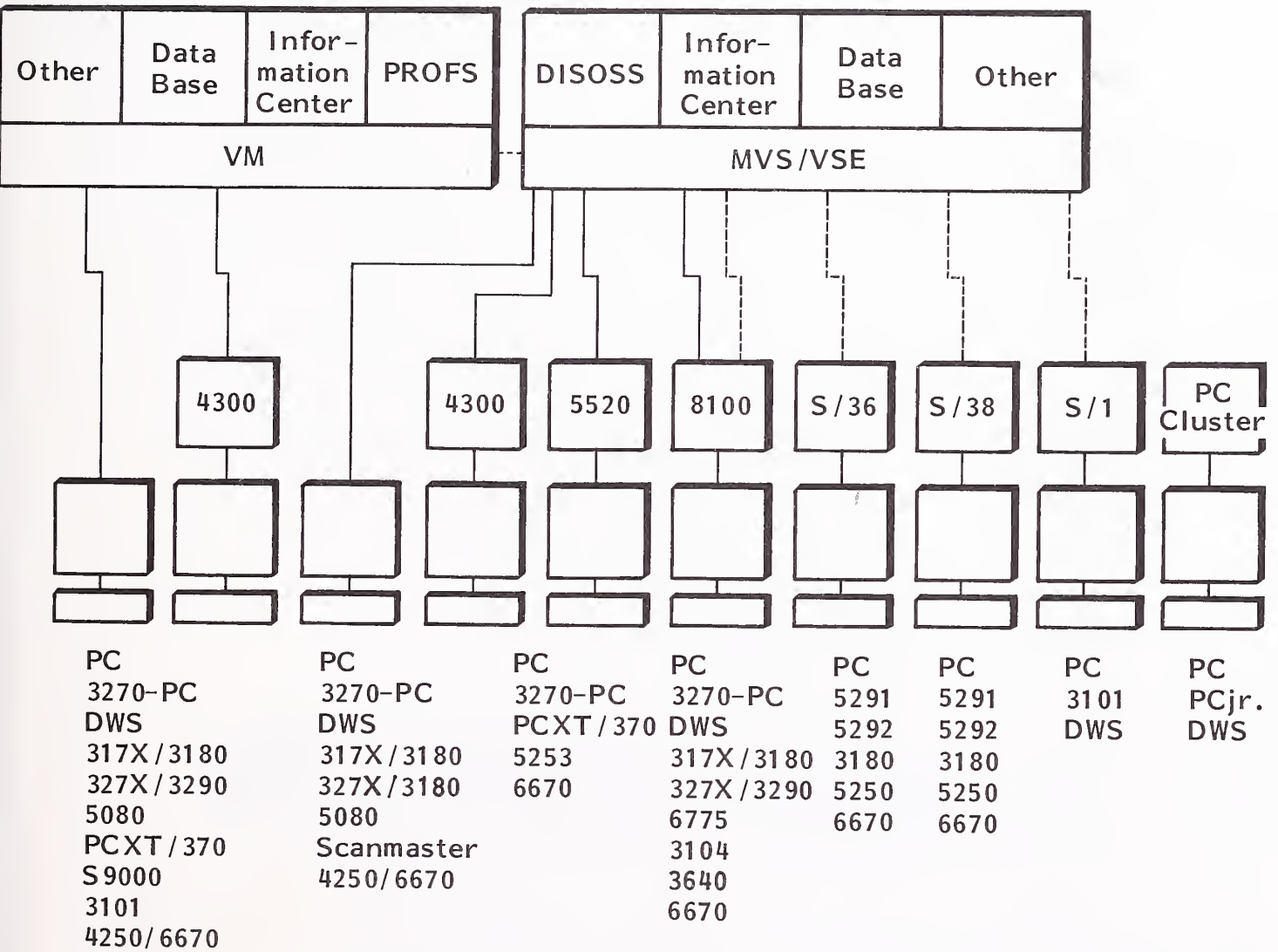

Source: IBM

EXHIBIT I-2

CORPORATE MICRO GROWTH, 1984-1986

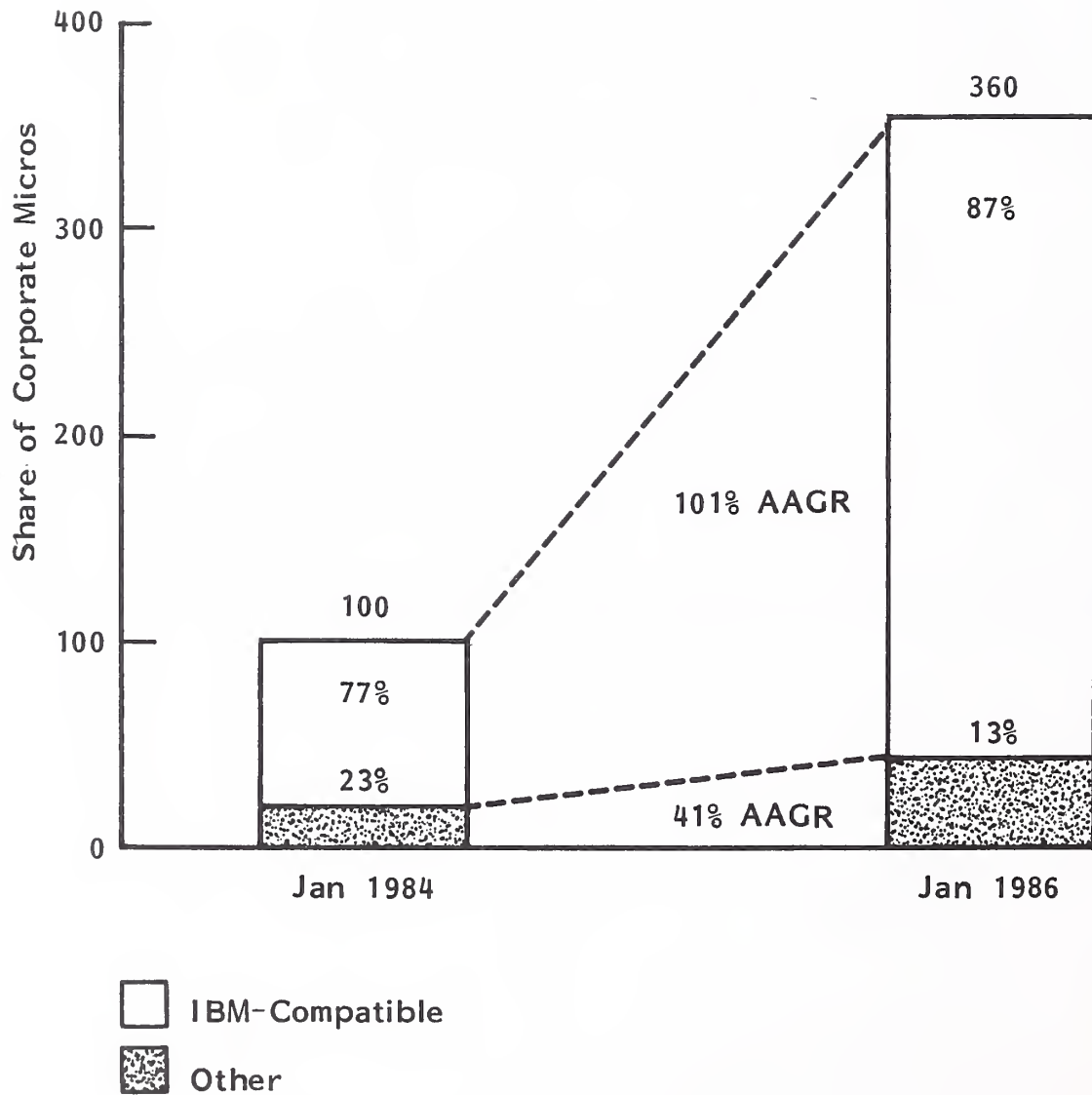

- Client interviews.
 - Corporate interviews, case studies, and consulting.
 - Vendor interviews, case studies, and consulting.
 - Product and service analyses.
- Client interviews.
 - INPUT clients were sampled in December and January to ascertain their areas of special interest and to learn of their experiences, problems, and needs.
- Corporate interviews.
 - Seventy-eight structured interviews were conducted with IS management at large companies in February and March of 1984.
 - The questionnaire used is in Appendix A.
 - Company sizes and industries are shown in Appendix B.
 - These interviews were unusual, owing to the fact that they were much longer than typical interviews (i.e., averaging 45 minutes to over an hour); respondents were highly motivated and forthcoming.
 - In addition, INPUT had the opportunity to review over 20 companies in depth. Some of the experiences of these companies are described in the reports in detail; other information was used to inform our analysis and recommendations.

- In the past nine months, INPUT has conducted a number of consulting studies that bear on the micro-mainframe issue. Five of these studies have specifically addressed micro-mainframe issues from the corporate standpoint, and the knowledge gained is relayed in this report.
- Vendor interviews.
 - Structured interviews were conducted with vendor personnel from 20 companies in February and March. The questionnaire used is shown in Appendix C.
 - In addition, more than 30 other people from vendor organizations were interviewed in particular issue areas.
 - Vendors, too, were highly interested in the topic and were quite forthcoming. A number of interviews were multihour in length. Those interviewed ranged from senior technical staff to company presidents. The companies included small, innovative software firms and very large hardware companies.
 - INPUT's recent consulting studies have included four that address vendor micro-mainframe issues. Although no proprietary information from these engagements was used directly for these public studies, these engagements provided INPUT with an in-depth sensitivity to vendor requirements.
- Product and service analysis.
 - INPUT has collected and analyzed information on several hundred products and services in the micro-mainframe area.
 - Unfortunately, some of the information obtained at the beginning of the study is already obsolete. INPUT estimates that micro-mainframe

technical and product information has a half-life of about six months. Several products will probably be formally available a short time after the release of this report. The rate of new product introduction has been very high, and INPUT expects it to continue; for example, there are high-speed micro-mainframe links from LAN vendors, and Cullinet has a micro-mainframe intelligent link.

- In general, micro-mainframe products are evolving very quickly. Consequently, extensive detailed product comparisons will soon be out of date.
- Therefore, INPUT has used specific products largely to illustrate more basic issues. INPUT's goal has been to make this a study that would require only marginal updating for it to remain a useful planning tool a year from now.
- Some of the survey's quantitative results would have appeared surprising, even dubious, to the INPUT micro-mainframe project team had it not been for other micro-mainframe-related studies that INPUT has conducted in the past six months.
 - Several of these other studies included in-depth (i.e., one to two hours), face-to-face interviews conducted with:
 - Over 50 IS managers and planners.
 - Over 25 people in end-user management (up to the executive vice president level in multibillion-dollar organizations).
 - These other studies are very supportive of the projections contained here and, from the standpoint of end-user motivations and plans, may even go beyond some of the findings here.

- Although the companies interviewed for this report were selected randomly, in a sense the respondents were not. But respondent self-selection has worked to the study's benefit, in INPUT's opinion.
 - Respondents were in IS executive or planning management, and the job titles have the usual distribution for this type of study.
 - However, in arranging interviews, INPUT was usually (and properly) directed to the person that was most knowledgeable on micro-mainframe issues in that organization.
 - This person was almost always ahead of the rest of the organization in information and, more importantly, in insight. These respondents often know where their IS organizations are going before most others in the organization have even begun to consider the issues.
 - Fortunately, this brings the results of the survey much more in synch with end-user directions and motivation. (For obvious reasons, it is very important to understand where end users are going.)

C. OTHER RELATED INPUT REPORTS

- This report is being issued in conjunction with three other reports in the micro-mainframe series of reports, as shown in Exhibit I-3. These reports are:
 - Micro-Mainframe: Communications Issues
 - This report is part of the Information System Program (ISP) that is utilized by IS management.

EXHIBIT I-3

MICRO-MAINFRAME REPORT RELATIONSHIPS

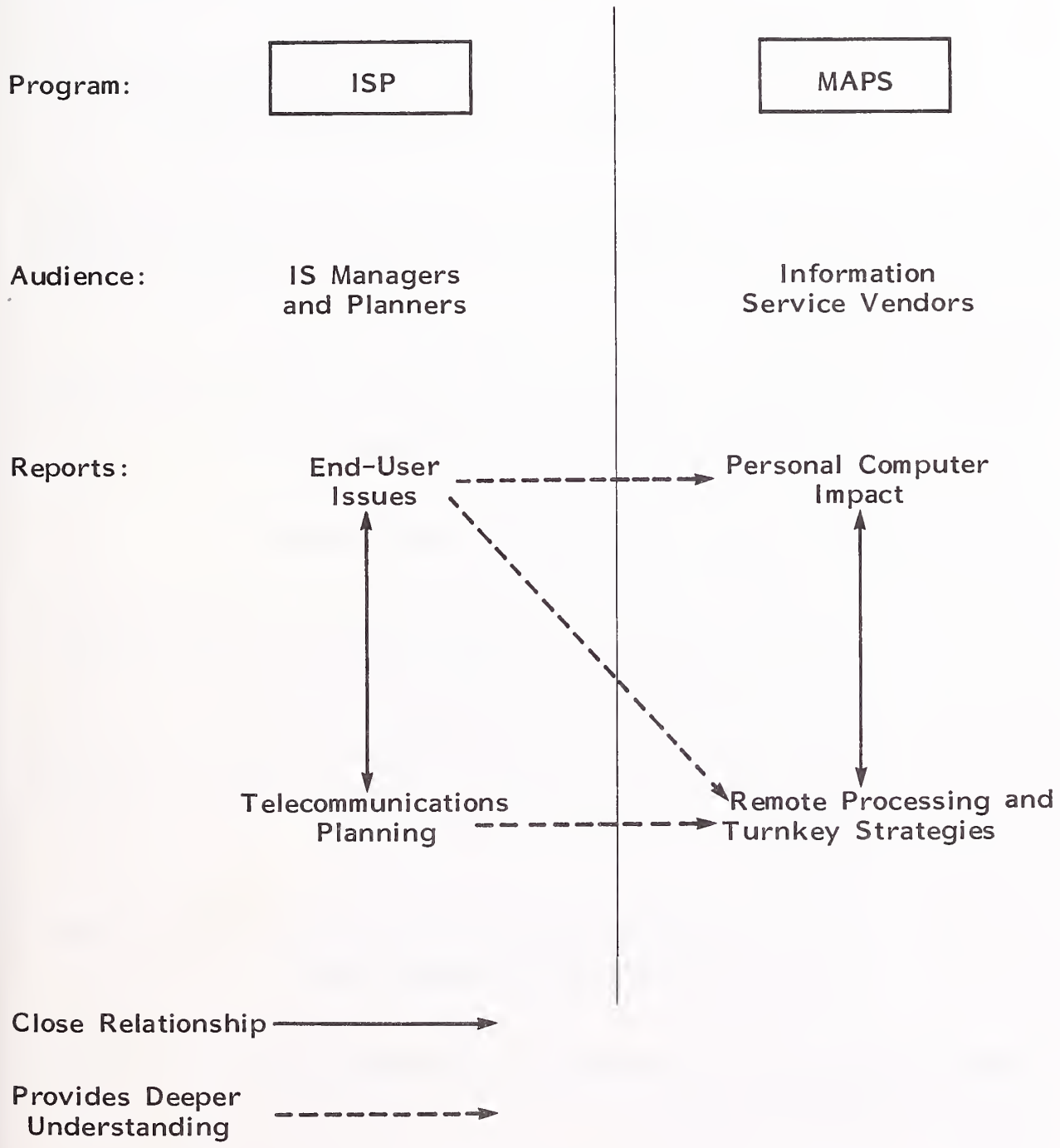

- This study addresses current developments as well as future trends in micro-mainframe communications.
 - The micro promises to have a significant impact on communications. This report analyzes positive and negative effects of these changes and provides strategies for dealing with them.
- Micro-Mainframe: Personal Computer Impacts
 - This report is part of the Market Analysis and Planning Service (MAPS) that is utilized by information service vendors.
 - The study addresses and analyzes micro-mainframe developments and the impact they will have on the personal computer industry.
 - The report provides market forecasts and strategies for taking advantage of coming structural changes.
- Micro-Mainframe: Processing and Turnkey Strategies
 - This report is part of the Market Analysis and Planning Service (MAPS) program that is utilized by information service vendors.
 - This study analyzes micro-mainframe developments from the standpoint of their effect on traditional RCS and turnkey services.
 - The report provides market forecasts and strategies for adapting to a rapidly changing set of customer needs.
- These four reports share a common core of concepts, and data is presented to readers in the following way:

- The reports avoid (when possible) referring readers to pertinent sections of other reports, in order to make each report stand on its own.
- Data analyses or concepts that are discussed in more detail in other reports are summarized.
- Detailed information is included in appendices.
- Other related INPUT reports include:
 - Selecting User Friendly Operating Systems for Personal Computers, June 1983.
 - Executive Workstation Acceptance: Problems and Outlook, May 1984.
 - Organizing the Information Center, August 1983.
 - Supporting Personal Computer Software, August 1983.
 - Data Administration: Experiences and Outlook, June 1984.
 - Personal Computers in the I.S. Strategy, December 1982.

II EXECUTIVE SUMMARY

II EXECUTIVE SUMMARY

- This executive summary is designed in a presentation format in order to:
 - Help the busy reader quickly review key research findings.
 - Provide an executive presentation and script that facilitates group communications.
- The key points of the entire report are summarized in Exhibits II-1 through II-7. On the left-hand page facing each exhibit is a script explaining the exhibit's contents.

A. END-USER AND I.S. MANAGEMENT VIEWS OF THE MICRO

- Micros were viewed quite differently by end users and IS managers when they first began to appear on the corporate scene.
- End users saw the personal computer (PC) as a great breakthrough that allowed them to take charge of considerable amounts of their data processing destiny. The PC was:
 - Responsive: Jobs could be accomplished literally overnight without being filtered through intermediaries.
 - Flexible: Users were not locked into a particular approach but could build what were, in reality, prototypes.
 - Self-directed: Perhaps most important was being able to directly integrate and control data processing support.
- Even the Information Center (which did not exist at that time in many organizations) could not provide this kind of control.
- Many IS managers were unaware of the micro phenomenon. Others did nothing, and some viewed the micro as a threat to orderly data processing.
- Toward the end of the early micro period, many IS departments recognized the micro and took steps to control, or at least to coordinate, its use.
- Most IS managers agree that their PC actions have been reactive and have generally not been a major influence on the amount or extent of end-user PC use.

END-USER AND I.S. MANAGEMENT VIEWS OF THE MICRO (1981)

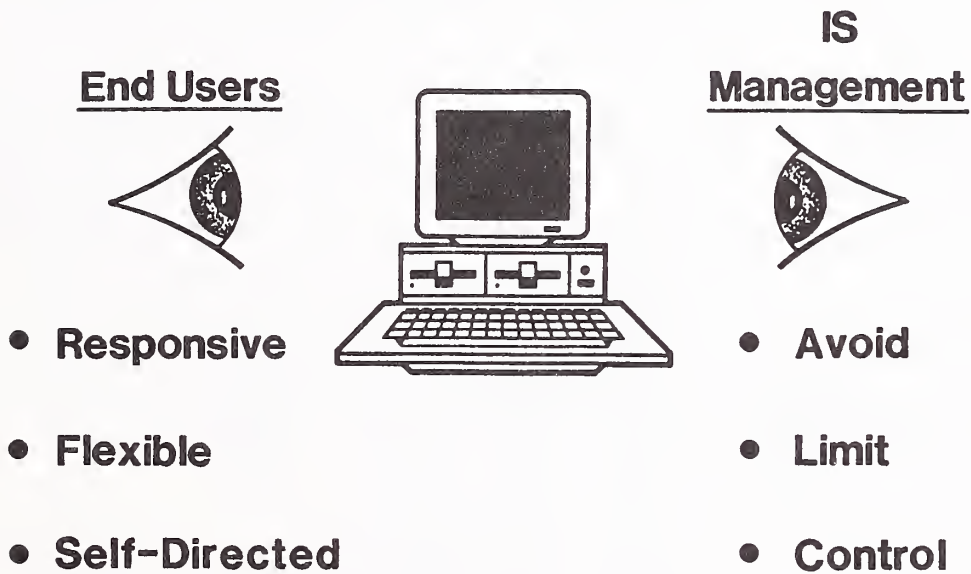

B. END-USER AND I.S. MANAGEMENT VIEWS OF MICRO-MAINFRAME LINKAGE

- History may be about to repeat itself with regard to micro-mainframe linkage. However, there are much greater dangers from missteps in handling micro-mainframe issues, largely because end users and IS must work well and closely together if micro-mainframe efforts are to be successful.
- Most IS departments still see the micro-mainframe issue as business as usual. Looking at the situation from IS's standpoint, control (i.e., restriction of access) becomes more important so that end users do not disrupt the operational system. Consistent with control, data generally flows downward, usually from file extracts. IS implicitly assumes that this data will generally be put to analytic use. That is, the next generation in connectivity will be supporting the next generation of spreadsheets.
- There is much to be said for this viewpoint, since this is the sort of activity that current vendor products are supporting. Also, most end users with some kind of micro-mainframe linkage are generally using downloaded data for analysis.
- However, INPUT's research and analysis strongly indicate that the picture is already very different in the minds of many end users. They see micro-mainframe links as providing not just the relatively limited self-direction they have with standalone micros, but also the potential for much greater self-determination. This means having two-way data flow.
 - Not surprisingly, given this view, users will increasingly be viewing operational and analytic use interchangeably.

END-USER AND I.S. MANAGEMENT VIEWS OF MICRO-MAINFRAME LINKAGE (1984)

End Users



- **Self-Determination**
- **Two-Way Data**
- **Operations and Analytic Use**

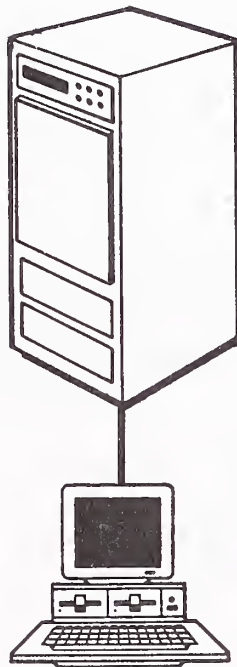

IS Management



- **Control**
- **One-Way Data**
- **Analytic Use**

C. MICRO-MAINFRAME APPLICATIONS GROWTH: 1984-1988

- INPUT forecasts that by 1988 about a quarter of installed mainframe applications will be micro-mainframe applications.
 - The potential range is from 20% to 35%.
 - In type and complexity, these applications will be representative of today's host applications; hence these figures generally will be representative of processing requirements as well.
 - Projections were based on INPUT's assessment of the likelihood of implementation plans being achieved and the attitudes toward micro-mainframe applications on the part of the corporations interviewed.
- This level of growth means that data processing systems will look far different in five years. Planners must prepare their IS organizations for great changes. These changes will have significant impact on:
 - The technical nature of systems.
 - The IS organization and IS relations with end users.
 - In many cases, the way in which a corporation conducts its business.
- Before examining these impacts, two key attributes of "micro-mainframe applications" should be examined further. These are:
 - Shared functionality.
 - Connectivity alternatives.

MICRO-MAINFRAME APPLICATIONS GROWTH: 1984-1988

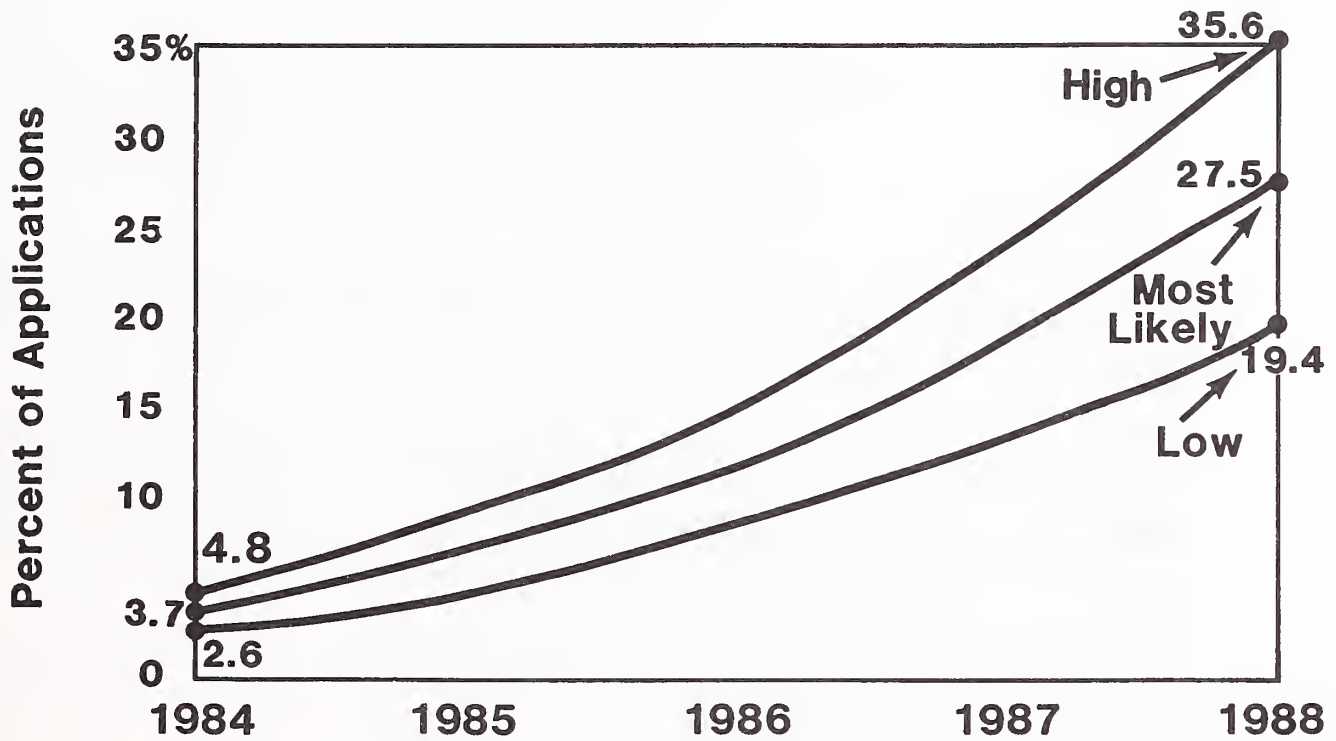

D. SHARED FUNCTIONALITY: THE GOAL AND THE CHALLENGE

- INPUT has coined the term "shared functionality" to describe micro-mainframe applications where a data processing activity cannot be carried out without processing and/or data being shared by both the mainframe and micro.
- This view of shared functionality is held by 85% of INPUT's respondents when referring to "micro-mainframe applications."
- Even more important is the fact that three-quarters of respondents see most applications that are now host-based as having this kind of shared functionality in three to five years.
- Shared functionality promises revolutionary changes for computer systems and their implementation.
- Although most end users do not express themselves in technical language, when they are presented with this kind of diagram illustrating shared functionality, they say, "Of course this is what we want."
- There are serious technical issues to be overcome, however. These are discussed in the next two sections.

SHARED FUNCTIONALITY: THE GOAL AND THE CHALLENGE

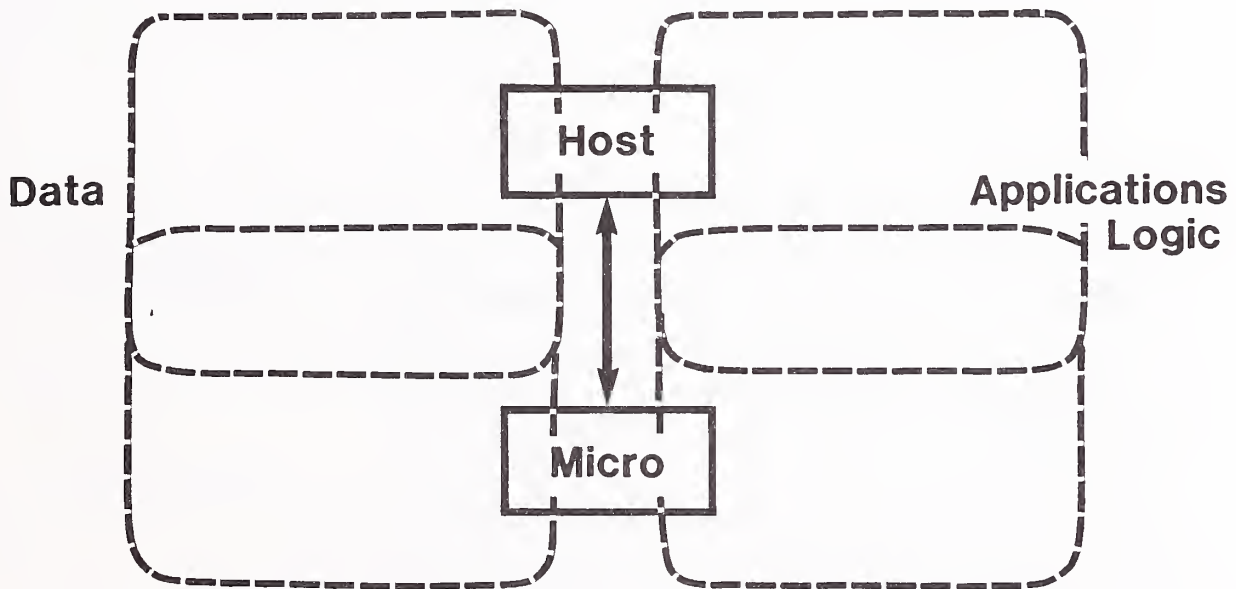

E. CONNECTIVITY ALTERNATIVES

- The interactive approach to connectivity is virtually impossible to achieve, given today's technical constraints.
 - In spite of that, three-quarters of INPUT's survey respondents believe the interactive mode will be used at least half the time.
 - It should be stressed that these were informed IS planners and managers, so obviously they were looking beyond what exists now, to what will--or should--exist in the future.
- In the short run, only on-line batch systems will be feasible. However, on-line batch applications will often appear to end users as being virtually interactive. The key issue is whether some of the micro-accessed data must be identical to that at the host level or whether data that is periodically re-freshed will serve just as well.
 - This is a key issue and should be the foundation of all micro-mainframe data analysis. This distinction has not had to be made for most current interactive systems, since the choices are generally between totally on-line or classical batch implementations.
 - Micro-mainframe systems will introduce an intermediate class of data and data analysis.
 - In the long run, when true interactive systems are possible, they may well make use of such resource-hungry tools as relational data bases. Consequently, the on-line batch approach will always have efficiency attractions. In addition, on-line batch applications will be easier to design and construct since many good design concepts such as restricted entry and exit points in modules will be enforced by the physical separation of devices.

CONNECTIVITY ALTERNATIVES

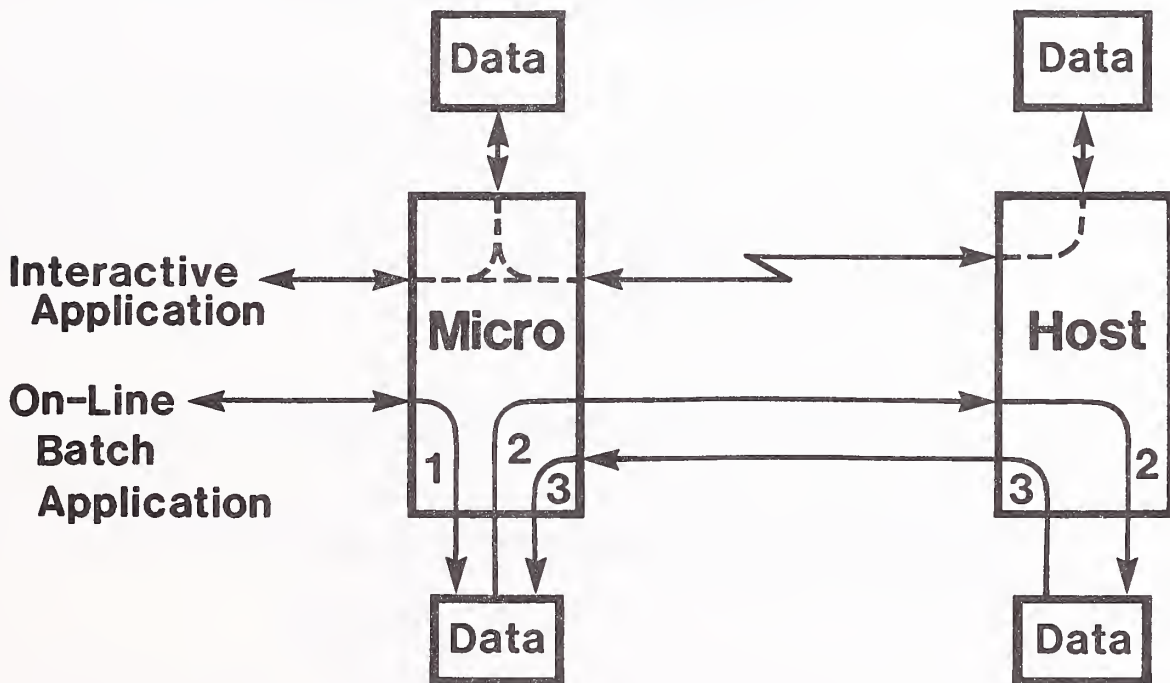

(Numerals refer to steps.)

F. MICRO-MAINFRAME DANGERS

- The danger of attempting interactive micro-mainframe applications prematurely has already been described. There are other large dangers in micro-mainframe applications, especially those that are poorly thought through.
 - Linking data across applications will become increasingly difficult if, as expected, local micro users will modify their data structures to best meet their local needs.
 - Security is something that even mainframe applications often only pay lip service to, depending excessively on whatever is built into applications packages or supplied in access control packages. Both physical security and data synchronization problems will develop new dimensions in a micro-mainframe environment.
 - Micro systems are noted for their flexibility. But by becoming connected to host-based systems they must give up at least part of this flexibility; the goal of designers will be to make this loss as small as possible.
 - Similarly, in a micro-mainframe application, neither the end user nor IS will have sole control. This can be disastrous where the two groups have different priorities or have not learned how to work together.
- A hidden danger is that current design and implementation policies usually will become obsolete or obsolescent in a micro-mainframe environment. Unfortunately, each IS group (for the time being) will have to devise a satisfactory methodology for itself.

MICRO-MAINFRAME DANGERS

- **Data Base Linkages**
- **Security**
- **Loss of Flexibility**
- **User versus IS Control**
- **Design and Implementation Changes**

G. RECOMMENDATIONS

- Users should be educated on IS technology and issues. A general confidence-building strategy is also needed. This strategy may include: regular, informed, face-to-face meetings between IS management and its peers; a frankness in admitting IS problems and deficiencies; and objective ratings of IS performance.
- IS should take steps to gain a deeper understanding of the company's (and individual department's) key business goals, motivations, and problems.
- The IS PC support unit should be expanded to include all the functions outlined in INPUT's report, Supporting Personal Computer Software, August 1983. This is the most effective means for creating a deep understanding of micro opportunities and limitations.
- IS should initiate low-risk micro-mainframe projects as a learning tool and a confidence builder.
- Micro-mainframe initiatives may accelerate full or partial decentralization of applications-oriented functions to user departments. If not planned, such decentralization could have negative effects on both organizational and applications effectiveness.
- Because of the technical difficulties in moving into a true micro-mainframe environment, IS should enter into informal (or, if warranted, formal) arrangements with one or more vendors to find technical solutions to micro-mainframe issues.

RECOMMENDATIONS

- **User-IS Relationships**
 - **IS: Business Orientation**
 - **Users: Knowledge and Confidence**

- **PC Support Unit**

- **IS Initiatives: Easy Projects**
 - **Experience**
 - **Confidence Building**

- **Consider Decentralization**

- **Experiment with Vendors**

III END-USER DIRECTIONS

III END-USER DIRECTIONS

A. INTRODUCTION

- Much attention has been focused on downloading data to spreadsheets and other micro programs. Several dozen such products have been released and are in users' hands, and at least as many more have been announced or are in beta testing.
 - Many of these products are certainly valuable tools, especially since the prior alternative was to manually key data (often from reports produced from mainframe systems). Manual rekeying is probably still the most prevalent form of micro-mainframe (M-M) interface.
 - However, it became clear in the course of the study that end users already have their sights raised considerably higher than getting extracts of mainframe data to use in calc programs.
- Since this assertion may be difficult for some IS managers to accept, INPUT has developed case studies describing how six companies are attempting to push the edge of the feasible, from an M-M standpoint.
 - In some instances, details of the cases have been altered slightly to preserve anonymity. Commercial and vendor names have been omitted unless they are considered generic (e.g., the PC/XT or UNIX).

- At the end of each study, the salient findings are summarized.
- In the final section of this chapter, commonalities and differences between these M-M initiatives are described and analyzed, and overall conclusions are drawn.

B. A BANK'S MATRIXED DATA BASE

- A major bank's loan portfolio is kept in a centralized data base. The data in the loan portfolio must continually be consulted, analyzed, and updated by two principal types of users:
 - Loan teams--involved in procuring broker loans, real estate loans, offshore loans, commercial and industrial loans (e.g., energy, manufacturing, transportation), etc.
 - Portfolio management--cutting across loan areas to perform functions such as:
 - Reporting.
 - Auditing.
 - Collateral evaluation.
- These specialists have done their jobs in the past using a combination of terminal access and computer-generated reports. Over a year ago minicomputers were installed to download the broker and real estate portions of the data base so that these portions could be used directly by loan teams.

- The minicomputers have proved to be quite successful, although the bank realizes that the application could as easily have been accomplished using PCs. The bank plans to "matrix" the central data base using PCs, as shown in Exhibit III-1.
- In many respects the PC alternative is seen as more attractive because of lower costs and because of the wide availability of packaged software readily usable by end users.
- The PC would be used to originate changes to the central loan data base, but this would not be uploading in the file transfer sense. Rather, the PC would originate transactions for entry through the conventional host system.
 - This is considered necessary for control and security.
 - Because this is a "matrixed" file, it is critical that the central file always be both the real and the official file. Otherwise, the portfolio management functions would be ineffective.
- However, the approach of mimicking traditional file transactions is felt to be too simplistic by some of the bank's systems planners. Some of the advanced proposals include:
 - Using the XT/370 as the user PC (which shows a lack of understanding of the XT/370's capabilities, as discussed in Chapter V).
 - Using a large PC or a small mini as a system controller between the PCs and the host system.
 - Writing a parameter-driven package for reformatting data between the mainframe and PC, and deciding which data would be passed to the portfolio management subsystems.

EXHIBIT III-1

CENTRAL LOAN DATA BASE: MATRIXED WITH PCs

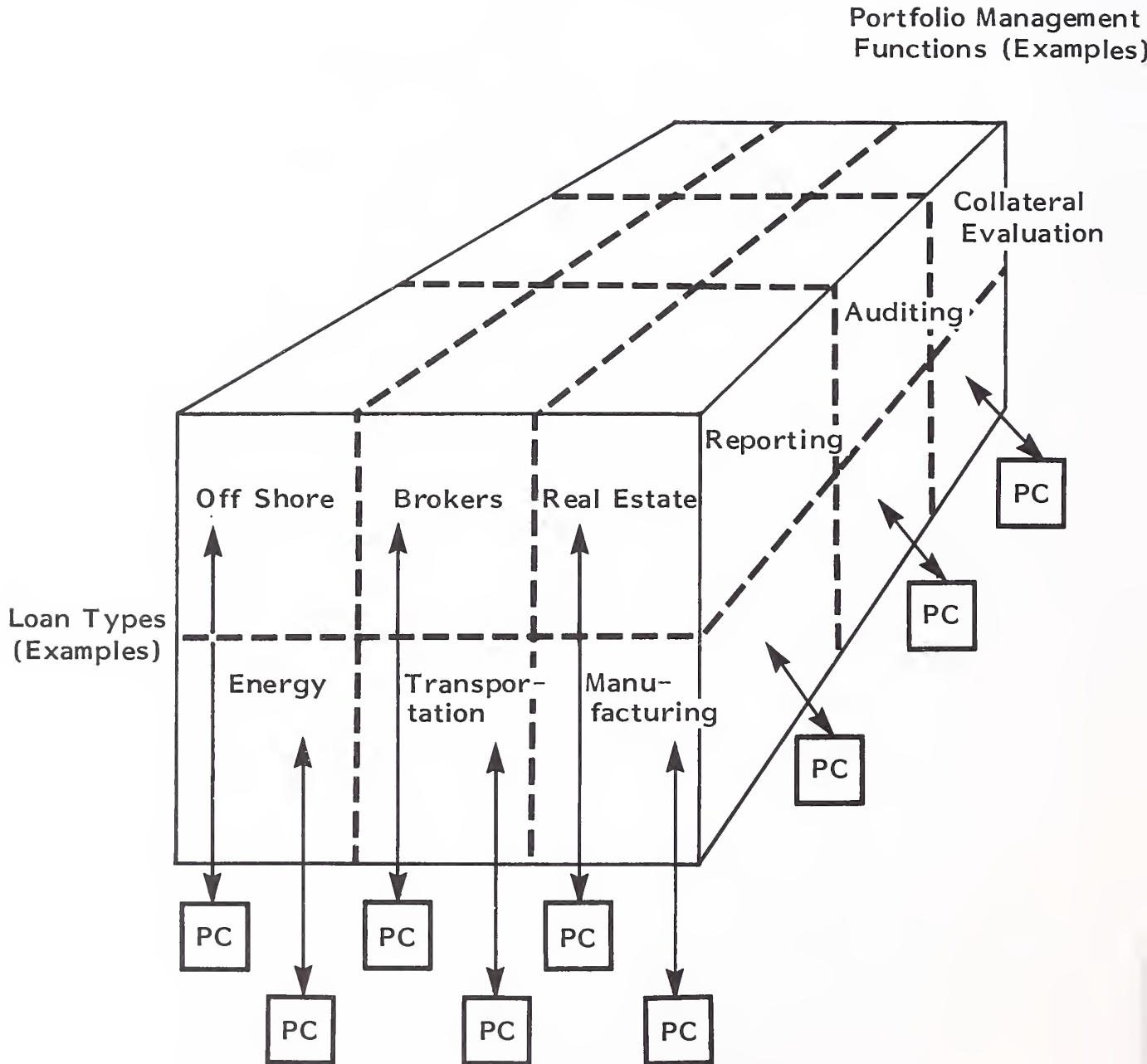

Loan Team PC Functions (Examples):

- Update
- Validate
- Inquiry

- . This package would be designed to be reusable in other bank systems with similar needs.
- . However, by greatly (and needlessly) increasing the number of interfaces, the complexity of resulting systems would decrease security and probably render the software design unfeasible.
- Conclusions: The system as planned will undoubtedly be a success, because it is an evolutionary increment over prior systems.
 - Users and IS have learned to work well together.
 - While the IS technical staff would like to try out more "interesting" solutions, these are not used until proven.

C. THE MICRO AS CHANGE AGENT IN A RETAIL ORGANIZATION

- A large retail store has recently been upgrading its centralized hardware and software. Consequently, IS management has not paid much attention to the Merchandising Department's parallel acquisition of an IBM PC/XT.
 - IS believes that the XT will be used by Merchandising only for producing better ordering estimates to be used by the host-based purchasing/inventory management system, as shown in Exhibit III-2.
 - However, the merchandising unit believes the XT will finally give them a chance to really know the status of orders.
- From the users' standpoint the problem with the host-based system is that it does not (and perhaps cannot) present an accurate view of the order situation during peak periods.

EXHIBIT III-2

SHIFTING OF CONTROL FROM MAINFRAME TO MICRO

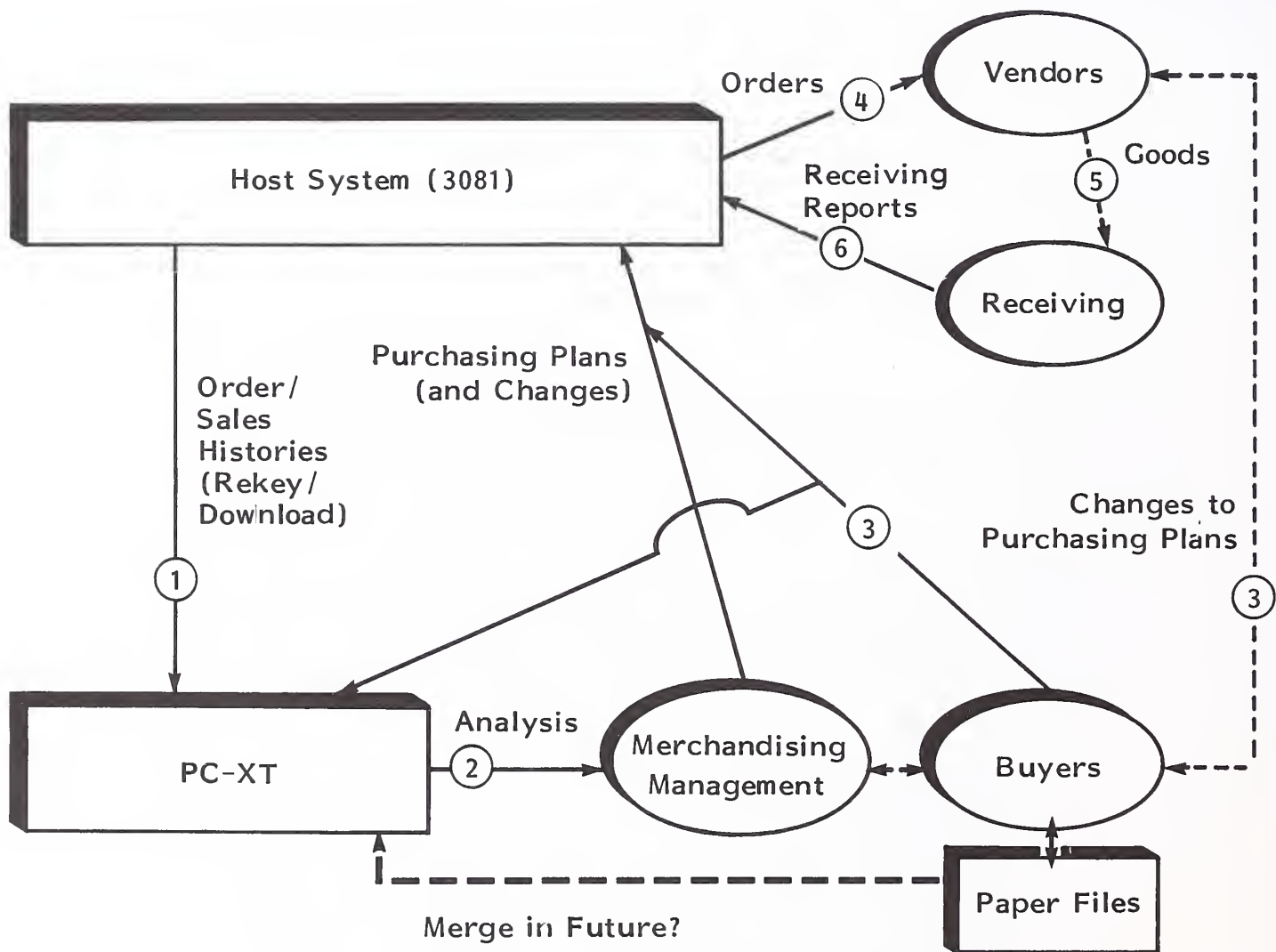

Computer System Related Data Flows _____

Human Communications - - - - -

Other Flows - - - - -

Numerals indicate processes

- Although data is collected via terminals, the core system is really a batch system. The purchase authorization/order cycle can easily take a week before Merchandising knows that an order was received by a vendor. Transaction failures, corrections, and errors in any number of places make the system virtually unusable as an operational or management tool.
- The buyers within the Merchandising Department, in consequence, have always maintained their own paper files to tell them what is really happening.
- The XT has become the system that is used for both analysis and operation by the Merchandising Department. There is even a good chance that the buyers will merge some or all of their paper files with the XT files as buyers become comfortable with the XT. This evolving situation leaves IS in a difficult position.
 - The host system will not be completely replaced. Its central accounting and payables functions will remain. However, its perceived added value will be relatively low.
 - The Merchandising Department will tend to neglect host transactions in favor of XT transactions wherever there is a time or resource conflict. This will create increasing numbers of impurities in the central data base. This will be accentuated by the decreasing use of centrally prepared data by informed users so that data or processing anomalies will not be identified quickly (or at all). The corporate data base will be devalued valueless.
 - Since the Merchandising Department is highly motivated, the XT approach stands a good chance of success. To the extent that Merchandising is successful, the 3081 will become a sort of backend to

the XT. IS may find it embarrassing to justify the significant increase in the expense of central data processing, as a result of the new systems just added.

- Both IS and general management are virtually oblivious to these problems.
 - Both are supportive of Merchandising's efforts to be "modern."
 - IS management is essentially technically oriented. IS does not understand how retail buyers must function.
- Conclusions: This project could become a success in spite of the technical pitfalls lying ahead.
 - The end users want it to work and have clearly defined their own needs.
 - It is more likely, however, that Merchandising in meeting its own needs will needlessly damage the integrity of corporate data.

D. ORDER ENTRY IN CHEMICAL AND PETROLEUM COMPANIES

- Order entry is the critical operational underpinning to a company's marketing and financial success. However, people sometimes underestimate (or are unaware of) the complexity of many of the large computerized order entry systems that have been implemented in recent years.
 - This ignorance of the complexity of underlying system and user needs among otherwise informed users, coupled with a sometimes naive belief in the powers of the PC, will cause increasing problems for some companies.

- This is the case for two large firms (a specialty chemical manufacturer and a petroleum product producer) INPUT interviewed. In both cases a sophisticated centralized order entry system has been developed over the last decade.
- Exhibit III-3 shows the main components of these order entry systems. These systems and their resulting problems are quite similar in their general design and operation, and will be discussed jointly below.
 - Note that "order processing" is only one of the system's functions and, arguably, not the most important one.
 - The order entry system is closely tied to several financial systems.
 - The order entry process is increasingly seen as a logical extension of the production process--both the frontend (production planning) and the backend (shipping and inventory).
 - A very sophisticated set of data bases has been developed to support the order entry process:
 - Complex product and customer directories (coded information on subsidiaries, plant locations, even building and loading dock locations) have been developed.
 - Because of increasing price competition, the sales and marketing departments have developed an increasingly complicated, not to say confusing, set of discount arrangements. IS has successfully been able to capture this in computer logic (which is often changed), as shown in Exhibits III-4 and III-5.

EXHIBIT III-3

ORDER ENTRY APPLICATION COMPONENTS (LOGICAL VIEW)

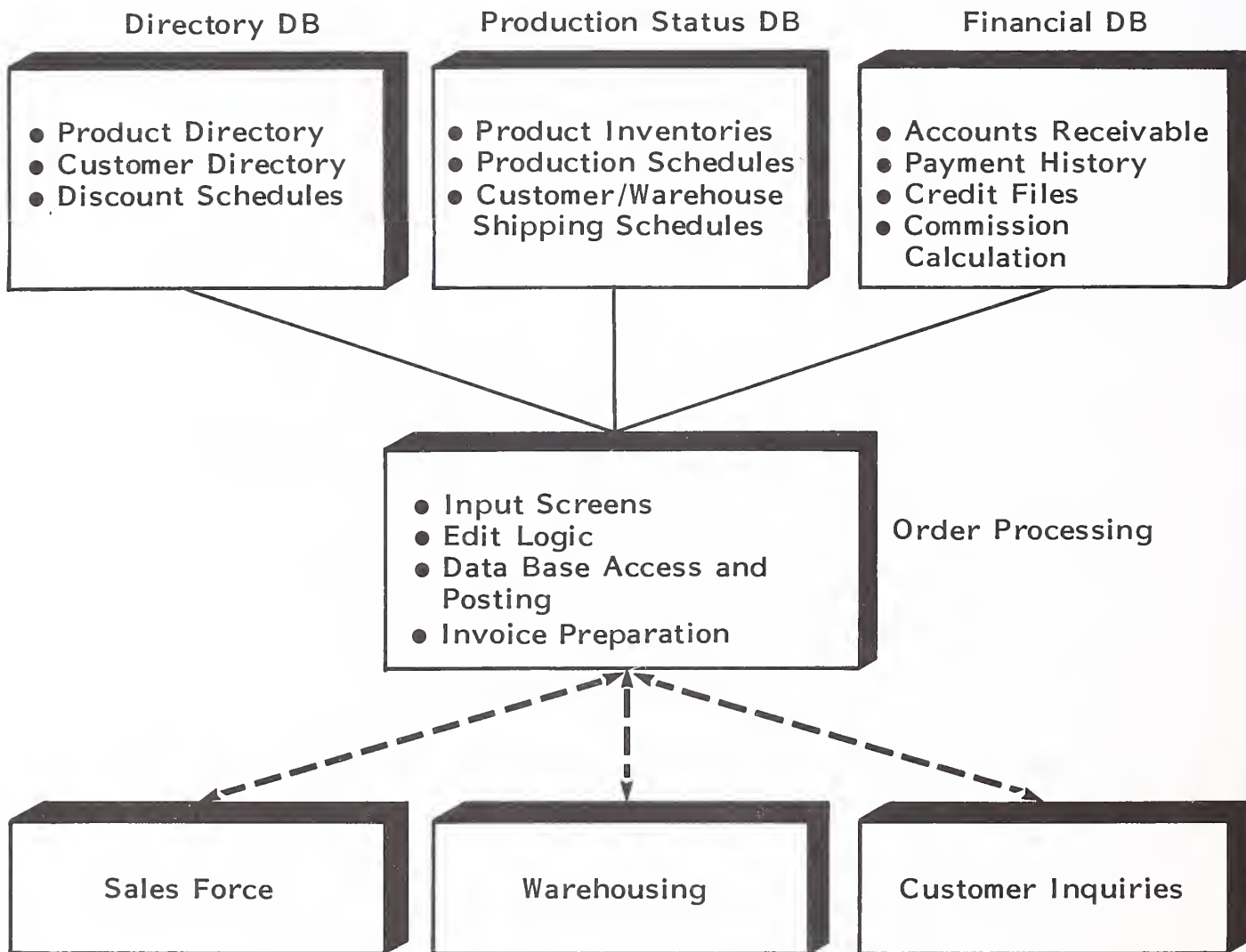
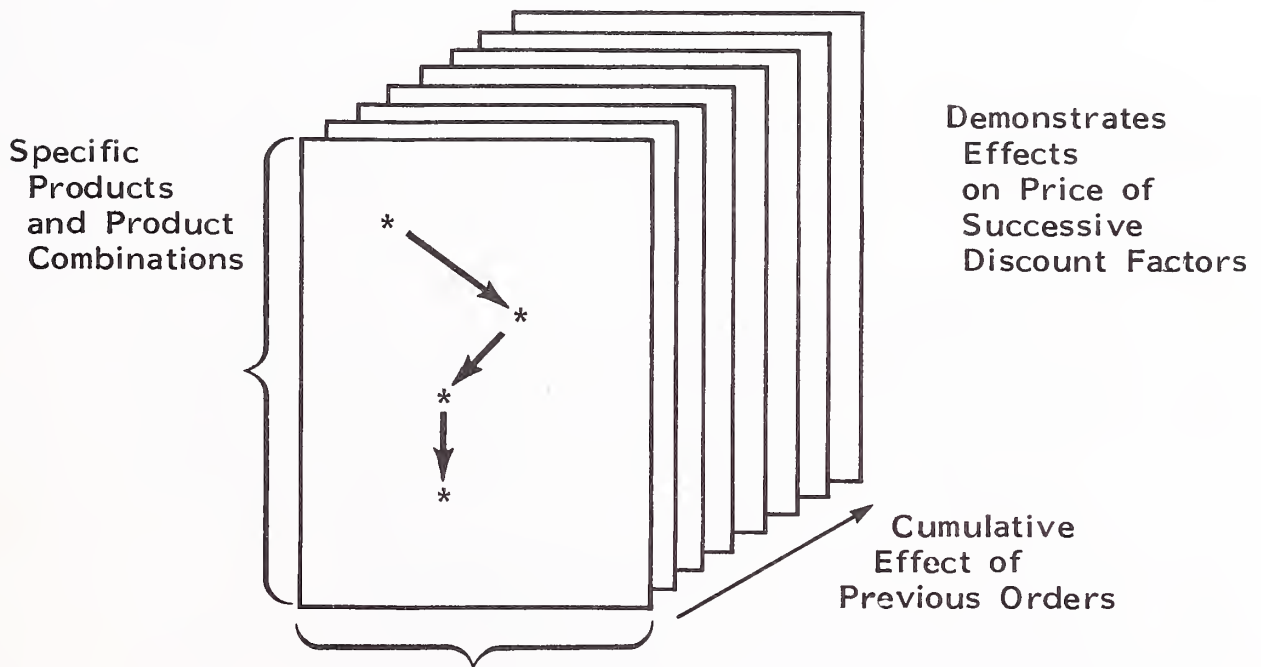

EXHIBIT III-4

CURRENT DISCOUNT STRUCTURE (Logical View):
PRINCIPAL DISCOUNT FACTORS



Order Sizes (Sometimes Mix and Match)

* Demonstrates Effects on Price of Successive Discount Factors

EXHIBIT III-5

CURRENT DISCOUNT STRUCTURE (Logical View):
OTHER DISCOUNT FACTORS

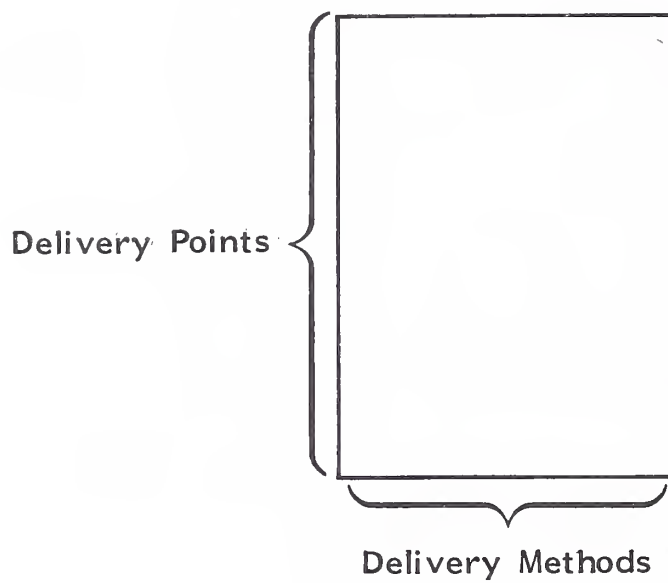

- Credit Factors
- Corporate Needs (Targets, Supply Costs)

- Because these systems are complex and cross many departmental boundaries, the order entry system does not have a departmental owner or champion. In fact, the only people who may fully understand the interrelationships of the various components are a few people on the IS staff (not including senior IS management). This has already had the following unfortunate consequences:
 - The complexity of the system causes it to sometimes produce unexpected results that, while not true errors, are still wrong in the eyes of users.
 - Even when the system is functioning perfectly well, users must be educated on how apparently unexpected results are perfectly valid (e.g., the workings of the discount schedule).
 - Because of these problems in user understanding, the IS staff is very cautious in accepting and implementing changes to the order entry system. This has produced enormous backlogs that have given both the order entry system and IS a very bad name among users.
 - IS is the good-faith defender of an adequately functioning system that produces significant corporate benefits. However, it receives no credit for this. Instead, IS is widely believed to be holding onto power by controlling this system.
- Thus it should not be surprising that when the first micros came on the scene in the early 1980s, many of the dispersed branch office users (supply points, sales offices, warehouses, etc.) saw the acquisition of an "order entry" PC as the solution to their problems in dealing with a quirky, difficult-to-use host system.
 - These usually fuzzy and technically deficient requests were rejected individually by IS. Unfortunately, IS did not use this as an opportunity to educate all users on how (and why) their system operated. Instead,

IS merely said that standalone PCs could not be fitted into an interactive environment.

- As different end users saw how they had been "defeated" on this issue, increased resentment toward the perceived IS technocrats built up.
- The end users have since become generally aware of the potential for M-M connections and have seen the potential for applying this to the order entry problem. The IBM 3270 PC has been an especially potent symbol for them (although the 3270 PC may not in fact be best suited to their needs). The dispersed end users have learned from their past mistakes:
 - They are approaching IS as a group so they cannot be "defeated" piecemeal.
 - They are adopting what is to them a very plausible rationale:
 - The 3270 PCs are not meant to replace the main system but to supplement it, especially during peak periods.
 - The local systems can deal more responsively with local customers and will, in fact, often have a better knowledge of local supply and inventory conditions than the centralized system will show.
 - The local systems will faithfully produce transactions to feed the central systems so that no corporate information is lost.
 - Because of bad feelings that have long existed and are increasing, this issue has become for the users as much an emotional and political issue as a business and systems problem.

- IS still does not see the order entry system as a central system extending its nerve endings throughout the corporation. IS management takes "order entry" at its face value and sees it more or less as the property of the branch locations that are agitating for change.
 - The best response would be to fight fire with fire and mobilize the other heavy-hitter groups (e.g., marketing, manufacturing, finance) that interface with the system to protect their interests.
 - Being politically naive and technically oriented, IS instead has suggested a systems study to see how an M-M link could be accommodated.
 - This has only further infuriated the branch users, especially since they now believe that IS's anti-standalone-PC arguments were not made in good faith but were just excuses to save the "IS empire."

- The branch users have formulated difficult-to-deny requests for local customer lists and records, product volume and mix discounts, and transaction formats.
 - They have a very simplified view of how the order entry system works from their standpoint, as shown in Exhibit III-6.
 - Either they are oblivious to the interplay between order entry and financial and manufacturing systems or they argue that their local information is better anyway.
 - Because the centralized discount calculation has in fact worked well, they are often not aware of the complex and subtle factors that can routinely influence discounts. (Or when they are aware, they often would not wish to be constrained by central discount rules anyway.)

EXHIBIT III-6

DISTRIBUTED USER VIEW OF ORDER ENTRY APPLICATION

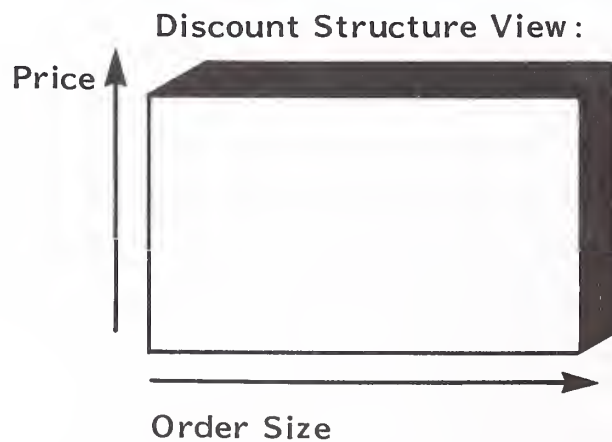
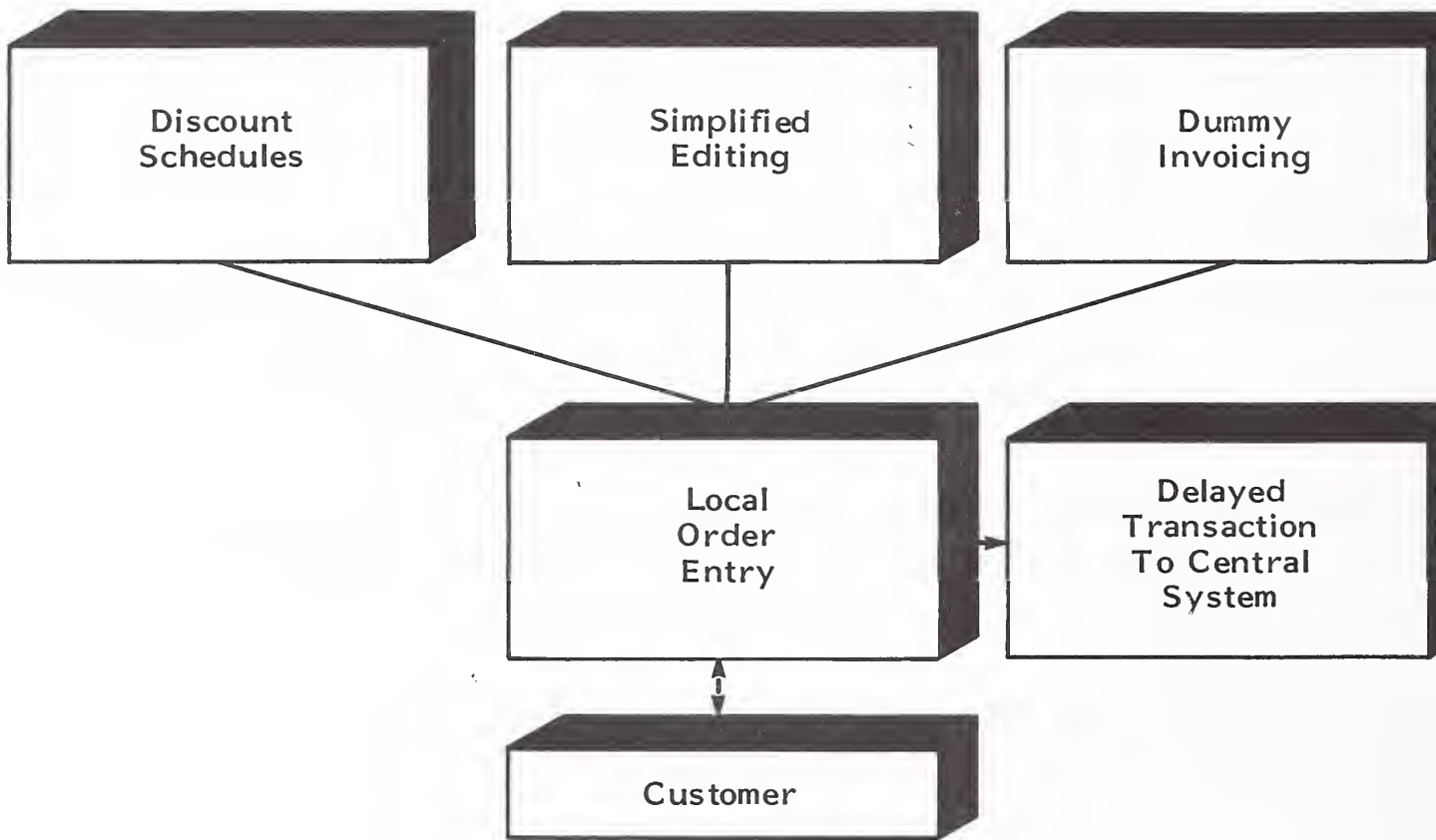

- In these two companies it is almost certain that multiple deviant local systems will be developed with little or no IS control or coordination.
 - These deviant local systems are bound to corrupt the data that is going into the central system, which will increasingly be treated as a pro forma afterthought by the branch users.
 - This, in turn, will shake the confidence of the headquarters users (finance, manufacturing, etc.), and they too may turn on IS and the central system with incalculable consequences.

- Conclusions: Win-win situations should always be a systems goal. Unfortunately, this has turned into a lose-lose situation.
 - There is a gulf of ignorance between the end users and IS management.
 - The end users do not appreciate technical issues and problems.
 - Top IS managers have raised the drawbridge around their technical world.
 - While IS is probably correct to say that a difficult technical problem needs more study, this is an answer that end users have heard too often.
 - An organizational change is probably the only solution to this problem. That is, IS top management (at a minimum) would change, and data processing functional responsibilities would possibly be restructured.

E. THE UNIX TIME BOMB

- A major energy firm has upgraded its information center services to provide downloaded data for use on IBM PCs, as shown in Exhibit III-7.
 - In-house modification to an ASCII communications package enables host summary file data to be transmitted to PCs in VisiCalc-compatible form, as shown on line (a) of the exhibit.
 - The service has worked well, even though downloading is handicapped by the low speed and unreliability inherent in asynchronous communications.
 - The success of using PCs has whetted user appetites for more. However, users have had differing ideas on what "more" consists of.
 - Some want much more data than current methods allow; they also want to be able to perform much more complex analyses.
 - Others want to share data between users, either on the same machine or on different machines.
 - Still others want to take over analytic and, perhaps, operational tasks now performed on the host system.
 - Although they are knowledgeable about their own functions, the users are not very informed on data processing issues. They believe, however, that the capabilities represented by the PC/XT or similar machine will give them the upgrade needed.
- Some IS staff members (with no discouragement from IS management) have led users to believe that UNIX is the answer. UNIX is:

EXHIBIT III-7

AN UNPLANNED EVOLUTION INTO A UNIX ENVIRONMENT

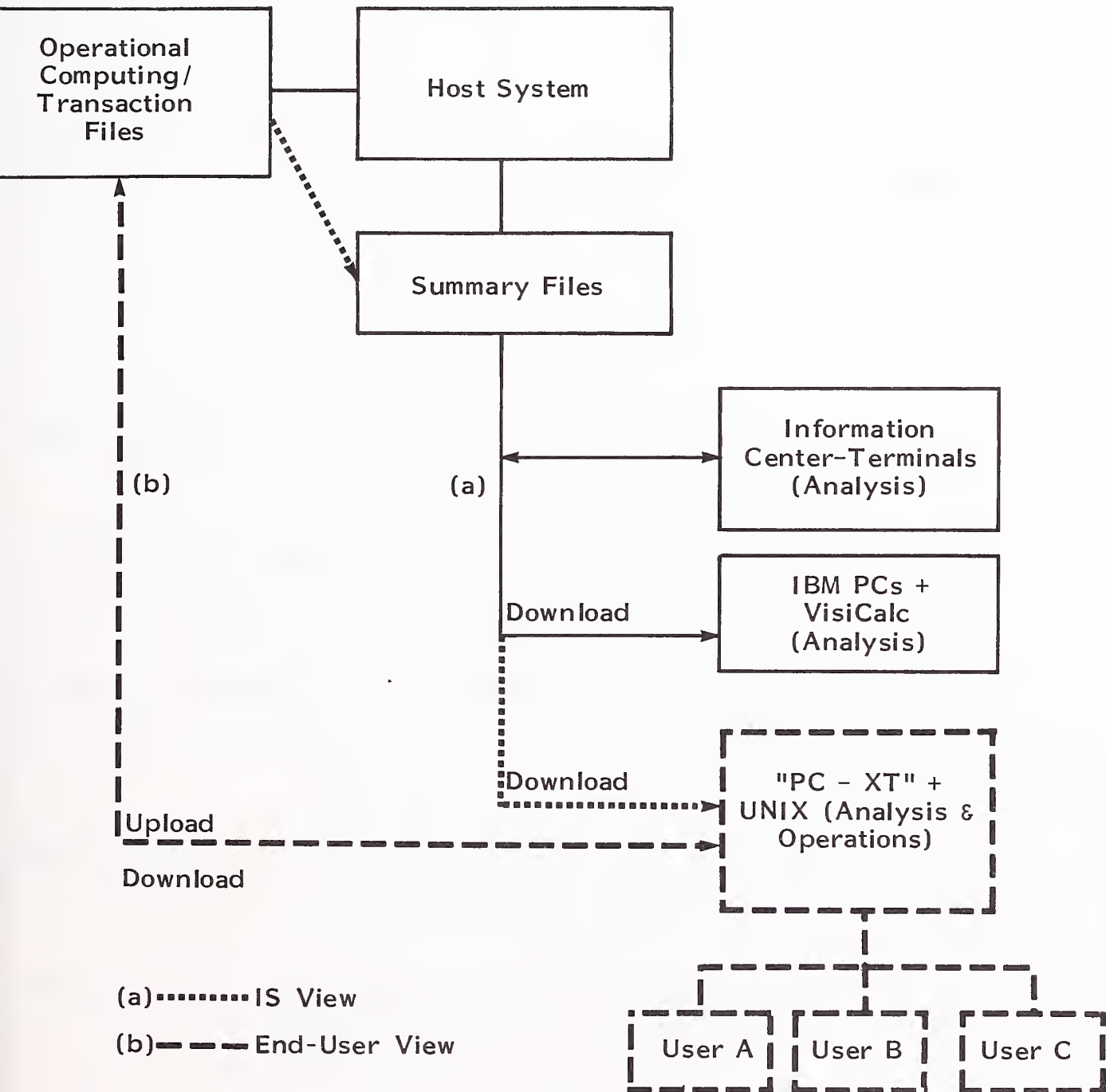

- Very powerful and flexible.
 - Able to provide function-specific "shells" to users.
 - Multiuser and multitasking.
 - Most suited for the more powerful micros, both current models and those on the horizon.
- This message has met a receptive audience. Many of the users have heard enough about UNIX to be predisposed in its favor. They are now pushing IS to:
 - Install UNIX software.
 - Implement UNIX-based micro systems.
 - Modify host systems to take account of these new locally based capabilities.
- IS management is willing to provide several UNIX experts (on a relatively junior staff level) to help users make changes on a local basis. But IS management is totally unwilling to make a central IS commitment to a UNIX-type solution. The IS interest in UNIX is only one of a number of esoteric or experimental approaches that have gained moderate amounts of resources and backing within IS.
 - Although IS has spoken of decentralization and user-oriented development, what IS management means by this is:
 - User department funding of development and maintenance activities that are still centrally managed.

- User involvement in specific applications, including user direction of system development projects.
 - An IS organization that is applications system oriented.
- IS itself is still centrally controlled and, equally important, still believes in massive host-based systems. IS's major financial commitment is still to traditional IMS-based systems. Its design philosophy still revolves around the traditional IMS-based systems as well.
- More tellingly, IS's senior technical staff identifies very closely with large-scale IBM operating systems, DBMSs, and communications systems. These people are highly skilled (and highly paid), and some are worried that their marketplace worth may decrease if UNIX (or other M-M approaches) begins to change the rules and practice of system building.
- Senior IS management is less emotionally committed to centralized solutions than is the senior technical staff. However, senior management is technically obsolescent, and managers are not willing to make decisions that go against their senior technical staff in areas perceived to be largely technical.
- Consequently, IS management has temporized on the UNIX issue. They did not discourage the UNIX missionaries, because:
 - The IS department has had a long tradition of being technically innovative.
 - "UNIX" is a powerful if not a very well understood word.
 - This corporation's users, like those of most user departments, have become restive as a result of backlogs, inflexible systems, etc.

- IS management sincerely wants to put more capabilities into the hands of users.
- IS management does not fully understand the self-interest that is largely motivating its senior technical staff's opposition to UNIX. Consequently, IS management has fallen into the position of agreeing to UNIX use on a very limited basis; i.e., there will be:
 - No central IS-provided training or support.
 - No senior staff involvement.
 - No dislodgement or modification to current or planned host-based systems.
- Neither IS management nor the user departments are yet conscious of the magnitude of their problem; they are on a collision course.
 - IS believes that UNIX is only an upgrade to VisiCalc, as shown on line (a) of Exhibit III-7. In IS's view, nothing essential should or can change in the technical or power relationships.
 - Key users, on the other hand, see UNIX-based systems as the beginning of independence from what are (in their view) torpid, ineffectual centralized systems, as shown on line (b) of the exhibit.
- Users do not understand the reasons for IS management's and its senior technical staff's almost casual involvement in these technical issues.
 - Users have also tacitly assumed, but in a totally different way, that UNIX is only an upgrade to VisiCalc.

- They believe that off-loaded host functions can be taken over as easily by using UNIX as downloaded data could be handled using VisiCalc. This is, of course, totally untrue but will become apparent to users only after a considerable expenditure of money and time.
- Note: For additional analysis of the UNIX issue, see Section A of Chapter V.
- Conclusions: Technical enthusiasts can often lead the uninitiated astray.
 - More tellingly, IS management has not adopted a well-thought-out position on what is a difficult and potentially disruptive issue.
 - Although no disaster will occur, there will be much wasted time and effort. IS will lose face in the estimation of its users.

F. AN INSURER'S MICRO-MAINFRAME NONCONNECTION

- A leading property/casualty insurance company decided several years ago to convert from a relatively primitive in-house system to a leading vendor's package. The IS department was the major proponent of the vendor selected.
 - Unfortunately, the initial stages of installation were not smooth, and key users became quite concerned about:
 - The length of time full installation would take (several years).
 - The expense.
 - The changes users would have to make to conform to the package (rather than vice versa).
 - The apparent inflexibility of the system, once installed.

- In the meantime, the users had learned of a new vendor's micro-based software that appeared to them to have significant advantages, including:
 - . Installation by independent line-of-business module (e.g., automobile, business owners, etc.).
 - . High tailorability.
 - . Quick installation.
 - . Lower cost.
- The IS department was unwilling to examine this new alternative in view of the fact that much company time and money had been spent in reaching what, after all, was a contractual commitment with the first vendor.
 - However, the users became increasingly convinced of the correctness of their position and elevated the question to CEO level.
 - The IS vice president refused to have anything to do with such a "wild" scheme, and when the dust had settled, one of the operational vice presidents had assumed authority for implementing the micro-based system in a number of business areas.
 - . The mainframe-based package was cancelled for the commercial insurance part of the business.
 - . IS was to play little role in the implementation.
- The stage was set for disaster.
 - However, the disaster did not occur.

- The installation of the micro system has been a success, meeting almost all user expectations (many more expectations than most similar mainframe implementations meet).
- The success was due to a combination of the vendor's product and, especially, user commitment and involvement.
 - One of the features that the users found especially attractive about this product was that knowledgeable user personnel could interact directly with the software during system construction.
 - This interaction had a significant impact on speed, accuracy, and acceptance.
- In a way, the project has been too successful. The line-of-business managers are running what are, in essence, miniature data processing departments.
 - Data to support the traditional host-based accounting and statistical systems is rekeyed from micro output into the host system, as shown in Exhibit III-8.
 - This is an ironic mirror image of many current micro downloading practices.
- What is finally beginning to be discussed within the company is a means by which a new host data base could be constructed to collect data of corporate interest now being generated by the micros.
- Conclusions: The somewhat surprising success of this end-user initiative was due to deep commitment, good project leadership, and a good product foundation.

EXHIBIT III-8

AN INSURANCE COMPANY'S MICRO-MAINFRAME NONCONNECTION

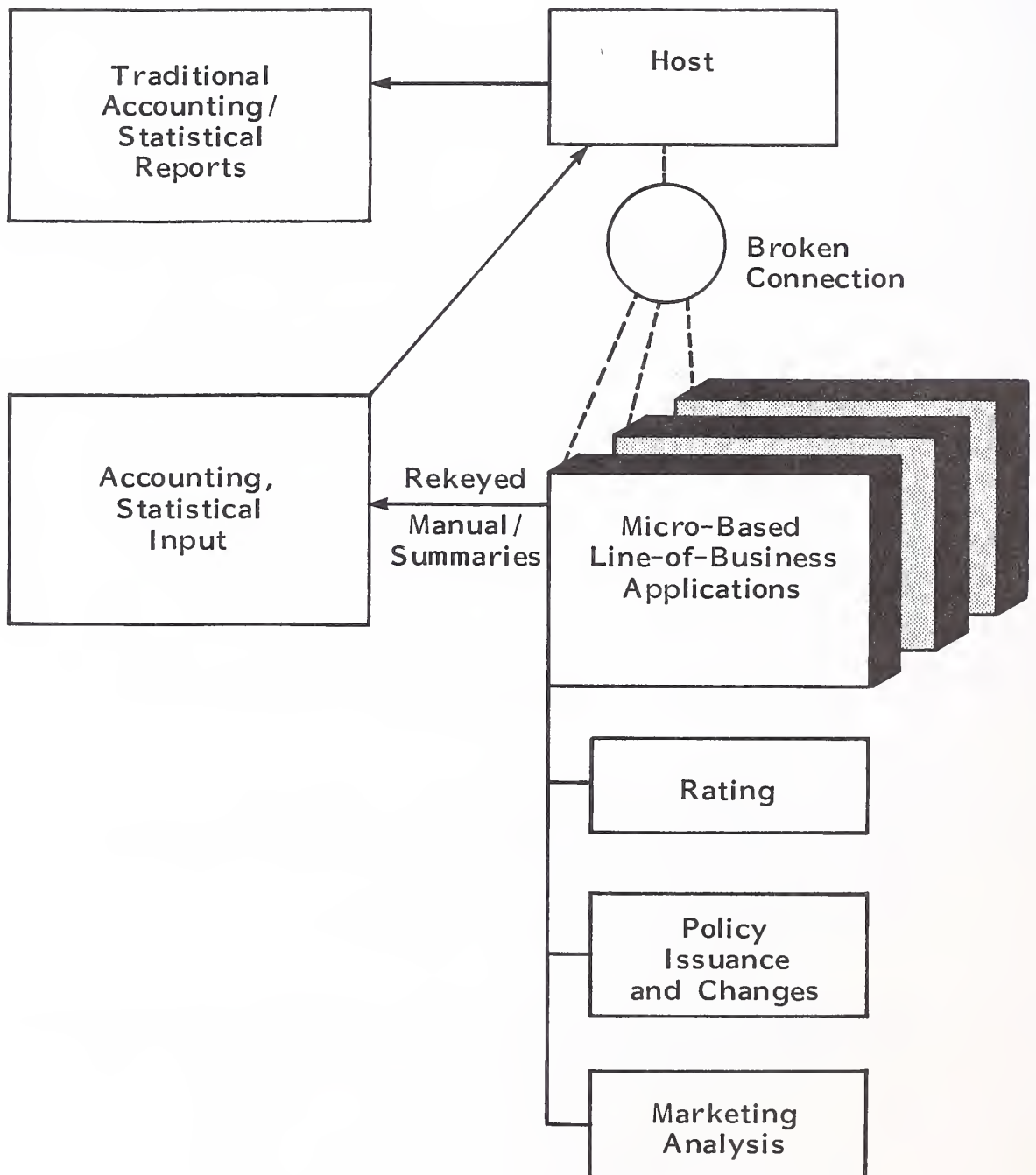

- Unless the micro IS kingdoms are reintegrated, the inevitable problems of inconsistency and incompatibility will arise. This is doubly true since success was due partly to a fortunate combination of personalities.
- There will be problems, in the after-the-fact integration of subsets of locally generated data into a corporate data base.

G. SUMMARY

- These six companies show a great diversity in their M-M initiatives and the manner in which the initiatives arose, as shown in Exhibit III-9.
- One common thread is that success is highly dependent on the technical adequacy of the plan.
 - The two organizations with high success probabilities are both using proven technology. (The bank is using an evolutionary version of an earlier system; the insurance company is using a vendor's package.)
 - However, user understanding and commitment is necessary, too, for the "micro" part of micro-mainframe to work well.
- It is also noteworthy that in four of the six companies the initiative came from users.
 - This was not surprising in view of the relatively low quality of relationships between IS and these users.
 - Users are taking these kinds of initiatives now in part because they are making an imperfect analogy:

EXHIBIT III-9

END-USER CASE STUDY SUMMARY

Case Study	User Satisfaction with IS	Micro Initiative from		Political/Emotional Content	Technical Adequacy of Initiative	End-User		Probability of Initiative's Success	
		User	IS			Technical Understanding	Commitment	Current	Future
Bank	High		X	Low	High	Medium	Medium	High	High
Retail	Low / Medium	X		Low	Medium	Low / Medium	High	Medium	Low
Order Entry (2)	Low	X		High	Low	Low	Medium	Low	Low
UNIX	Medium		X	Low	Medium	Low	Medium	Low / Medium	Low
Insurer	Low	X		High	High	High	High	High	Medium / High

- . Micros have proven easy, effective, and inexpensive to perform analytical work (indeed, better in these respects than host systems, in the eyes of many users).
- . Therefore, the same kind of benefits accrue when switching from analytical to operational uses. However, these uses are quite different, as shown in Exhibit III-10.
- It should be emphasized that these users were not concerning themselves with trivial issues; the micro-based systems they want are central to their operations.
 - In a way, these ambitious goals are a compliment to data processing and, perhaps even more so, to the mystique of the micro.
 - It also symbolizes user frustration with conventional data processing, as the users see it. There is, unfortunately, little that IS can do to relieve these frustrations, at least in the short run.
- In organizations where IS-user relationships are not good, these user initiatives will grow more common, at least for a few years, until the news of the high casualty rates filters back from the front lines of M-M implementations.

EXHIBIT III-10

DIFFERENCES BETWEEN ANALYTIC AND PRODUCTION SYSTEMS

FACTOR	ANALYTIC	PRODUCTION
Senior Personnel Initiate?	Yes	Not Usually
Senior Personnel Use?	Yes	No
Timeframe	Short	Medium to Long
Changes in Software Design/ Coding Assumed?	Yes	No
System Reused Regularly?	Sometimes	Usually
Model Oriented?	Yes	No
Off-the-Shelf Packages Usable?	Rarely	Usually
New Internal Data Elements Created?	Rarely	Often
External Data Required?	Often	Rarely

IV MICRO-MAINFRAME FUTURE DIRECTIONS

IV MICRO-MAINFRAME FUTURE DIRECTIONS

A. SHARED FUNCTIONALITY

- INPUT has coined the term "shared functionality" to describe one of the key characteristics of future M-M applications.
- The concept of shared functionality is straightforward; it is the sharing of processing and data between mainframe and micro, as shown in Exhibit IV-1. It is allied but distinct from older views of distributed data processing (DDP). DDP is different in that:
 - It was usually seen as being controlled from a central point, while shared functionality is based more on equality.
 - A major motivating force was IS efficiency, rather than meeting end-user needs.
 - Perhaps more importantly, DDP has always been more of a theoretical than an implementable approach.
- What is somewhat surprising is that fully 85% of the corporate respondents to the INPUT survey subscribe to this M-M view. (This percentage would be far more surprising if not for the circumstances described in Section B of Chapter 1.)

EXHIBIT IV-1

RESPONDENTS' VIEW OF SHARED FUNCTIONALITY

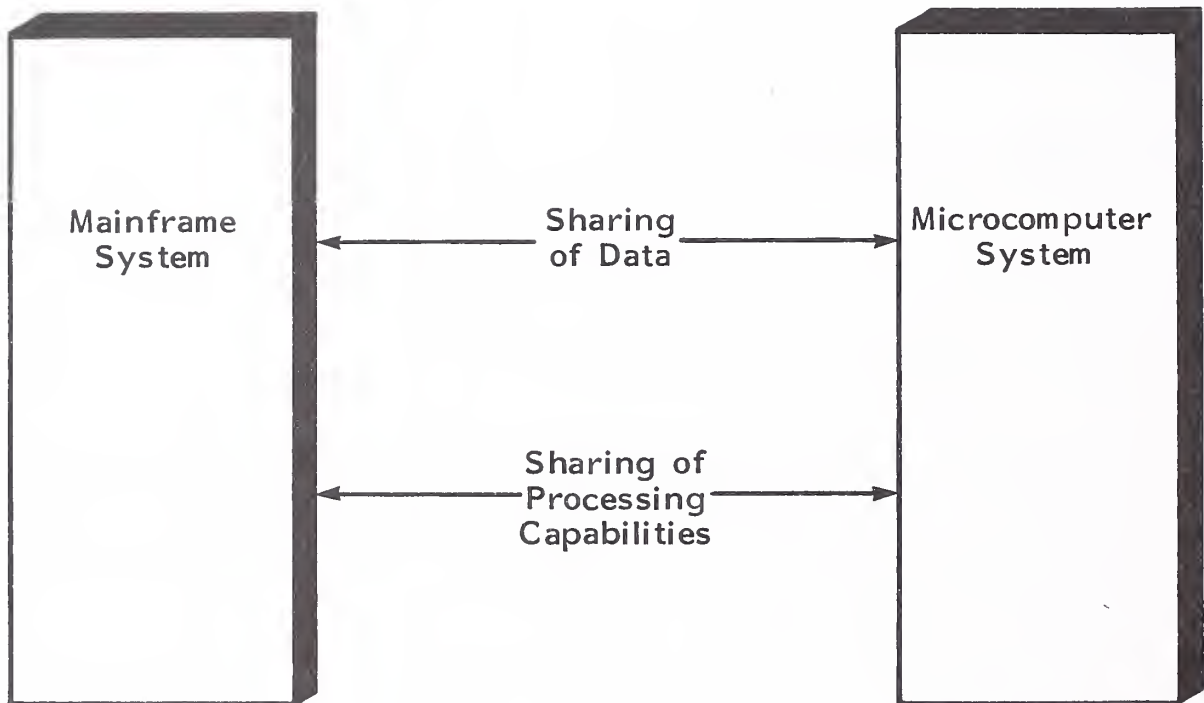

- 85% of respondents subscribe to this view of micro-mainframe applications.

- The case studies in Chapter III bear out this attitude on the part of users.
- Needless to say, this kind of M-M system does not exist in most companies today. In addition, based on INPUT's experience, many key people in IS organizations have not yet accepted this view. Rather, their view would be more like that in Exhibit IV-2, where suitably protected data flows from mainframes to micros. Meaningful (i.e., nonanalytic) production processing is confined to mainframe systems.
- Of course, this high level of agreement (agreement that shared functionality is the chief characteristic of M-M applications) could only have indicated agreement with broad principles. Consequently, respondents were asked if they felt "most applications that are now host-based will (in three to five years) have a considerable amount of functionality taken over by personal computers linked to the host."
 - Naturally, there was far more diversity here. However, three-quarters of respondents see host applications having these shared functionality characteristics within five years, as shown in Exhibit IV-3. About a quarter of all respondents were very positive in their support of this position; many were already, in fact, implementing M-M applications.
 - This is consistent with the fact that virtually all respondents were able to give several examples of M-M applications implemented or in the process of being implemented. Although most of these applications were rather primitive, they were nontrivial.
- The average score supporting shared functionality (on a scale of +5 to -5) was +1.7. The most favorable group had a score of +4.5, and the negative/neutral group scored only -2.2.

EXHIBIT IV-2

KEY I.S. MANAGERS' VIEW OF SHARED FUNCTIONALITY

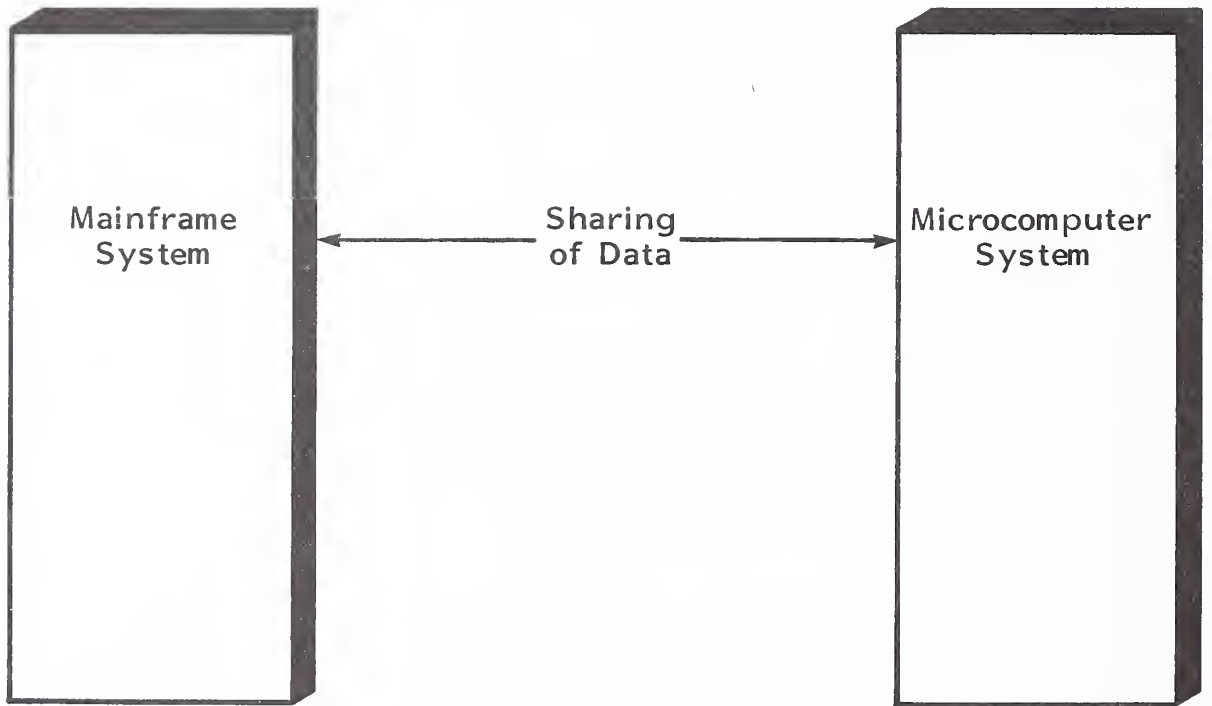
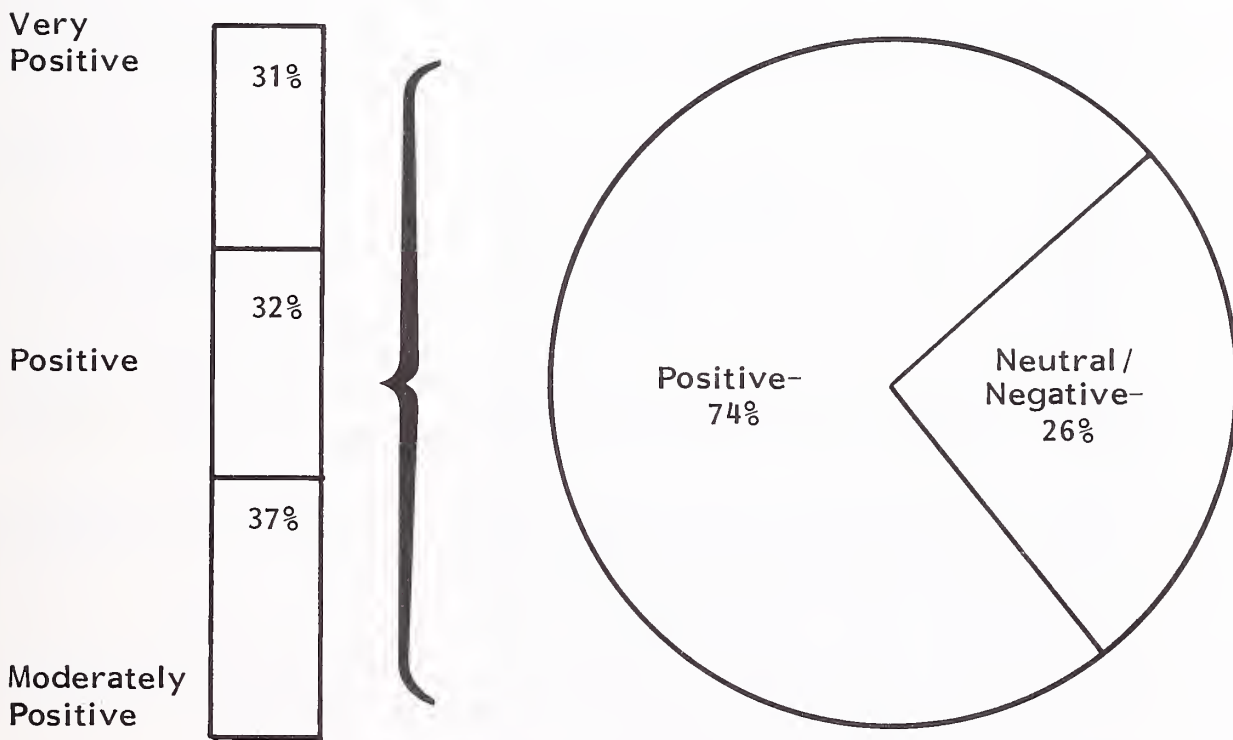

EXHIBIT IV-3

EXPECTATION OF EXTENSIVE
HOST-MICRO SHARED FUNCTIONALITY APPLICATION



- Generally speaking, the more positive attitudes toward shared functionality, as shown by Exhibit IV-4, were held by activist-type organizations. These organizations:
 - Planned to use outside sources of assistance.
 - Were more aware of potential problems.
 - Saw more complex uses of M-M links.
- Those organizations less positive toward shared functionality tend to be more passive in their plans for M-M connectivity, as shown in Exhibit IV-5.

B. TYPES OF MICRO-MAINFRAME LINKAGES

- Conceptually, M-M connectivity ranges from the manual entry of previously unautomated data to interactive, segmented programs.
 - Most current linkages are products relatively low in the connectivity "hierarchy," as shown in Exhibit IV-6.
 - However, the goal of shared functionality implies reaching the "4" or "5" level shown on the exhibit.
- This was confirmed by asking corporate IS respondents whether they saw M-M links as being:
 - Predominantly interactive.
 - Predominantly on-line batch (i.e., where the micro performs processing on a standalone basis and the micro and host periodically exchange data).
 - Equally interactive and on-line batch.

EXHIBIT IV-4

ATTITUDES TOWARD SHARED FUNCTIONALITY APPLICATIONS:
SELECTED GROUPS WITH HIGHER THAN AVERAGE ATTITUDES

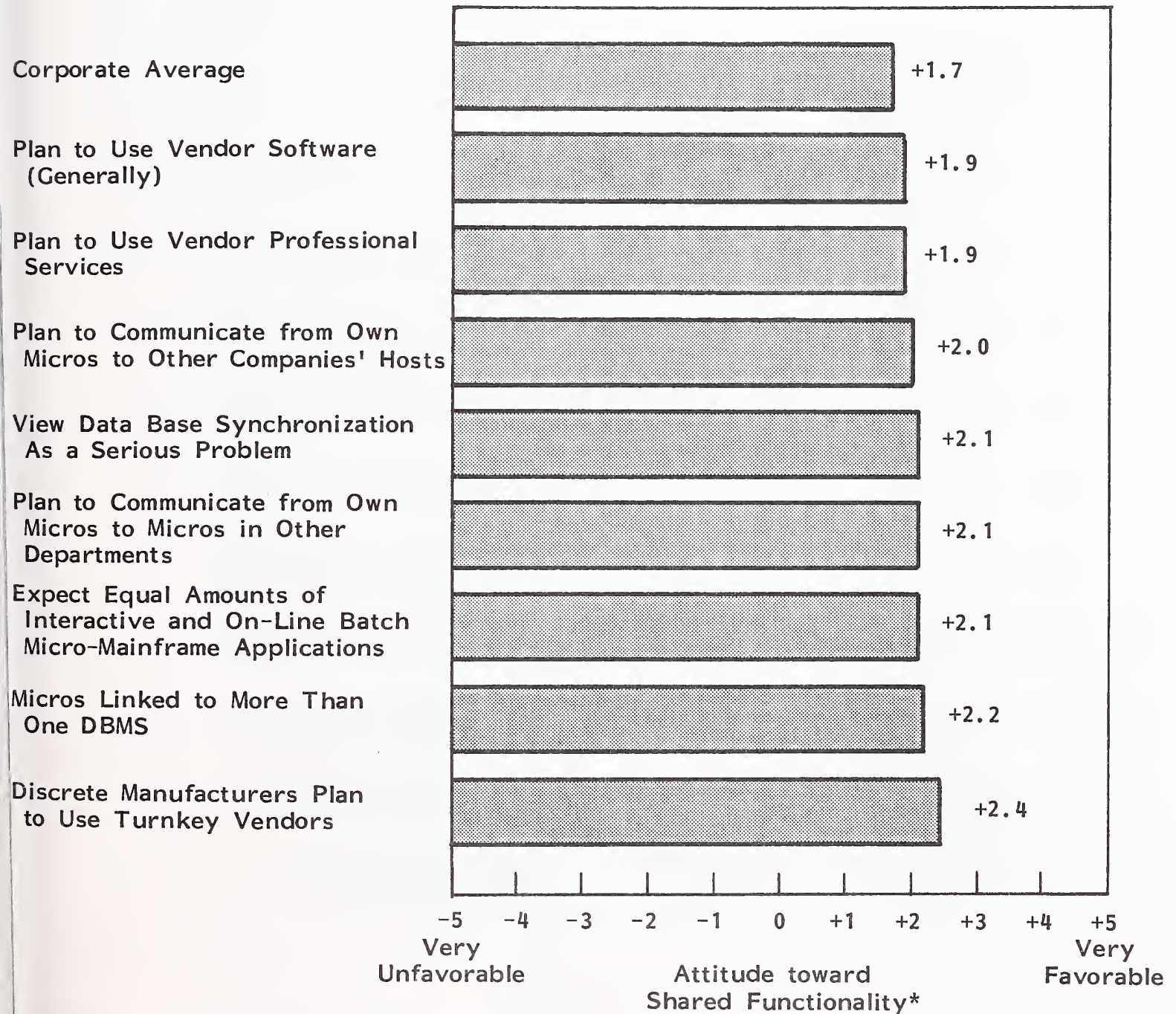

* Based on Rating Scale

EXHIBIT IV-5

ATTITUDES TOWARD SHARED FUNCTIONALITY APPLICATIONS:
SELECTED GROUPS WITH LOWER THAN AVERAGE ATTITUDES

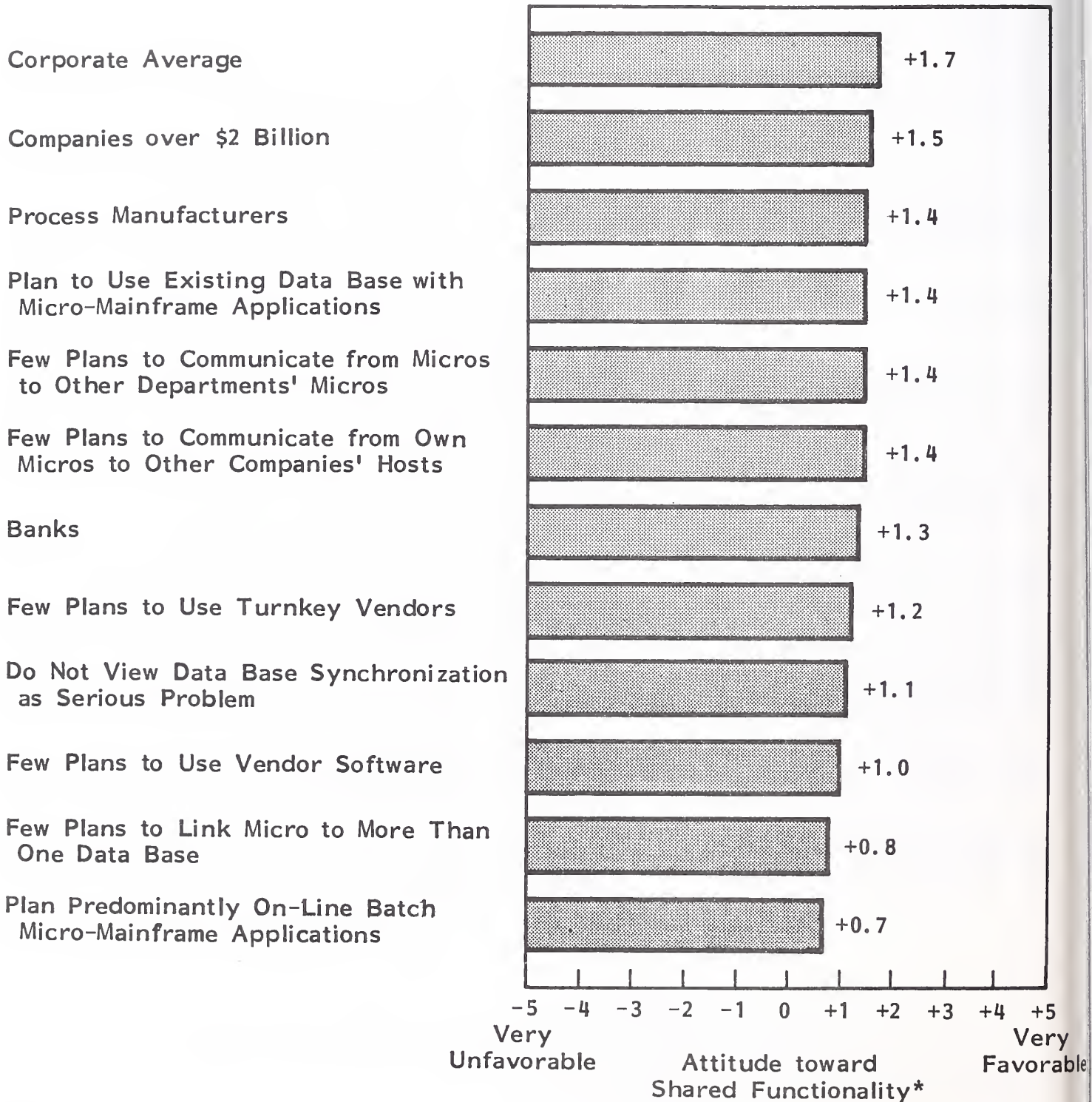

* Based on Rating Scale

EXHIBIT IV-6

HIERARCHY OF MICRO-MAINFRAME CONNECTIVITY

1. Manual
 - a. New Data
 - b. Rekeyed Data
2. Downloading - Low Speed
 - a. Extracts
 - b. Operational Files
3. File Exchanges (Bidirectional)
 - a. Low Speed, Proprietary Structure
 - b. Low Speed, Generalized Structure
 - c. High Speed, Proprietary Structure
 - d. High Speed, Generalized Structure
4. Logical Data Bases Covering
 - a. Multiple Physical Hardware Environments
 - b. Multiple Software Environments
5. Segmented Applications Programs
(Coordinated Processing Between Mainframe and Micro)
 - a. Batch
 - b. Interactive

Key: Darker Shades Indicate More Complex Issues/Unresolved Implementations

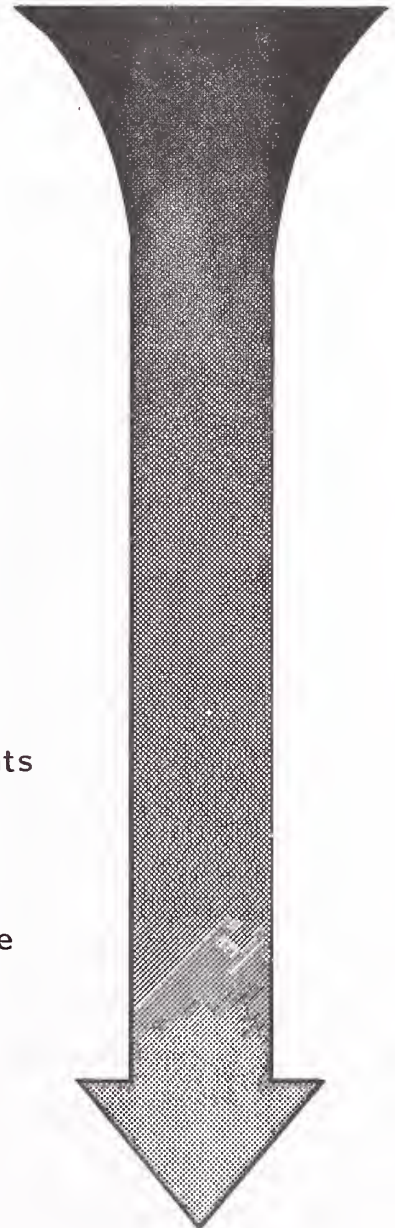

- Somewhat surprisingly, three-quarters of the corporate IS respondents see half or more of their future linkages as being at least partially interactive, as shown in Exhibit IV-7.
- This places the corporate respondents on the most demanding, leading edge of connectivity; that is, as shown in Exhibit IV-8, they require:
 - Interactive access.
 - On-demand file elements.
 - Generalized (as opposed to vendor proprietary) files.
- In contrast, vendor M-M links of a representative selection of leading vendors fall short in one or more areas, as shown in Exhibits IV-9 through IV-12.
- These vendor links are certainly only the first generation of such products. Candid vendors will admit that many (if not all) vendor links were rapidly put together to get products into the marketplace.
 - Because of their origins, the vendor products have little in common, from the standpoint of concept, design, or operation. These products are generally very proprietary in nature (i.e., they link to a specific vendor's product at one or both ends of the link).
 - As a class, these products should be viewed as stopgaps for vendors, IS departments, and users. They are certainly better than rekeying into spreadsheets but are in most cases probably not the foundation for long-term, key M-M systems.
- With this background, it is understandable that vendors were much more cautious than IS respondents were in judging the type of future M-M connectivity.

EXHIBIT IV-7

TYPES OF MICRO-MAINFRAME LINKAGES FORESEEN

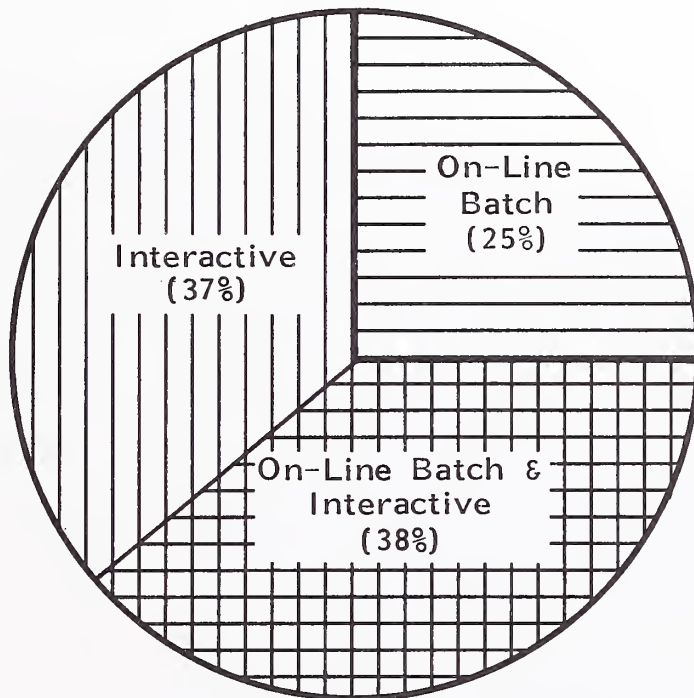

Percent of Linkage Types

EXHIBIT IV-8

MICRO-MAINFRAME LINKAGE ALTERNATIVES

TYPE OF QUERY

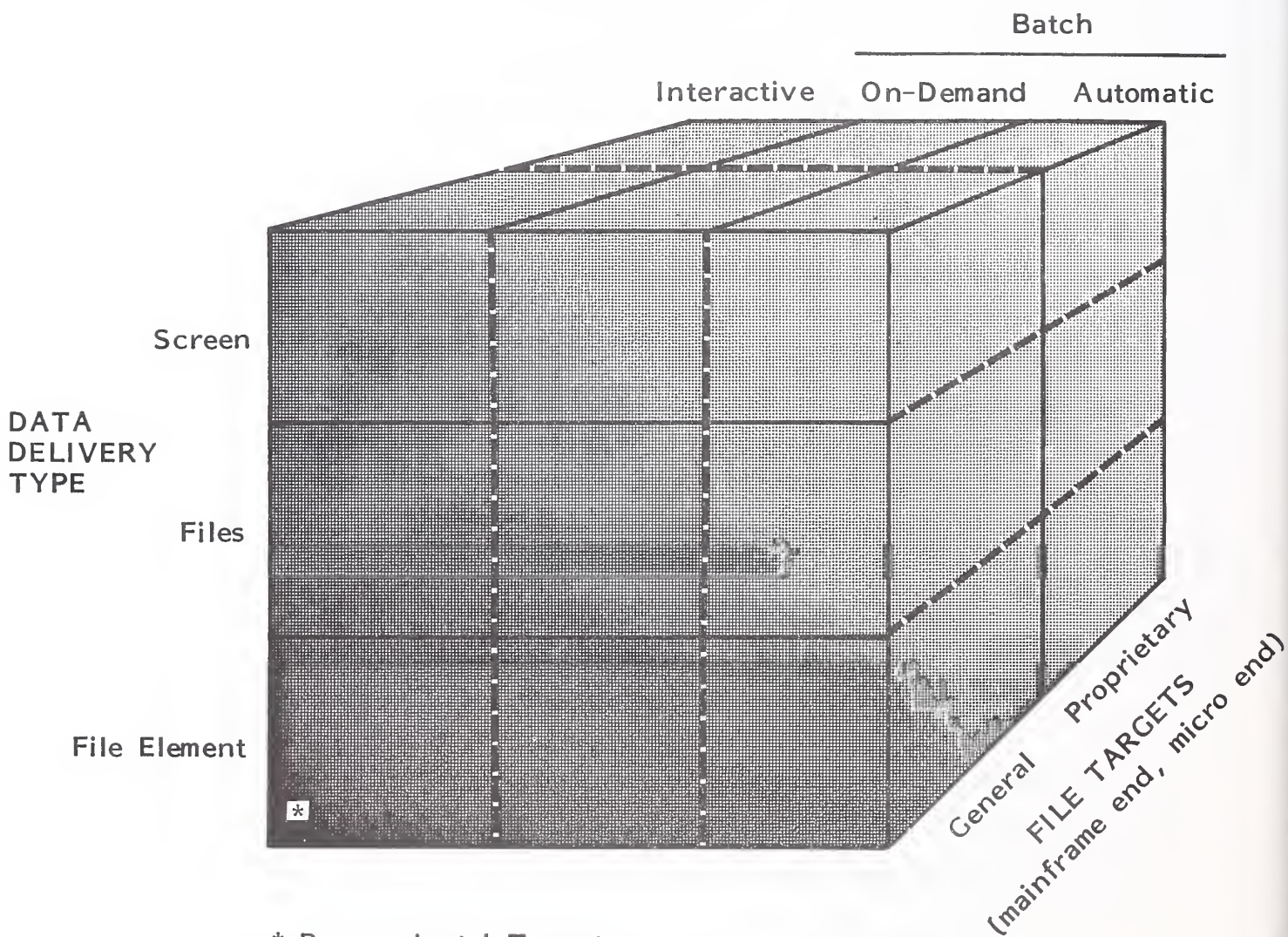

* Respondents' Target

EXHIBIT IV-9

CULLINET MICRO-MAINFRAME OFFERINGS
(Announced)

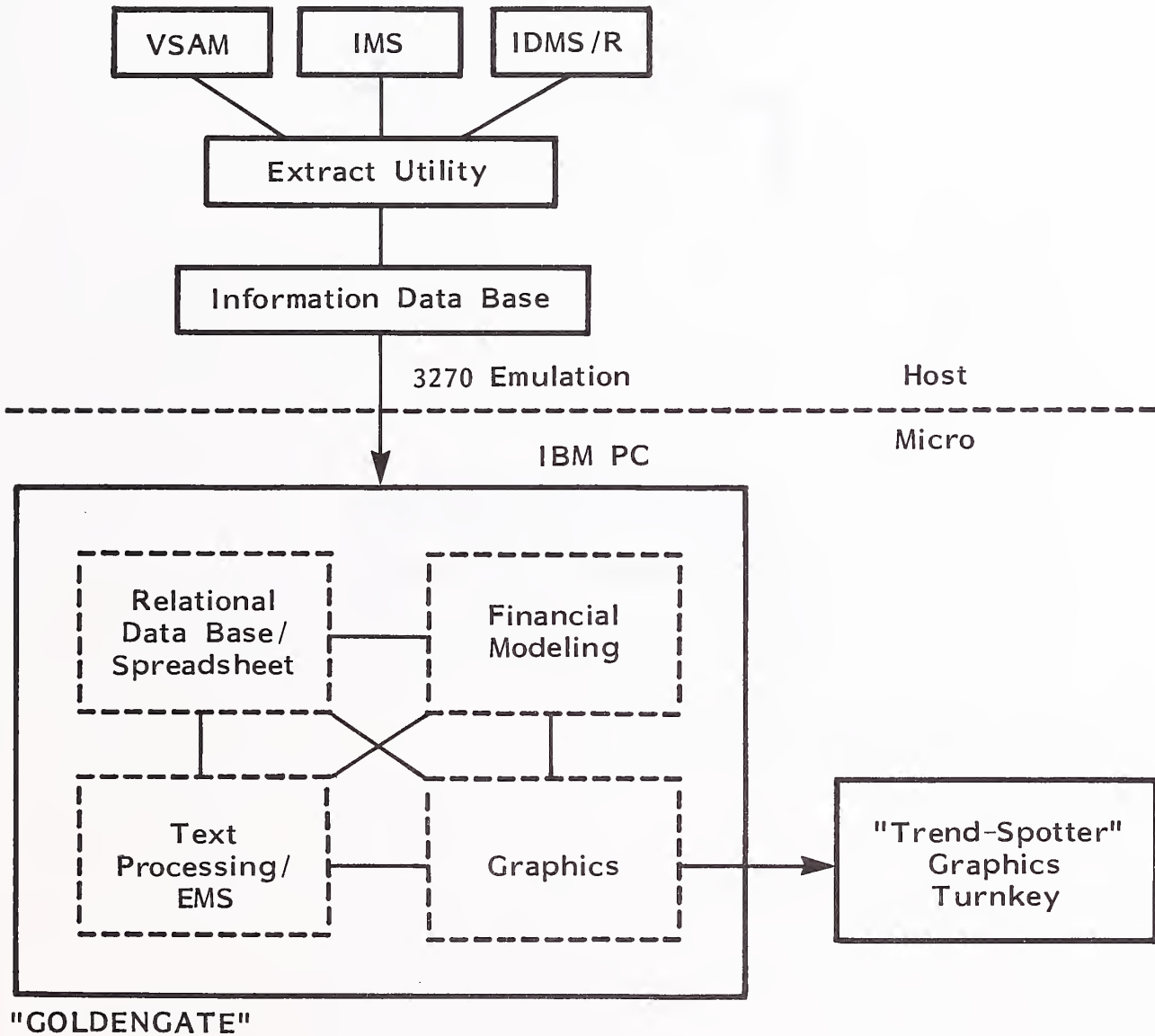
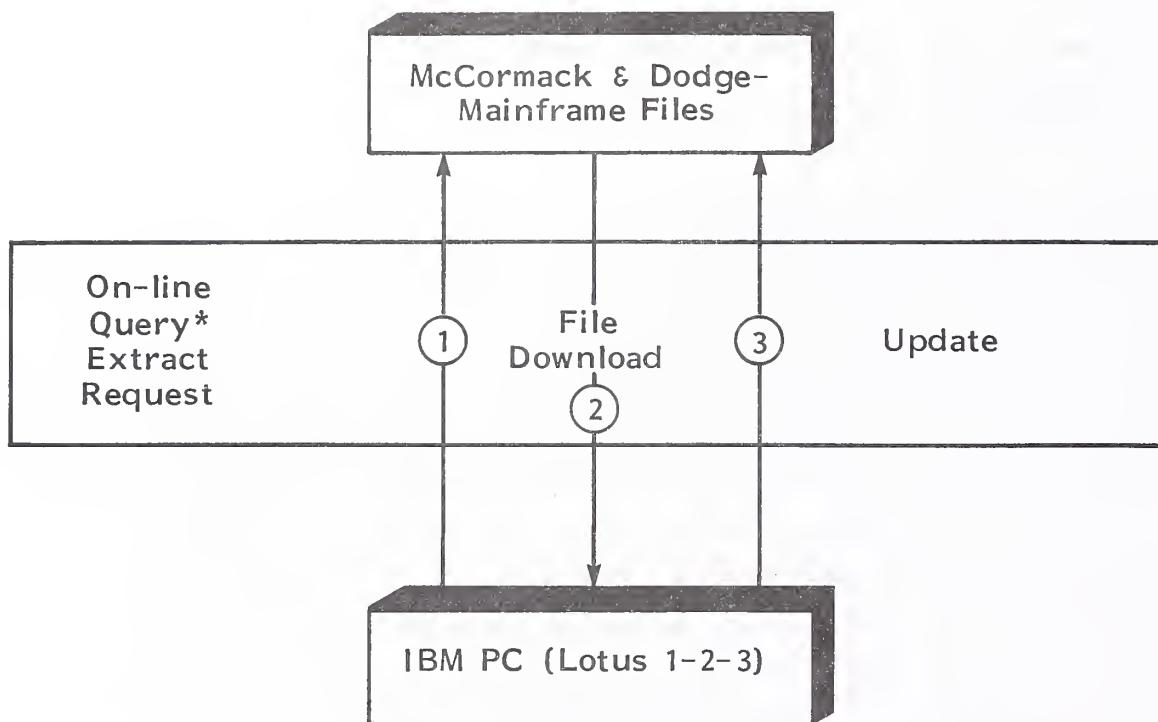

EXHIBIT IV-10

McCORMACK & DODGE MICRO-MAINFRAME OFFERING



* Non-McCormack & Dodge = Batch Mode

EXHIBIT IV-11

INFORMATICS MICRO-MAINFRAME OFFERING (VISIANSWER)

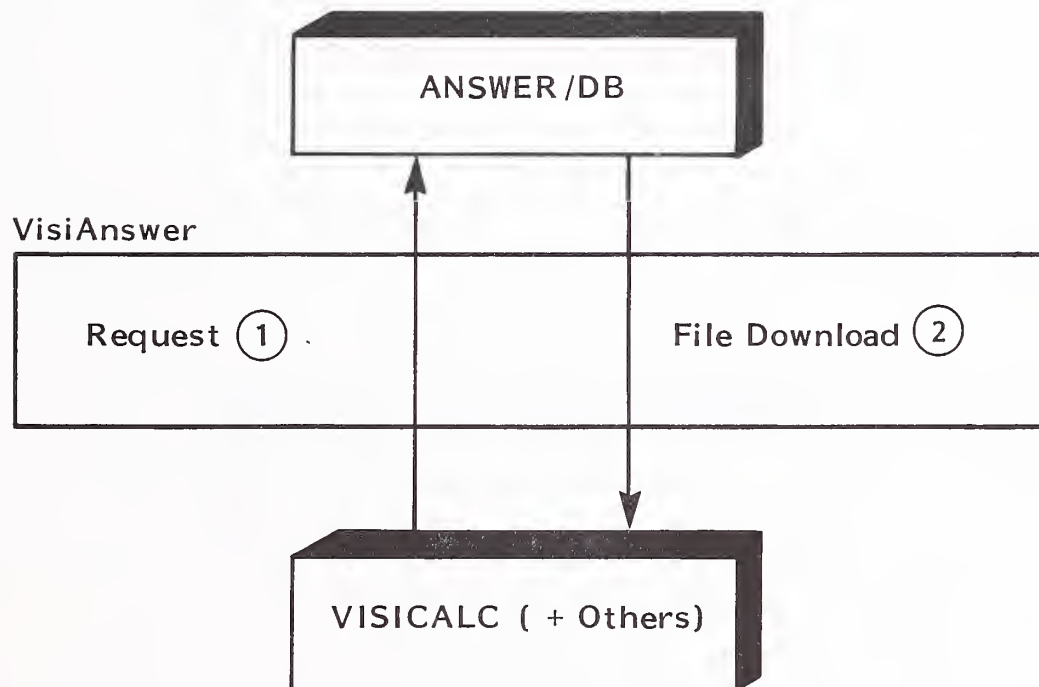
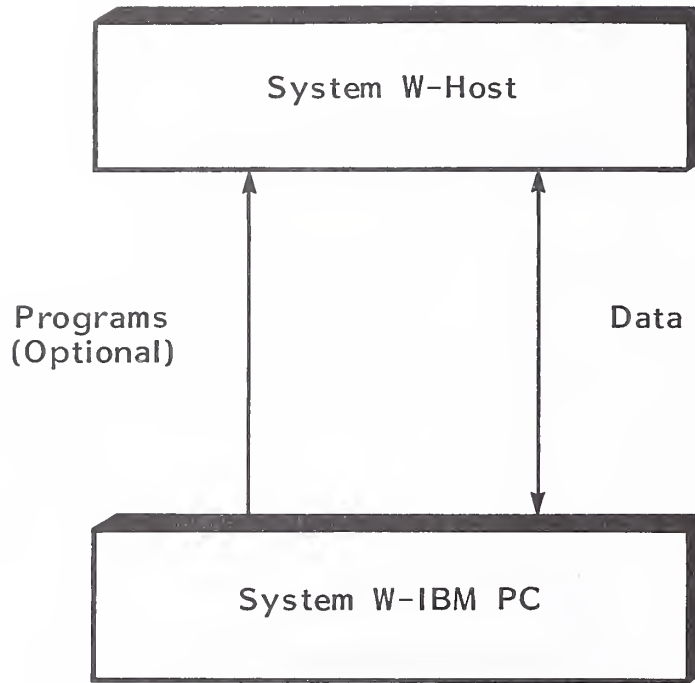

EXHIBIT IV-12

COMSHARE'S SYSTEM "W"



- Only half as many vendors as IS respondents saw interactive M-M applications predominating, as shown in Exhibit IV-13.
- Three-quarters of vendors see on-line batch applications playing a key role; this is a mirror image of what IS respondents see.
- For reasons that will be explored more thoroughly in the next chapter, INPUT believes that the vendor assessment is more realistic: the technology is largely here now for on-line batch applications, and this approach will always be easier to implement, with less risk.

C. DEVELOPMENT APPROACHES TO MICRO-MAINFRAME APPLICATIONS

- These are three basic strategies for developing M-M applications:
 - Modifying existing software.
 - Adding new application codes to an existing data base.
 - Writing entirely new applications.
- IS respondents were somewhat more in favor of the modification strategy than vendors were, as shown in Exhibit IV-14.
 - Interestingly, vendors were somewhat more balanced in their appraisals and tended--more than IS staff did--to see new applications as necessary.
 - The vendors were undoubtedly affected by hopes that existing software or DBMS could be used (when the vendor respondents offered one).

EXHIBIT IV-13

INTERACTIVE VERSUS ON-LINE BATCH MICRO-MAINFRAME APPLICATIONS:
CORPORATE AND VENDOR VIEWS

MICRO-MAINFRAME
APPLICATIONS
WILL BE:

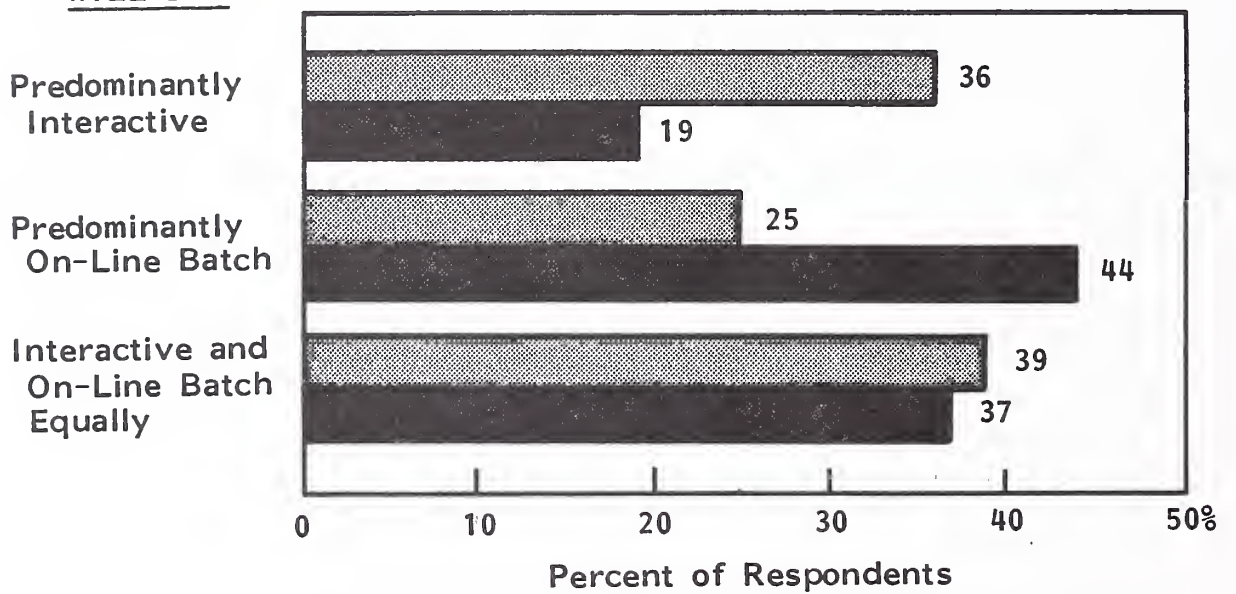



 Corporations
 Vendors

EXHIBIT IV-14

DEVELOPMENT STRATEGIES FOR APPLICATIONS SOFTWARE FOR MICRO-MAINFRAME SYSTEMS: CORPORATE AND VENDOR VIEWS

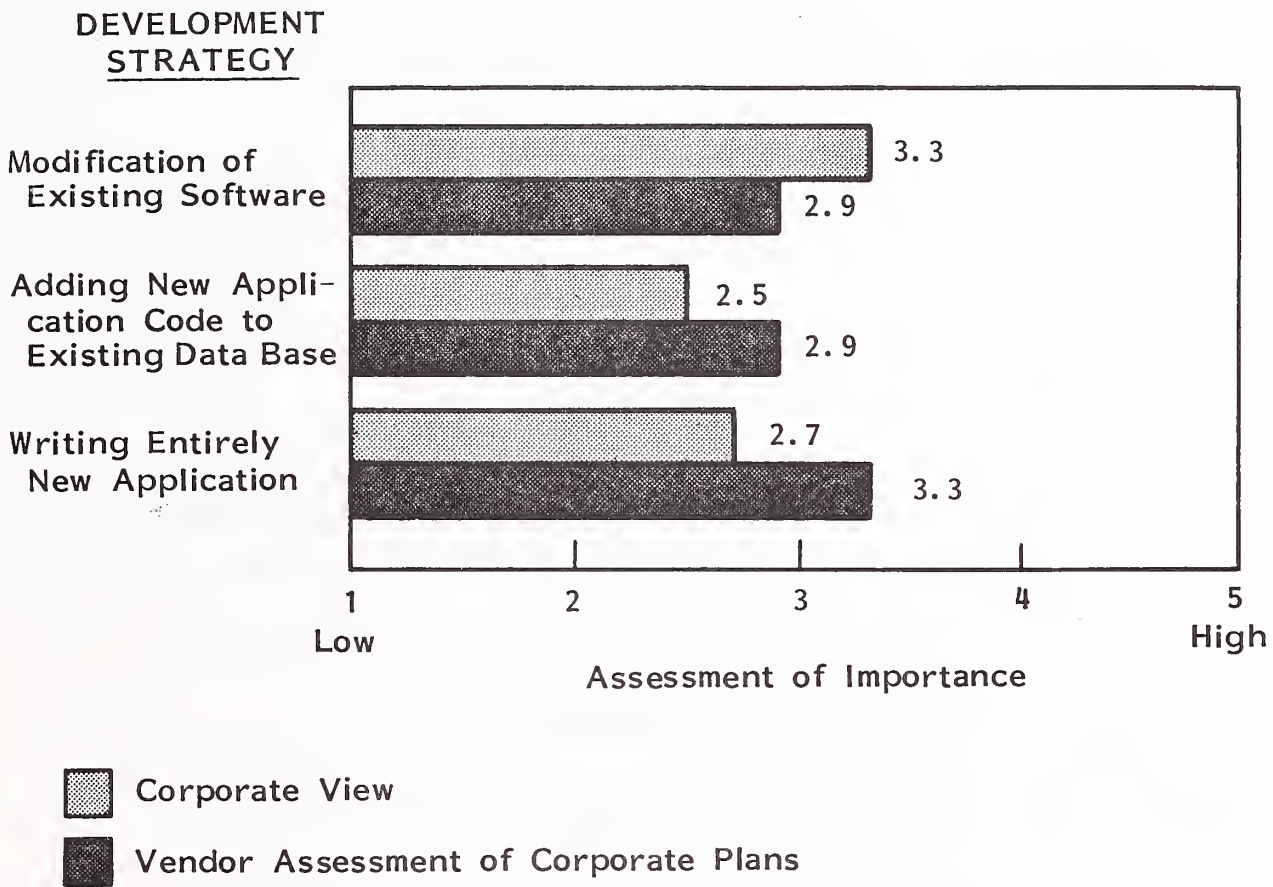

- INPUT believes that new applications will be needed for most non-trivial M-M applications because of the difficulty in retrofitting M-M applications to existing systems.
 - Consequently, even the vendor assessment of the need for new applications is almost certainly an understatement.
- Being committed to one particular strategy does not exclude support for other strategies. In fact, the corporations most in favor of a particular strategy supported other strategies as well, as shown in Exhibit IV-15.
- IS departments are not planning to go it alone. As reported earlier, most corporations have several M-M applications in place or in development.
 - Over half of these have relied on vendor assistance for at least part of the work, as shown in Exhibit IV-16.
 - However, for M-M projects in the planning or concept stage, fully 85% plan vendor involvement. This increase, in what was already a relatively large number, reflects:
 - More difficult M-M projects.
 - Increased vendor capabilities.
 - An increased awareness of vendor capabilities.
- The assistance received runs the gamut from:
 - Packages used without modification.

EXHIBIT IV-15

EXTENT TO WHICH A PARTICULAR
DEVELOPMENT STRATEGY SUPPORTS OTHER STRATEGIES

		② THEN ITS RATING OF THE FOLLOWING IS:		
		Modifying Existing Software	Adding Applications to Existing Data Base	Writing New Applications
① IF A COMPANY FAVORS	Modifying Existing Software	N/A	2.5	2.7
	Adding Application to Existing Data Base	3.5	N/A	3.2
	Writing New Applications	3.2	2.4	N/A
Average Rating		3.3	2.5	2.7

Rating: 1 = Low Importance, 5 = High Importance

N/A = Not Applicable

EXHIBIT IV-16

VENDOR INVOLVEMENT IN MICRO-MAINFRAME APPLICATIONS

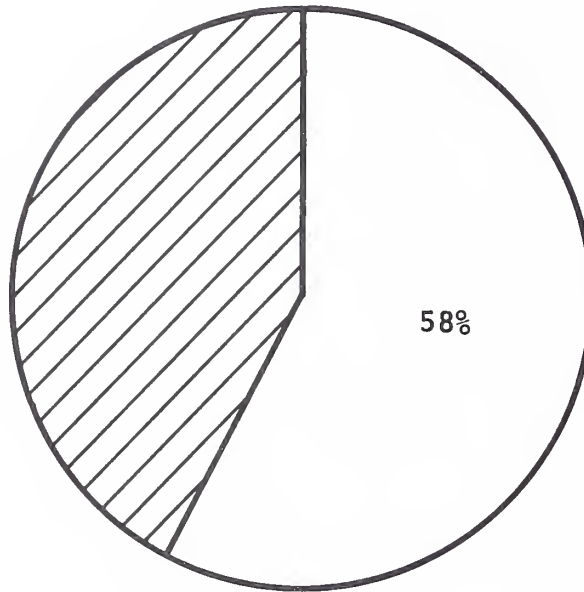

Currently Implemented or in Development

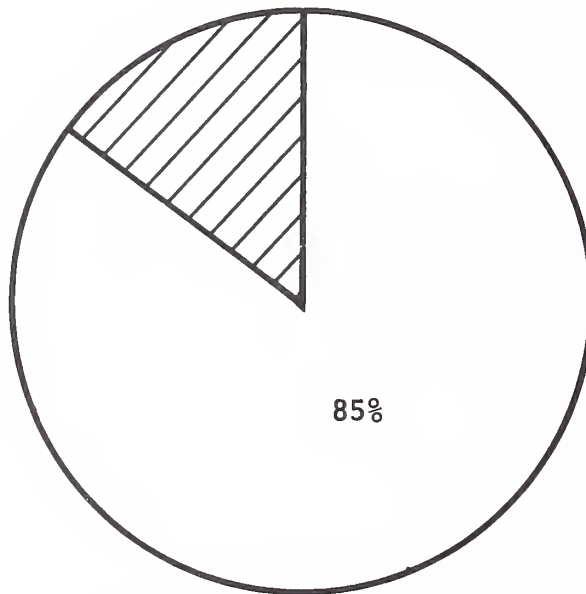

In Planning or Concept Stage

Vendor Involvement

In-House Implementation

- Packages used with extensive modification (quite common at this stage), with modification supplied by:
 - . In-house staff.
 - . Professional service firms.
- Custom programming from outside vendors.

V MICRO-MAINFRAME ISSUES

V MICRO-MAINFRAME ISSUES

A. TECHNOLOGY ISSUES

- There are three main technical issues affecting end-user M-M applications:
 - The XT/370.
 - UNIX.
 - Data synchronization.

I. THE XT/370

- In concept, the XT/370 allows users to "have their cake and eat it too."
 - The "mainframe" is brought to the desktop.
 - The user has control of VM/CMS (virtual machine/conversational monitor system).
 - The whole library of VM software, both systems software and applications software, is available for immediate use. These can include quite heavy duty applications.

- With the VM pass-through facility, XT/370 users can potentially link into many other VM systems.
- However, on closer inspection, the XT/370 as it exists today suffers from profound limitations.
 - The XT/370 is not, in fact, a standalone machine. Current chips do not provide good memory management.
 - Therefore, while CMS is on the XT/370, VM itself still must reside on the host.
 - As new chips (like the 286 or 386) with much better memory management are available, it could become possible to have a self-contained XT/370.
 - Similarly, coping with VM/CMS takes up most of the power and space in the XT/370.
 - There is little room left for applications. When applications were put experimentally on the XT/370, performance was found to be quite marginal and usually unfeasible.
 - However, the XT/370 does have sufficient resources to serve the purpose outlined for it in IBM's initial announcement—a programmer's workstation. Functioning in this manner, the XT/370 is not overloaded and can provide predictable response time.
- Apart from technical limitations (which, after all, can be solved by applying more hardware resources), there is the larger issue of whether host-developed applications should be (or, in some cases, can be) put on a desktop.

- "User friendly" is an overworked word but one that should be taken seriously when considering placing micro-based applications in user hands. Among the mounting criticisms of host-based systems in general are that they are difficult to:
 - . Learn.
 - . Use.
 - . Adapt.
 - . Control.
- Moving such unchanged applications out of the protective environment of the data processing professional and onto the desktop helps neither the end user nor IS.
- Host-oriented applications are not by nature susceptible to minor "tweaking" to make them suddenly user friendly.
 - . Most host applications assume large data bases, intricate processing logic, and a web of supporting systems software. Response time is something that is spread out between many dozens, if not thousands, of users.
 - . This maps poorly against the micro's strengths of having considerable amounts of processing power focused on relatively small amounts of data in order to provide exceptional response.
- A considerable number of organizations (corporations as well as vendors) do not fully appreciate these factors.

- Several corporations INPUT interviewed plan to use XT/370s in application settings.
- Two mainframe applications vendors have planned to put parts of their mainframe product onto the XT/370 as a way to get an "instant" micro product. One of these vendors attempting an instant product has already run into serious difficulties because of the capacity problems described above. (On the other hand, there are vendors like Information Builders, which rewrote FOCUS for the IBM PC.)
- However, as first mentioned, the concept of the XT/370 fills many of the requirements for a true M-M system, including:
 - High power.
 - Host connectivity (i.e., VM pass-through).
 - Shared operating system environment.
 - Data sharing.
 - Potentially, applications and application program segmentation.
- The promise of the XT/370 concept will be seen in later generations (the XT/3000?) and will have the capacity to do larger amounts of useful (i.e., applications) work. However, that will be only the first step.
 - It will be equally important, if not more so, to think through how applications logic and data should be distributed throughout the nodal network.
 - When this is done, it will represent a successful implementation of the early efforts of remote computing service (RCS) companies to dis-

tribute pieces of their applications onto micros. (The RCS firms' lack of success was caused by both technical limitations and commercially derived inhibitions against placing too much functionality in the micro.)

- Information Center activities would be a logical initial candidate, since solutions would be generalizable and under the control of IS.
- Applications segmentation would have to be approached much more carefully because of the increased time, expense, and coordination involved.
- Both IS and vendor respondents see the XT/370 playing at least a moderate role in the future, as shown in Exhibit V-1.
 - INPUT knows that some of these positive assessments are based on a misunderstanding of the XT/370's current capabilities.
 - Consequently, IS management should be very careful in verifying any claims regarding the application virtues of the XT/370 as it now exists.

2. UNIX

- It is beyond the scope of this report to fully assess the current and future claims being made concerning UNIX. (For additional analysis, see INPUT's Executive Bulletin, An Unusually Noteworthy Introduction of a Xenolith. However, the following facts should be kept in mind:
 - It is true that considerable percentage growth is being planned for UNIX-based micro hardware; however, this is starting from a very low base (0.1%) currently and will reach only 1.0% in 1986, among the INPUT respondents.

EXHIBIT V-1

FUTURE IMPORTANCE OF XT/370 TO SELECTED GROUPS

Company Respondents*

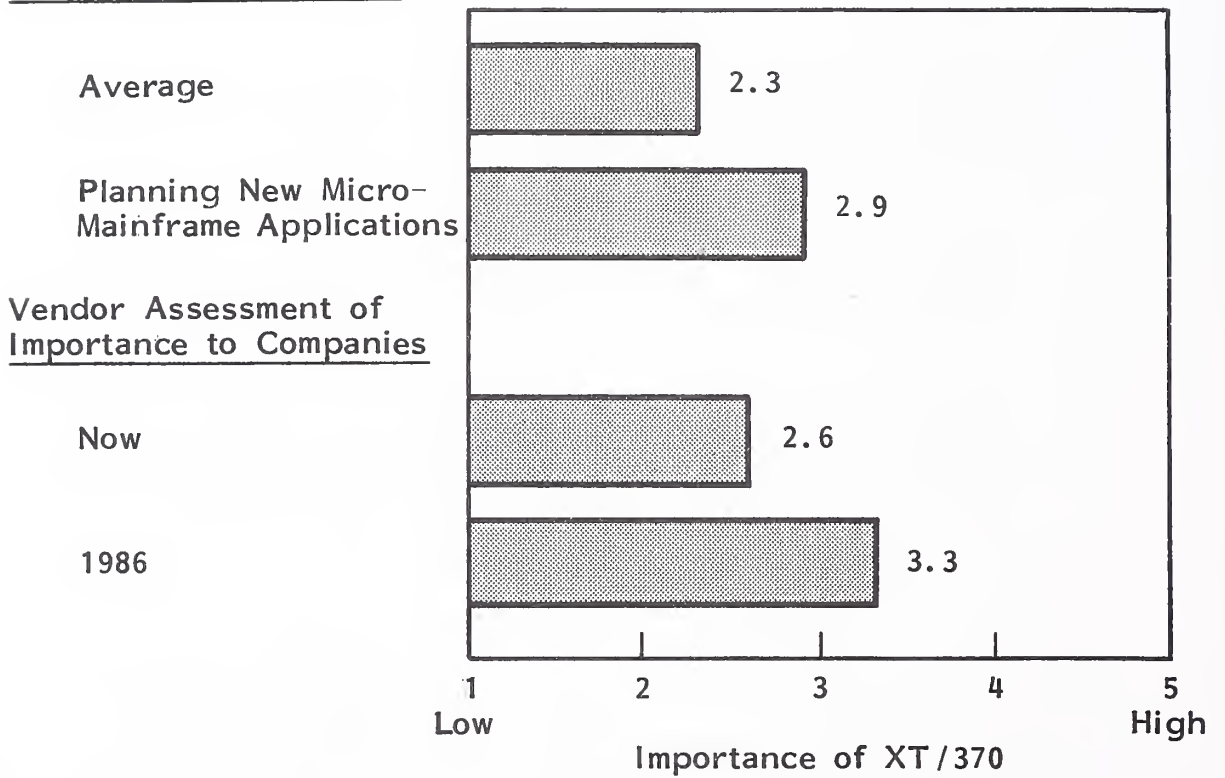

* Future Use

- Most IS respondents saw UNIX as even less important than the XT/370 in their future plans, as shown in Exhibit V-2.
- The plethora of UNIX-like systems will discourage major software vendors from developing UNIX-based applications.
- It is true that UNIX's portability and ability to network between machines makes it appealing as a potential M-M vehicle.
 - However, this potential is largely untested in a corporate environment; much of the academic and scientific experience with UNIX is not pertinent for major business users. (See INPUT's 1983 report Selecting User Friendly Operating Systems for Personal Computers.)
 - Most importantly and for some time to come, micro applications will have to link into conventional MVS or CMS systems. UNIX will have no more advantage than any other micro-based environment.

3. DATA SYNCHRONIZATION

- Data synchronization and data security issues generally are dealt with in more detail in this study's companion report, Micro-Mainframe: Communications Issues.
- However, the special case of synchronization, as shown in Exhibit V-3, directly impacts M-M system design and user feasibility issues. The facts as they stand are:
 - Data synchronization of updates on a real-time basis between an independently processing mainframe and a micro is not feasible now.
 - Potentially, one or more of the relational DBMS vendors may find a solution to the concurrency, multiple-update, and lockout problems.

EXHIBIT V-2

XT/370 AND UNIX:
FUTURE IMPORTANCE AND CURRENT UNDERSTANDING

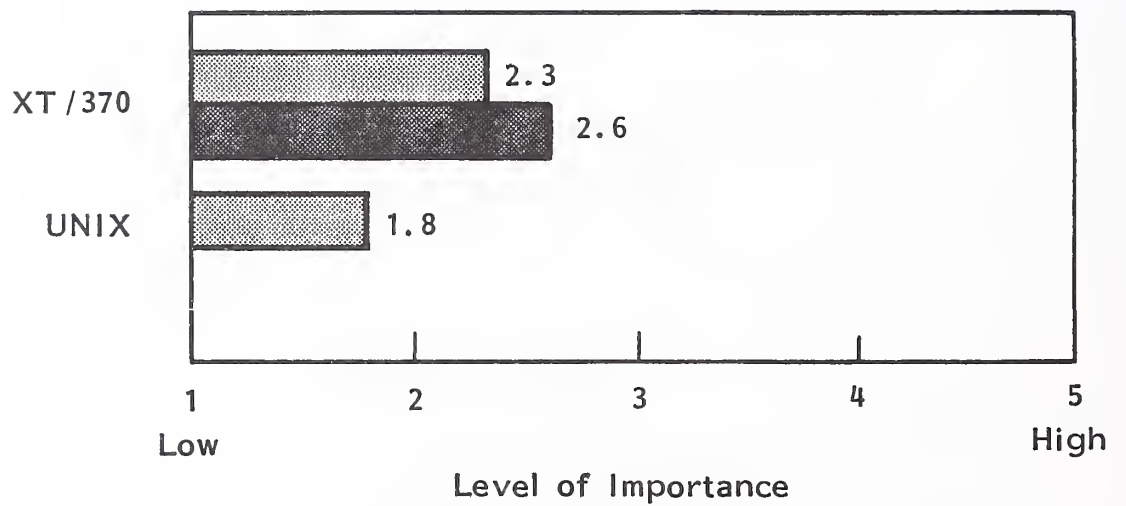

- Future Importance to Company
- Current Understanding of Product by Company

EXHIBIT V-3

PROBLEMS IN MICRO-MAINFRAME CONNECTIVITY

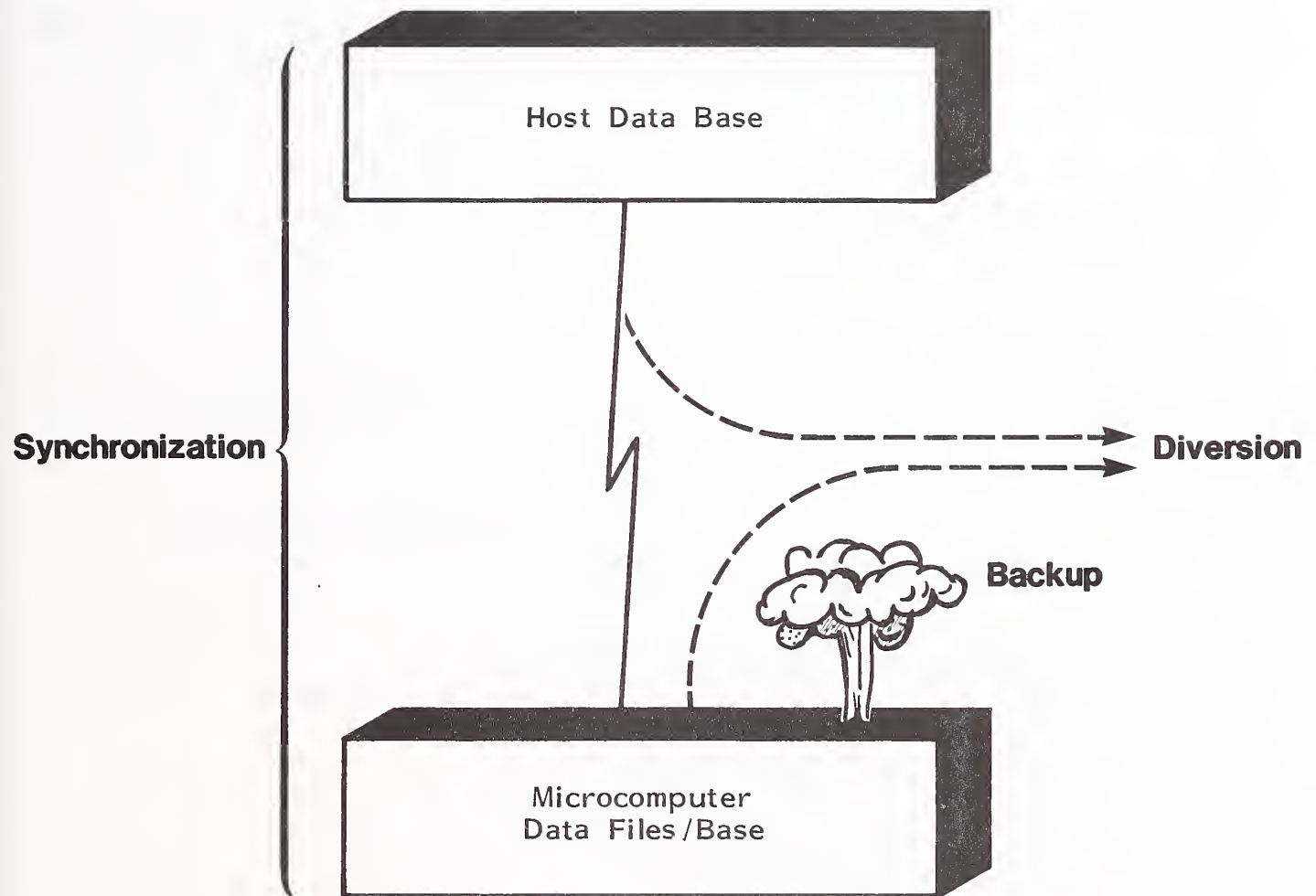

Even if this is accomplished, these solutions in their initial versions will be both slow and inefficient. Thus, it is assumed that there cannot be any routine solution for these problems for some time to come.

- Consequently, the expressed desire for truly interactive M-M applications probably cannot be satisfied for several years, at best.
- However, on-line batch solutions may be acceptable in many situations. These are discussed at greater length in the next chapter.

B. PLANNING ISSUES

- In planning for M-M applications, planners must judge how M-M performs relative to traditional mainframe-based--as well as micro-based--systems, using a number of criteria, including:
 - Data linkage across applications.
 - Application transparency.
 - Environmental adaptability.
 - Potential for central control.
 - Flexibility in meeting user needs.
 - Stability.
 - Data synchronization.
 - Operation economy.

- Operation speed.
- Implementation speed.
- Data linkage: Although DBMSs were originally conceived to unite data across applications, in practice it has often proved infeasible to do so because of complexity, control, and flexibility problems. These problems are worse in micros because of the relatively limited hardware and software environments.
 - At present, of course, linkages across M-M applications are not technically possible in a real-time environment.
 - On a batch basis they are only feasible where micro applications are treated as intelligent terminals feeding transactions to the mainframe system.
- Application transparency: This is the extent to which an application can be understood or comprehended, from both the user level and a technical level.
 - Many host-based applications, because of their size and complexity, are rather opaque.
 - On the other hand, micro-based systems--being smaller and closer to the end user--are much more comprehensible.
 - M-M applications have the potential danger of adding yet another layer of complexity to host systems. To the extent that the host "system" is largely a data repository, this danger can be alleviated by placing as many logical and processing functions as possible at the micro level.
- Environmental adaptability: This is the extent to which physical environments can be changed (e.g., adding terminals to SNA systems) or an application can

be moved to a new hardware or systems software environment. Host-based systems are adequate but clumsy in this regard. Micro systems are more hardware-bound.

- Potentially, UNIX-based systems allow an evolutionary path for both micro and M-M applications.
 - However, UNIX is quite large (around nine megabytes) and is still essentially an unknown quantity in regard to commercial applications. The very profusion of UNIX variants makes any claim for universality a hollow one at this stage. (See the previous section on UNIX.)
 - Otherwise, M-M applications would be even more environment-bound than their mainframe cousins.
- Potential for central control: Here host-based systems are obviously much superior to micro applications. M-M applications are at an intermediate point.
 - User flexibility: Mainframe systems are notorious for their inflexibility (at least in user eyes), and micro systems (fairly or unfairly) are considered unbeatable. Depending on how tightly coupled to the host an M-M application is, it could be closer to a standalone micro system or as bad as (or worse than) a mainframe system. (Micro applications written in assembler language are, of course, another problem altogether.)
 - Stability: This is meant the extent to which an application's operations are error- and failure-free. While mainframe applications still have a long way to go, there are many facilities built into the hardware and software environment to assist in maintaining operations. Micro systems by nature are considerably more fragile, being without the supporting infrastructure one is accustomed to seeing in mainframe systems (e.g., audit tools).

- Data synchronization: Here the situation is very similar to the "stability" area above. This leaves out the current unsolved problem of synchronizing data in an interactive M-M environment.
- Operation economy and operation speed: Both micro and M-M applications can potentially be much better or worse than their mainframe equivalents.
- Implementation speed: Although large, complex mainframe systems often take years to implement, an M-M system that was implemented like a mainframe system would be worse. M-M systems that have more in common with off-the-shelf micro applications would be infinitely superior. However, modifying micro packages is itself an undertaking that can be difficult and frustrating.
- Exhibit V-4 summarizes the performance of each of the three implementation approaches and gives them a "grade" for each factor.
 - There is no obvious choice at present between the three alternatives: all have their strong and weak points.
 - The path selected should be one that maps best against the corporate environment, IS capability, and application needs.
 - M-M applications have the greatest scope for improvement. At least potentially, M-M applications could be superior to either of their parents.

EXHIBIT V-4

ADEQUACY OF SYSTEM IMPLEMENTATION APPROACHES

CRITERIA	RATINGS OF IMPLEMENTATION APPROACHES		
	TRADITIONAL MAINFRAME-BASED	MICRO-BASED	MICRO/ MAINFRAME-BASED
Data Linkage Across Applications	C-	D	D-
Application Transparency	C	A	B to D
Environmental Adaptability	C	D*	D*
Potential for Central Control	B	F	C
Flexibility in Meeting User Needs	C-	A	B to D
Stability	C+	D*	D*
Data Synchronization	C+	D	D
Operation Economy	C	A to D	B to D
Operation Speed	B	A to F	A to D
Implementation Speed	D	A	A to D-

Key: A = Meets criteria best

F = Does not meet criteria

* Potential for one or more grade improvement

VI RECOMMENDATIONS

VI RECOMMENDATIONS

- These recommendations are divided into three categories:
 - Technical approaches.
 - End-user relationship building.
 - Vendor partnerships.

A. TECHNICAL APPROACHES

I. LOW RISK: DATA DOWNLOADING

a. An Entry Strategy

- IS should select an important, but technically unambitious, user area that:
 - Uses a significant number of standalone PCs.
 - Rekeys corporate data.
 - Uses data from a software vendor product that has a proprietary down-loader.

- IS should ascertain that the department has at least a moderate amount of interest and commitment to downloading data.
- If all these requirements are met, then IS should:
 - Analyze the data needed.
 - Provide an extract file.
 - Set up inquiry and/or scheduled downloading.
- At every step, IS should carefully explain what is and is not possible using this approach.
- This approach will begin serious M-M work in a controlled environment. With successes behind it, any caution that IS shows toward more ambitious and technically demanding M-M projects will be better accepted.

b. Standards

- Ironically, standard setting, if done too early, could be a high-risk alternative since IS departments would then be locked into obsolescent technology.
- Since there are currently no obvious product winners from a technological standpoint and since there will be a next generation of products soon, the standard setting should be limited. That is:
 - The number of current M-M link products used should be kept at a reasonable number (a maximum, say, of four to six).
 - Where there is a significant investment in proprietary software (e.g., from MSA, Cullinet, McCormack & Dodge), that vendor's link package should be used if there is user demand for that data.

- Implementations should be relatively inexpensive and reversible. The more an application is bound to a current vendor's technology and the more important the application, the more difficult it will be to change direction. (This is, of course, the vendor's objective.)

c. The Information Center as a Connectivity Tool

- In many people's minds the Information Center has gone into a shadow as a result of the advance of PCs. It may also be eclipsed by M-M linkages.
- Looking back, one sees that much of the problem is caused by the relatively low level of support and user friendliness in many Information Centers. Partly, this was a historical accident in that many Information Centers were established at the start of the recent recession, and they were starved for funds.
- At least as an interim step, the Information Center has a role to play as a staging area for extracted files that can be downloaded. For later implementation of M-M applications, the Information Center will be bypassed where production data files are used.

2. LOW/MEDIUM RISK: DEVELOPING AN ON-LINE BATCH STRATEGY

- IS departments developing an on-line batch strategy must steer a careful course.
 - The micro must be sufficiently isolated from the host system so that input and output can be viewed essentially as file transfers. This is true even if the data transfers are very short and frequent--i.e., transactions, as shown in Exhibit VI-1.

EXHIBIT VI-1

ON-LINE BATCH-DATA TRANSFERS

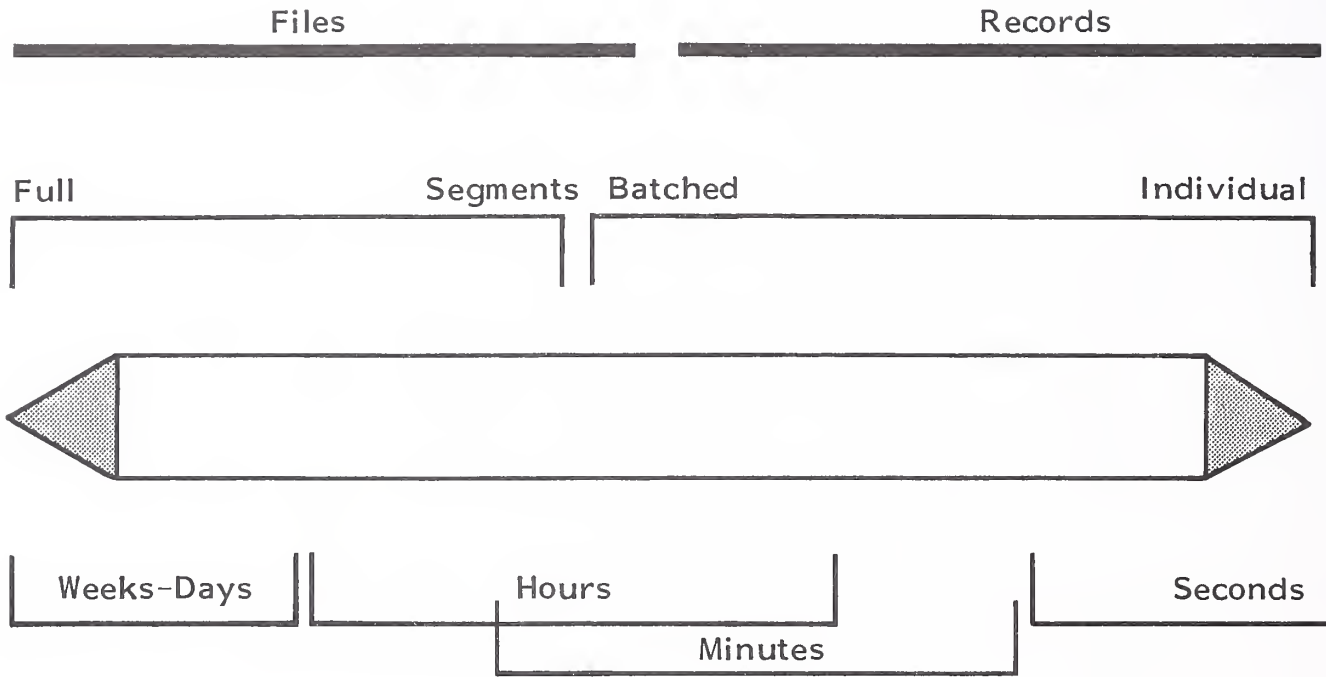

- On the other hand, if the micro system becomes too isolated, essential central coordination and control is absent.
- Exhibit VI-2 shows a conceptual micro applications post-processor that would be interposed between the micro application and data base, and the central data base.
- This kind of post-processor will help to close the gap that will arise between processing steps at the micro level that are recognized as host transactions and other host data base changes that are not normally host system transactions.
- Developing such interface procedures will be necessary in order to meet the "next-generation" M-M applications described in the case studies in Chapter III.

3. HIGH RISK: INTERACTIVE APPLICATIONS

- Interactive applications may become feasible, at least on an experimental basis, in the medium term (three to five years), although it will almost certainly be much longer before interactive applications are routinely used.
- Section C of this chapter describes strategies for working with vendors. Such partnerships would reduce the risk and allow for sooner implementation of interactive applications.

B. END-USER RELATIONSHIP BUILDING

- Because of the nature of M-M applications, much of the activity will have to take place at user locations. This makes the quality of the relationship between end users and IS important. Executive-level relationships will

EXHIBIT VI-2

DATA BASE POST-PROCESSOR: LIMITS EXCESSIVE MICRO INDEPENDENCE

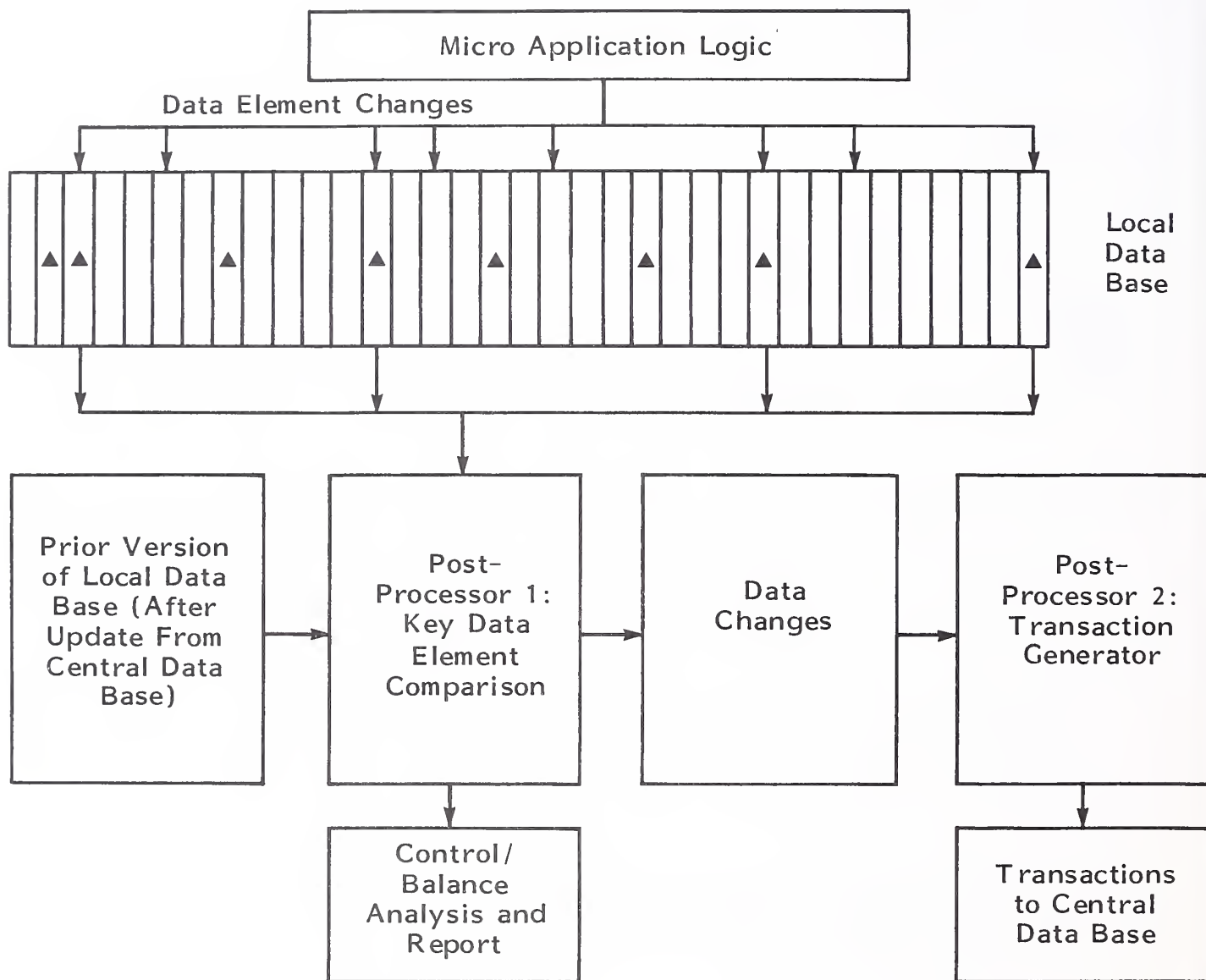

▲ = Data Elements Common to Host and Local Data Bases (Key Data Elements)

generally be even more important. The areas that should receive focus include:

- Improving relationships generally.
- Improving PC-related services.
- Changing the IS organization.

I. GENERAL I.S.-USER RELATIONSHIP IMPROVEMENTS

- It is beyond the scope of this report to review all the things that could be done to improve IS-user relationships.
 - Most of the findings and recommendations in INPUT's 1982 report, Evaluating the EDP Level of Service, are still valid (and unfortunately are needed in almost as many organizations as before).
 - Several key points from the earlier report are reprinted here in Appendix D for readers' convenience.
- It is especially important that end users have confidence in IS's good intentions and knowledge when IS provides advice on M-M issues. Policies to achieve this include:
 - Regular meetings with key user staff.
 - Frankness on issues and problems; unnecessary jargon should be avoided.
 - Semi-technical briefings on IS issues in general and M-M issues in particular.

- A "marketing" approach to IS service by IS (complete with "marketing reps" if resources are available).
- Keeping a "book" on key operations units to understand what motivates their systems requirements. Business planning documents are useful, but personal contact is even more useful.

2. PC SERVICES

- Much existing IS PC support is inadequate in terms of quality, quantity, and coverage. However, it is even more critical now to provide this support than it was in the past.
 - PC support was the subject of a 1982 INPUT study, Supporting Personal Computer Software. The recommendations given in that study are still valid; consequently, all the attributes of PC support will not be detailed here.
 - A summary of these earlier recommendations is contained in Appendix E.
- The PC support function is more important than before for two reasons:
 - The more that users (and IS) are educated on the true capabilities of micros, the less likely they are to go chasing after impossible and/or dangerous M-M applications.
 - The PC support function, reporting to IS, can provide an excellent early warning system for users' M-M intentions.
 - IS can work with users to construct M-M systems that all sides can live with.

- At the least, IS has more time to head off poorly considered initiatives, mobilizing countervailing forces if need be.

3. ORGANIZATIONAL CHANGES

- Many IS organizations are considering, and some have implemented, a partial or full decentralization of their application-related functions.

- At the least, this can take the form of physical decentralization, with the units still reporting to IS, as shown in Exhibit VI-3.

- M-M applications can add another dimension to this, as shown in Exhibit VI-4.

- Some of the physically decentralized units can become organizationally decentralized also.

- Corporations may wish to experiment with both approaches to see which works best; i.e., should the organization's structure be skewed more to the "micro" or to the "mainframe"?

- The exact arrangements will vary depending on such factors as:

- The corporate culture.

- User-IS relations.

- Amount of technical complexity of systems in the corporation.

- Size of decentralized units.

- Amount of strategic business unit (SBU) application independence.

- SBU willingness/ability to manage a technical function.

EXHIBIT VI-3

ORGANIZATIONAL EVOLUTION INTO THE
MICRO-MAINFRAME ENVIRONMENT (Phase 1)

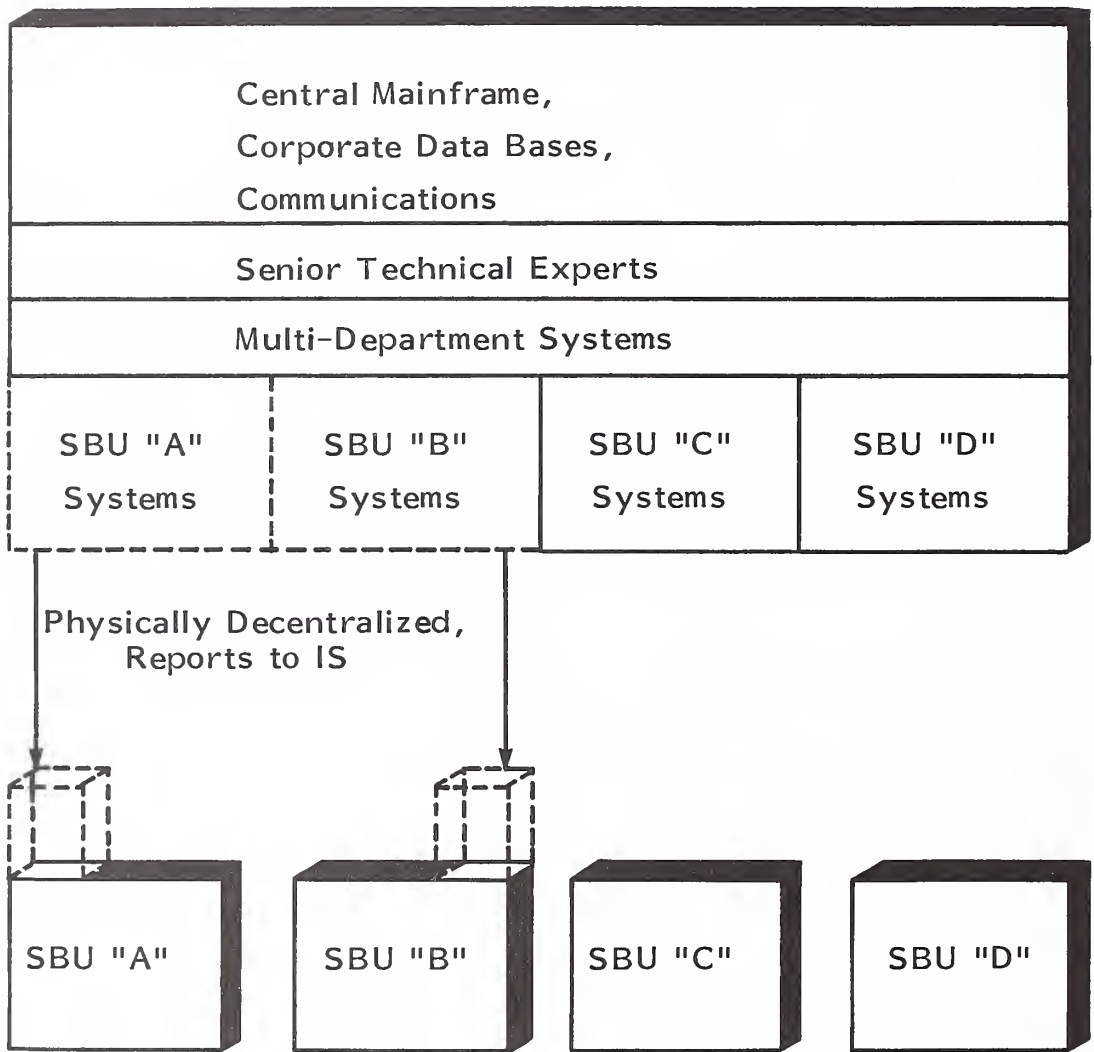
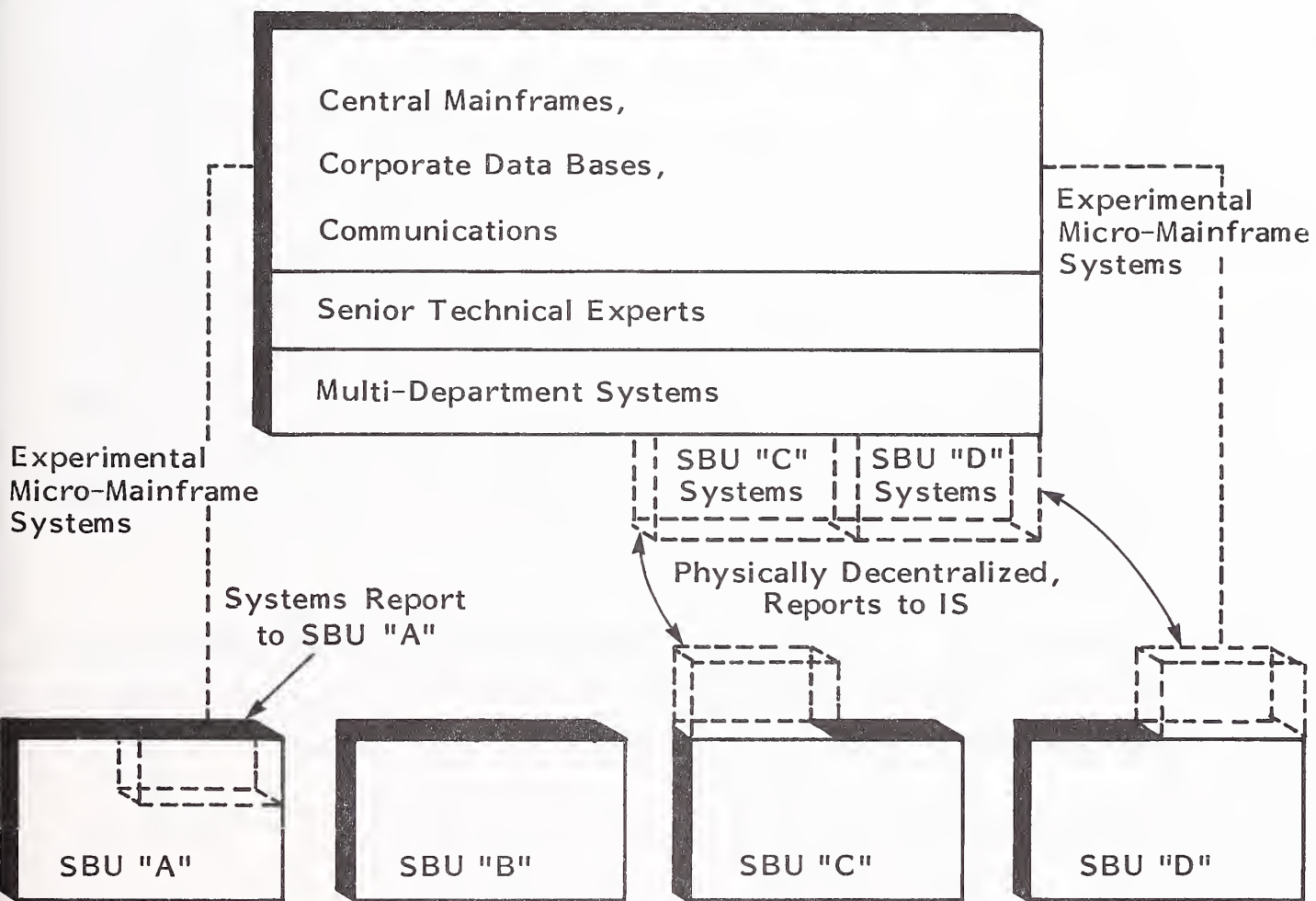

EXHIBIT VI-4

ORGANIZATIONAL EVOLUTION INTO THE
MICRO-MAINFRAME ENVIRONMENT (Phase 2)



- Ultimately, the IS-related organization could evolve into something similar to that in Exhibit VI-5.

C. VENDOR PARTNERSHIPS

- One of the findings in Chapter III was that the adequacy of technical M-M arrangements is one of the chief determinants of M-M application success.
 - A key finding in Chapter IV was that interactive, shared functionality M-M applications were a goal for most organizations.
 - Unfortunately, the discussion in Chapter V indicated that this sort of application will not be technically feasible for some time to come.
- While on-line batch systems will often be effective, they will not always satisfy minimal user requirements (for example, in a securities- or currency-trading environment) and will often ultimately leave many users somewhat dissatisfied.
- Vendors live by satisfying users. Consequently, large IS organizations would do well to enter into cooperative arrangements with one or more vendors to find technical M-M solutions that work in a real organization.
 - IS would contribute:
 - A test bed.
 - Machine time.
 - Business and systems analysts.
 - Technical support and assistance.

EXHIBIT VI-5

ORGANIZATIONAL EVOLUTION INTO THE
MICRO-MAINFRAME ENVIRONMENT
(Phase 3)

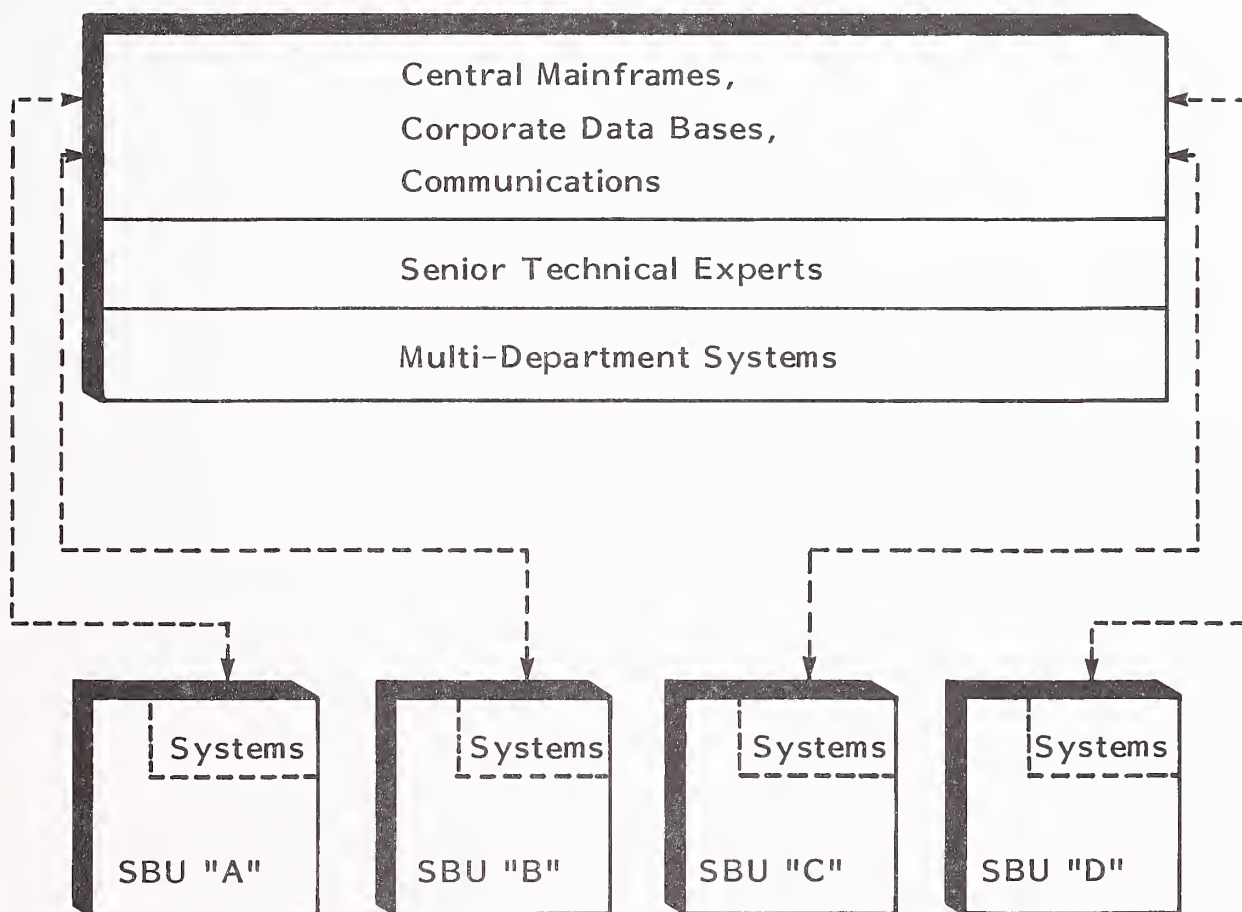

All "owned" application system functions are physically located in and report to their SBUs.

- The vendor(s) would contribute:
 - Technical expertise.
 - Advice on workable/unworkable alternatives.
 - Product prototypes.
- Corporations could stay at the leading edge technically while solving real business problems. There would have to be some limits on the relationship.
 - IS (and individual staff members) would have to adhere to reasonable vendor requirements to maintain security on what, after all, could be a valuable product.
 - There would have to be a "no raiding" agreement on each other's personnel.
- Both small and large vendors have their attractions.
 - Large vendors have more products and a larger market share. Often there may be a pre-existing relationship between IS and a vendor to build on.
 - Smaller vendors may be more innovative and "hungrier"; they may, however, be almost paranoid about secrecy.
- Research partnerships that work out well could result in a more permanent business arrangement, including:
 - Corporate IS playing a more active role in product development.
 - The corporation and/or IS taking a stake in promising companies.

**APPENDIX A: MICRO-MAINFRAME USER
QUESTIONNAIRE**

MICRO-MAINFRAME USER QUESTIONNAIRE

INPUT is conducting a study on the issues involved in linking microcomputer host systems and data. We will make recommendations on how corporations can best deal with these issues in the coming years. We would like your organization to take part in this study by describing what you are doing now, what your plans are and what problems you see. This information will be used by IS departments in their planning and will also be used by a wide variety of information service vendors to offer more useful products and services.

None of the information that you provide will be associated with your company. In return for your taking part in this study, we will send you a summary of this study on its completion and will also send you a summary of INPUT's report, PC Software Support in Large Corporations.

1. How many personal computers are in use within your company? (If no PCs are used or planned by the end of 1985, end interview.)

	Now	End of 1984	End of 1985
Total all types	_____	_____	_____
IBM PC XT/370 or 3270/PC	_____	_____	_____
IBM PC except XT/370 or 3270/PC and IBM PC SW/data-compatible types	_____	_____	_____
UNIX-based systems	_____	_____	_____
Other personal computer types	_____	_____	_____
(Total should equal sum of parts)			

2a. How will the UNIX-based systems be used? _____

2b. In the future, how important do you see UNIX-based systems being to your organization's plans? (1 = low importance, 5 = high importance)

UNIX-based systems _____

Why? _____

3a. In the long run, how important do you see the XT/370 in your organization's plans? (1 = low importance, 5 = high importance)

XT/370 _____

Why? _____

The 3270/PC? _____

Why? _____

3b. How well would you rate your organization's current understanding of the capabilities of the XT/370 and the 3270/PC? (1 = low degree of understanding, 5 = high degree of understanding)

XT/370 _____ 3270/PC _____

Please give me some examples of particular areas where your organization requires additional information on the capabilities of the XT/370 and the 3270/PC. (PROMPT AS NECESSARY: for example, what has to be done to permit current applications software to run on the XT/370, how will concurrent data bases be handled, etc.)

XT/370 _____

3270/PC _____

4a. How many multiuser microcomputer systems (e.g., Altos) and local area networks (LANs) do you now have installed? Who are the vendors? What are these systems being used for?

	Multiuser Micros	LAN
Number of installations	_____	_____
Vendors	_____	_____
Applications/Uses	_____	_____

4b. How many multiuser micros and local area networks do you expect to have installed in two years? What new uses will you have?

	Multiuser Micros	LANs
Number of installations	_____	_____
Vendors	_____	_____
Applications/Uses	_____	_____

5. In the future, what will the relative importance be to your organization of the following kinds of microcomputers? (1 = low importance, 5 = high importance) Why? (READ EACH ITEM BELOW)

	Rating	Reason Why
Standalone personal computers running personal computer software? (e.g., IBM PC/XT)	_____	_____ _____
Standalone personal computers running mainframe software?	_____	_____ _____
Personal computers in local area networks?	_____	_____ _____
Mainframe terminals that also have personal computer capabilities (e.g., 3270/PC)	_____	_____ _____

6. On a scale of 1 to 5 with 1 representing low importance and 5 representing high importance, how would you rate the following functional areas? In two years how would your importance rating change for these? Why the change?

	<u>Now</u>	<u>Two Years</u>	<u>Reason for Change</u>
Spreadsheet packages using local data	_____	_____	_____

Spreadsheet packages using downloaded data	_____	_____	_____
---	-------	-------	-------

Vendor application packages for PCs	_____	_____	_____
--	-------	-------	-------

In-house developed programs for PCs (including fourth generation languages)	_____	_____	_____
--	-------	-------	-------

7a. The next set of questions relate to so-called micro-mainframe application systems. For the purposes of this study, we are defining this to mean the following: "Applications in which neither the mainframe host nor a microcomputer can fully carry out an activity without utilizing processing capabilities or data from the other." Do you agree with this definition?

Yes No

7b. If no, please tell me how you would modify it: _____

8. With +5 representing agreement and -5 representing disagreement, to what extent do you agree that "Within three to five years most applications that are now host-based will have a considerable amount of functionality taken over by personal computers that are linked to the host." _____

Why? _____

9. Do you believe that links between host computers and micros will be predominantly interactive, predominately on-line batch, or about the same? (READ DEFINITION IF NEEDED)

DEFINITION: ON-LINE BATCH - where the micro performs processing on a standalone basis and, periodically, the personal computer and the host exchange data; the host may then further process the data received.

- Predominantly interactive
- Predominantly on-line batch
- About the same

Reason why _____

10. In constructing micro-mainframe systems how common do you think each of the following approaches will be? (READ LIST BELOW) Why? (1 = very common, 5 = not common) NOTE: ALL OPTIONS MAY BE RATED "NOT COMMON" OR "VERY COMMON" - OPTIONS ARE NOT MUTUALLY EXCLUSIVE.

	<u>Rating</u>	<u>Reason Why</u>
Modification of existing software	_____	_____
Use existing data base but write new application code	_____	_____
Write entirely new applications	_____	_____

11a. Generally, to what extent do you see data base linkage and synchronization as a serious problem in establishing micro-mainframe links? (1 = not a problem, 5 = a serious problem) _____

11b. How serious is this problem for systems used for analysis? (e.g., spreadsheets) _____

Why? _____

11c. How serious is this problem for production systems? (e.g., order entry, payroll) _____

Why? _____

11d. What can an organization like yours do to solve these kinds of data base linkage and synchronization problems?

12a. Do you see backup and security as significant barriers to expanded use of linked micro-mainframe applications?

Yes No If no, skip to question 13.

12b. What are the major problems that you see? _____

12c. What can an organization like yours do to solve these problems?

12d. What solutions can vendors provide? _____

13a. For your own organization, what specific applications do you see as being the most suitable as micro-mainframe applications? (They need not be computerized applications now.) (Use workspace below.)

13b. Are these applications planned and if so, at what stage are you in implementing them (i.e., do not have concrete plans, are in the planning stage, applications are being developed, applications are already implemented)? (Use workspace below.)

13c. Do you expect to develop these applications in-house, purchase an existing package from an outside vendor, or modify in-house an existing package? (Use workspace below.)

Application Name	Stage				Source		
	None	Plan	Dev.	Imp.	In-house	Vendor	Both
1.							
2.							
3.							
4.							
5.							

Comments:

- 1. _____
- 2. _____
- 3. _____
- 4. _____
- 5. _____

14a. Do you have electronic mail? Yes No
If no, skip to question 15.

14b. How many users currently use the electronic mail now? In two years?
Now _____ Total in two years _____

14c. On the average, how many messages are now sent via electronic mail per month? In two years?
Now _____ Total in two years _____

14d. What percentage of this change in electronic mail use do you expect to be attributable to microcomputers? _____ %

15a. In what ways do you see micro-mainframe applications increasing your data communications requirements?

15b. In what ways do you see micro-mainframe applications decreasing your data communications requirements?

15c. Overall, do you think that the net effect will be to increase or decrease your data communications requirements? By what percent?

Increase: _____% Decrease: _____% No effect: _____

16a. With 1 representing low importance and 5 representing high importance, how important will it be for your company's micros to communicate with micros in other departments? _____

Why? _____

16b. What type of communication facility will your firm be likely to use for this type of communication? (Use matrix on following page.)

17a. With 1 representing low importance and 5 representing high importance, how important will it be for your company's micros to communicate with mainframes in other companies (i.e., suppliers, customer)? _____

Why? _____

17b. What types of communication facilities will your firm be likely to use for this type of communication? (Use workspace on following page.)

18a. With 1 representing low importance and 5 representing high importance, how important will it be for your company's micros to communicate with public data bases? _____

Why? _____

18b. What types of communication facilities will your firm be likely to use for this type of communication? (Use workspace below.)

Type of Communication Facility	Micros in Other Departments	Mainframes in Other Companies	Public Data Bases
LAN			
Existing network			
Leased lines			
WATS			
Dial up			
Public data network			
Other			

19a. Do you expect your company's micros to be linked to more than one type of mainframe (e.g., IBM and DEC)? Yes No
If no, skip to question 20.

19b. What would be the most common types of mainframe linkages?

19c. Would, typically, the same micro have to link to more than one kind of mainframe at different times? Yes No

20a. Do you expect that your company's micros will have to be linked to more than one type teleprocessing environment (e.g., to both TSO and CMS, or to CICS and IMS DC)? Yes No

If yes:

20b. Which ones? _____

20c. Would, typically the same micro have to link to more than one kind of software environment at different times? Yes No

21a. Do you expect that your company's micros will be linked to more than one type of data base management system (e.g., to both IMS and IDMS)? Yes No

If yes:

21b. Which ones? _____

21c. Would, typically, the same micro have to link to more than one kind of DBMS at different times? Yes No

22a. Do you expect microcomputer use in your company to accelerate the use of relational data base systems in your company? Yes No

If no, skip to question 23.

22b. Which one? _____

22c. Would this data base be located on a regular mainframe or have a special machine devoted to it? IF SPECIAL MACHINE: Which one?

23a. With 1 representing no assistance and 5 representing much assistance, how much assistance generally do you expect to be able to get from vendors in helping with planning and implementing your organization's critical micro-mainframe applications? _____

23b. More specifically, how would you rate:

<u>Vendor Type</u>	<u>Rating</u>	<u>Reason Why</u>
Microcomputer hardware vendors	_____	_____
IBM	_____	_____
Software vendors who primarily offer mainframe software	_____	_____
Software vendors who offer both mainframe and microcomputer software	_____	_____
Remote processing (timesharing) vendors (e.g., McAuto, Boeing Computer Services)	_____	_____
Integrated systems (turnkey) vendors	_____	_____
Professional services and consulting firms	_____	_____

24. What current problems do you see micro-mainframe systems solving or alleviating?

25a. What problems do you see being created or aggravated by micro-mainframe systems?

25b. How do you think these new problems should be dealt with?

THANK YOU.

APPENDIX B: CORPORATE RESPONDENT PROFILE

APPENDIX B: CORPORATE RESPONDENT PROFILE

- The 78 corporate respondents were in the following industrial sectors:
 - Process Manufacturing: 26.
 - Banking and Finance: 18.
 - Discrete Manufacturing: 16.
 - Services: 11.
 - Insurance: 7.
- Large corporations (i.e., revenues of over \$2 billion) accounted for 42 of the respondents. Smaller organizations (revenues between \$500 million and \$2 billion) had 36 of the respondents.
- As noted in the body of the report, there were generally few respondent differences that correlated with industry sector or company size.

**APPENDIX C: MICRO-MAINFRAME VENDOR
QUESTIONNAIRE**

MICRO-MAINFRAME VENDOR QUESTIONNAIRE

INPUT is conducting a study on the issues involved in linking microcomputer host systems and data. We will make market forecasts on related products and services. We would like your organization to take part in this study by describing what you are doing now, what your plans are, and what problems you see. This information will be used by IS departments in their planning also.

None of the information that you provide will be associated with your company unless you wish otherwise. In return for your taking part in this study, we will send you a summary of this study on its completion and will also send you a summary of INPUT's report, PC Software Support in Large Corporations.

1. Which microcomputer hardware and software environments in the following list does your company expect to be important for micro-mainframe applications in 1984 and in 1986? (1 = low importance, 5 = high importance) Why?

	End of		<u>Reasons</u>
	<u>1984</u>	<u>1986</u>	
IBM PC AND PC/XT	_____	_____	_____
IBM XT/370	_____	_____	_____
IBM 3270/PC	_____	_____	_____
UNIX-based products	_____	_____	_____
Other micro hardware (describe)	_____	_____	_____
Other micro software (describe)	_____	_____	_____

2. What do you see as the major opportunity areas in connection with the XT/370 and the 3270/PC?

XT/370 _____

3270/PC _____

What do you see as limiting the growth in supplying software specifically aimed at the XT/370 and 3270/PC?

3. In the future, what will the relative importance be of the following kinds of microcomputers? (1 = low importance, 5 = high importance) Why? (READ EACH ITEM BELOW)

	<u>Rating</u>	<u>Reason Why</u>
Standalone personal computers running personal computer software? (e.g., IBM PC/XT)	_____	_____
Standalone personal computers running mainframe software? (e.g., XT/370)	_____	_____
Personal computers in local area networks?	_____	_____
Mainframe terminals that also have personal computer capabilities (e.g., 3270/PC)	_____	_____

4. On a scale of 1 to 5 with 1 representing low importance to corporate users and 5 representing high importance, how would you rate the following functional areas? In two years how would your importance rating change for these? Why the change?

	<u>Now</u>	<u>Two Years</u>	<u>Reason for Change</u>
Spreadsheet packages using local data	_____	_____	_____
Spreadsheet packages using downloaded data	_____	_____	_____
Vendor application packages for PCs	_____	_____	_____
In-house developed programs for PCs (including fourth-generation languages)	_____	_____	_____

5. The next set of questions relates to so-called micro-mainframe application systems. For the purposes of this study, we are defining this to mean the following: "Applications in which neither the mainframe host nor a microcomputer can fully carry out an activity without utilizing processing capabilities or data from the other." Do you agree with this definition?
 Yes No

If no, please tell how you would modify it: _____

6. With 1 representing agreement and 5 representing disagreement to what extent do you agree that "Within three to five years most applications that are now host-based will have a considerable amount of functionality taken over by personal computers that are linked to the host?" _____

Why? _____

- 7a. Do you believe that links between host computers and micros will be predominantly interactive, predominantly on-line batch, or about the same? (READ DEFINITION IF NEEDED)

DEFINITION: ON-LINE BATCH - where the micro performs processing on a standalone basis and, periodically, the personal computer and the host exchange data; the host may then further process the data received.

- Predominantly interactive
 Predominantly on-line batch
 About the same

Reason why: _____

- 7b. How is your firm addressing this issue?

- 7c. How does this compare to other specific products?

8a. In constructing micro-mainframe systems how common do you think each of the following approaches will be? (READ LIST BELOW) Why? (1 = very common, 5 = not common) NOTE: ALL OPTIONS MAY BE RATED "NOT COMMON" OR "VERY COMMON" - OPTIONS ARE NOT MUTUALLY EXCLUSIVE.

	<u>Rating</u>	<u>Reason Why</u>
Modification of existing software	_____	_____
Use existing data base but write new application code	_____	_____
Write entirely new applications	_____	_____

8b. How is your firm addressing this issue? _____

8c. How does this compare to other specific products? _____

9a. Generally, to what extent do you see data base linkage and synchronization as a serious problem in establishing micro-mainframe links? (1 = not a problem, 5 = a serious problem) _____

9b. How serious is this problem for systems used for analysis (e.g., spreadsheets)? _____

Why? _____

9c. How serious is this problem for production systems (e.g., order entry, payroll)? _____

Why? _____

9d. What do you see as the general solution to this problem? _____

9e. How are you addressing it? _____

10a. Do you see backup and security as significant barriers to expanded use of linked micro-mainframe applications?

Yes No If no, skip to question 13.

What are the major problems that you see? _____

10b. What do you see as the general solutions to these problems?

10c. How are you addressing it? _____

- 11a. What specific applications do you see as being the most suitable as micro-mainframe applications? (They need not be computerized applications now.) (Use workspace below.)
- 11b. Are products for these applications planned, and, if so, at what stage are you in implementing them (i.e., do not have concrete plans, are in the planning stage, applications are being developed, applications are already implemented)? (Use workspace below.)
- 11c. Do you expect users to develop these applications in-house, purchase an existing package from an outside vendor, or modify in-house an existing package? (Use workspace below.)

Application Name	Stage				Source		
	None	Plan	Dev.	Imp.	In-house	Vendor	Both
1.							
2.							
3.							
4.							
5.							

Comments:

- 1. _____
- 2. _____
- 3. _____
- 4. _____
- 5. _____

12a. In what ways do you see micro-mainframe applications increasing data communications requirements?

12b. In what ways do you see micro-mainframe applications decreasing data communications requirements?

12c. Overall, do you think the net effect will be to increase or decrease data communications requirements? By what percent?

Increase: _____% Decrease: _____% No effect: _____%

13a. With 1 representing low importance and 5 representing high importance, how important will it be for a company's micros to communicate with micros in other departments? _____

Why? _____

13b. What type of communication facility will a firm be likely to use for this type of communication? (Use workspace below.)

14a. With 1 representing low importance and 5 representing high importance, how important will it be for a company's micros to communicate with mainframes in other companies (i.e., suppliers, customer)? _____

Why? _____

14b. What types of communication facilities will a firm be likely to use for this type of communication? (Use workspace below.)

15a. With 1 representing low importance and 5 representing high importance, how important will it be for a company's micros to communicate with public data bases? _____

Why? _____

15b. What types of communication facilities will a firm be likely to use for this type of communication? (Use workspace below.)

Type of Communication Facility	Micros in Other Departments	Mainframes in Other Companies	Public Data Bases
LAN			
Existing network			
Leased lines			
WATS			
Dial up			
Public data network			
Other			

16a. Do you expect a company's micros to be linked to more than one type of mainframe (e.g., IBM and DEC)?

Yes No If no, skip to question 17.

16b. What would be the most common types of mainframe linkages?

16c. Would, typically, the same micro have to link to more than one kind of mainframe at different times?

Yes No

16d. Which of your products will facilitate this?

17a. Do you expect that a company's micros will be linked to more than one type teleprocessing environment (e.g., to both TSO and CMS, or to CICS and IMS DC)?

Yes No If yes:

17b. Which ones?

17c. Would, typically, the same micro have to link to more than one kind of software environment at different times?

Yes No

17d. Which of your products will facilitate this?

18a. Do you expect that a company's micros will be linked to more than one type of data base management system (e.g., to both IMS and IDMS)?

Yes No If yes:

18b. Which ones?

18c. Would, typically, the same micro have to link to more than one kind of DBMS at different times?

Yes No

18d. Which of your products will facilitate this?

19a. Do you expect microcomputer use in a company to accelerate the use of relational data base systems in a company?

Yes No If no, skip to question 20.

19b. Which one? _____

19c. Would this data base be located on a regular mainframe or have a special machine devoted to it? IF SPECIAL MACHINE: Which one?

19d. Which of your products will facilitate this?

20a. What other products have you introduced or planned to introduce that will address micro-mainframe issues?

20b. What functions will they perform?

20c. What hardware and software environments will they function in?

20d. When will they be available?

20e. What competitive products will they most closely compete with?
What will distinguish your product from the competition?

21. What current problems do you see micro-mainframe systems solving or alleviating?

22. What problems do you see being created or aggravated by micro-mainframe systems?

23. How do you think these new problems should be dealt with?

24. Can you provide technical descriptive material about the products discussed?

Yes No

**APPENDIX D: EXCERPTS FROM INPUT'S REPORT,
EVALUATING THE EDP LEVEL OF SERVICE**

APPENDIX D: EXCERPTS FROM INPUT'S REPORT, EVALUATING THE EDP
LEVEL OF SERVICE

A. GENERAL RECOMMENDATIONS

- Chargeback systems should be viewed as, at best, a cost-accounting tool. Periodically, such data should be used as an input to determine the cost of process or product.
- If chargeback systems are to carry out this limited function, the costing mechanisms must be greatly expanded:
 - All costs, not just hardware costs, should be tracked.
 - Software maintenance costs, especially, should be tracked by project and user. This is rarely done now.
 - Costs should be based on resources denied, not resources consumed.
- IS management should strongly distrust what it believes user satisfaction to be in the absence of objective, rigorously obtained information.
- Surveys and other attempts by IS to gain such knowledge can lead to frustration by both IS and users:

- This is true for IS, because user "satisfaction" can prove to be elusive and mercurial, seemingly reflecting last week's triumph or crisis.
- Users, on the other hand, can view such well-meaning surveys as goads that remind them of the poor service they believe they are receiving.
- Similar efforts to improve communication will often only make it easier for each side to abuse the other.
- IS should resolve these and a number of related problems, by recognizing that user expectations and IS performance should be linked. Too often the two exist, at best, in separate vacuums and, all too often, are not consciously examined.
- After examining current practice and problems, INPUT believes an initiative that would usefully serve many organizations is the "user contract," or as INPUT prefers to describe it, the "user service agreement."
- User agreements, if executed successfully, establish common standards against which performance can then be monitored.
 - This sets up the dialogue that users desire.
 - IS gets its chance to "educate" users.
 - Expectations can often be influenced and managed by IS.
 - A joint measuring process is established.
 - Regular reports and meetings provide early warning of changing needs and objectives.

- The next section is devoted to exploring the opportunities inherent in service agreements.

B. USER SERVICE AGREEMENTS

- There are four aspects to implementing user service agreements ("user contracts") in an organization:
 - Deciding whether service agreements are, in fact, suitable for a particular organization.
 - Defining the agreements' contents.
 - Establishing the initial service agreements.
 - Ensuring that IS has the resources to support the process.
- Each of these points will be discussed in this section.

I. DECIDING WHERE SERVICE AGREEMENTS ARE ADVISABLE

- Some organizations are bad bets for introducing service agreements. Examples include environments where:
 - Basic corporate policies are in a constant state of flux.
 - If the corporation cannot answer the question, "Who am I?" then users in particular areas will have similar problems consistently enunciating their needs.

- IS itself will also be buffeted in this sort of environment and will find it difficult to live up to its commitments.
- User management turnover is high and/or user management is not strong or very political. Agreements cannot be built on sand.
- The underlying business is subject to marked fluctuations that cannot be predicted or influenced by the organization. "Reaction" and "catch-up ball" are the watchwords. Agreements would not make much sense.
- This does not mean that an organization must be rigid and unchanging to benefit from service agreements. The best environment is one that is growing and dynamic.
- In addition, the corporate environment should be receptive to planning in general. The environment would be very favorable if past planning efforts resulted in bottom-line benefits that are widely perceived and accepted.

2. FACTORS DEPENDENT ON INFORMATION SYSTEMS

- Some of the critical factors for making service agreements work are dependent on the nature and capabilities within IS itself. It makes no sense to enter into agreements that IS stands little chance of fulfilling.
- For example, some "central" or "corporate" IS departments are staff, planning, or coordinative groups. They often do not have either the detailed operational knowledge or the means of allocating specific operational resources. This kind of group will find it difficult to avoid over- or under-committing resources. It will also find it difficult to make resource re-allocations.
- The capabilities of IS staff and computer resources must be candidly assessed.

- Some IS organizations may be in a rebuilding phase. Taking on voluntary commitments that would result in more failure is not the way to nurse the patient back to health.
 - On the other hand, where IS management is new and has succeeded in making internal improvements, service agreements are a way of making the new state of affairs clear to the outside world.
- Finally, there are some specific capabilities that will be required to make the process work:
 - Project- and time-estimating skills will be important for IS to carry out its contractual responsibilities. An adequate system should be in place.
 - Linked with estimating skills is the requirement to deal with performance measurement questions. As noted earlier, terminal uptime and response time are two of the most critical issues involved.
 - In many organizations, these measurements are performed incompletely or not at all.
 - It may be necessary to rely on user personnel for some measurements in these areas, in order to build trust and communication.
 - Exhibit D-1 summarizes the effects of the organizational and IS factors that affect the advisability of introducing service agreements.

3. USER-RELATED FACTORS

- Service contracts will not serve a useful purpose if relations with a particular user are getting worse or are already bad.

EXHIBIT D-1

ORGANIZATIONAL AND INFORMATION SYSTEMS FACTORS AFFECTING
ADVISABILITY OF INTRODUCING SERVICE AGREEMENTS

FACTOR	POSITIVE ELEMENT	NEUTRAL ELEMENT	NEGATIVE ELEMENT
Corporate Organization	Dynamic	Rigid	Unstable
Planning Receptivity	High		Low
Type of IS Organization	Centralized	Decentralized	Central Coordination
IS Personnel Capabilities	High		Low
IS Top Management Time in Office	Short	Medium, Long	
Hardware Capacity	Adequate		Inadequate
Telecommunications Reliability	High		Low
IS Time Estimating Track Record	Reliable		Unreliable
IS Performance Measurement Capabilities	High		Low

- There is a minimum level of trust and confidence required to make such agreements work. If this is lacking, trying to introduce a new, unfamiliar issue will, at least, further complicate matters and, at worst, make the user think IS is trying to divert attention from existing, well-known problems.
- However, where relations are improving, even if they still are not very good, a service agreement can be further evidence of IS's commitment to improvement.
- There can sometimes be a thin line between these two situations, and it can be useful to initially introduce an intermediary (from either inside or outside the firm) to assess the situation objectively.
- It is important that key users be distinguished from the average and limited users.
 - It is the key users who usually determine whether data processing will be successful in an organization and how much the use of the computer will contribute to the firm.
 - Key users are identified by a combination of:
 - The importance of the user department to the organization.
 - The proportion of IS resources (human and hardware) that the user department consumes.
 - Exhibit D-2 illustrates graphically the relationships between the three types of users--key users, average users, and limited users.
 - Generally, where a department consumes significant systems resources and/or the department is important to the company, the department will be a key user.

EXHIBIT D-2

DISTINGUISHING KEY USERS FROM OTHER USERS

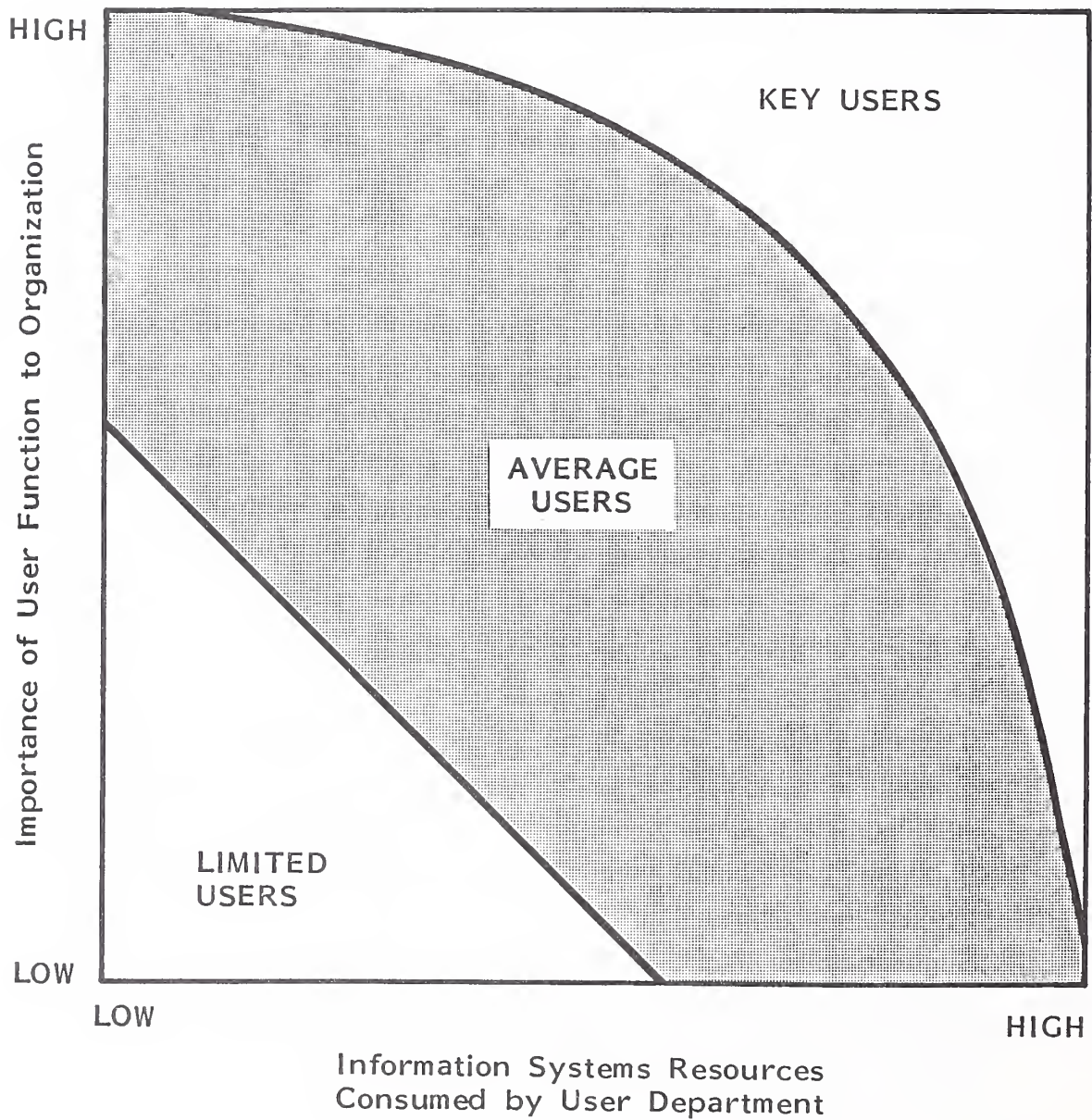

- Note, however, that where there is a pairing of extremes (high consumption—low departmental importance, or vice-versa), the department is probably not a key user.
 - Some IS organizations may find that they in fact have few key users: their biggest customers are not very important in the totality of the organization. Missionary work, which may or may not involve service agreements, would certainly be indicated.
- Knowledgeable, sophisticated users are certainly good candidates for user contracts.
 - Many of the definitional and expectation problems caused by more naive users will be absent.
 - This kind of user often is also more involved with the IS department and data processing operations.
 - Of course, they cannot be ignored so easily when things go wrong.
- Where users are increasing their use of services not supplied by IS, this can be a sign that a service agreement is needed so they receive the services they need.
 - Sometimes users go outside for services that IS cannot supply at all (e.g., certain external information data bases) or that IS cannot do feasibly (e.g., a personal computer on every analyst's desk).
 - However, sometimes users look elsewhere because they believe, rightly or wrongly, that IS cannot meet their needs. Drawing up an agreement with the user will, at the least, identify whether this is so.

- Finally, current user satisfaction as perceived by IS should not be a factor in deciding whether to establish service agreements. As shown earlier, IS is more likely to be wrong than right in this assessment.
- Exhibit D-3 summarizes the effects of these user-related factors that would affect the advisability of introducing service agreements.

4. SERVICE AGREEMENT CONTENTS

- Service agreements should focus on essentials. The following is not required:
 - Complexity.
 - Undue formality.
 - Legalisms.
 - Rigidity.
- Service agreements could become extremely large, if every element of IS-user relationships were defined. In many cases this is not necessary. Where routine operations (e.g., batch financial systems) have been operating smoothly for many years, the adage "if it ain't broke, don't fix it" should be followed.
- The areas that should be focused on are those areas that are new, critical, and/or have a significant problem potential. INPUT's research indicates that for many IS departments the critical areas will be:
 - Terminal downtime.
 - Response time.
 - Program development requests.

EXHIBIT D-3

USER-RELATED FACTORS AFFECTING
ADVISABILITY OF INTRODUCING SERVICE AGREEMENTS

FACTOR (Separate for Each User)	POSITIVE ELEMENT	NEUTRAL ELEMENT	NEGATIVE ELEMENT
Relations with User	Moderate; Bad, But Improving	Excellent	Moderate & Worsening; Bad
Amount of Outside Services Used	Increasing	Stable; Decreasing	
User Sophistication	High	Low; Medium	
Importance of EDP to User	High		Low
Proportion of IS Resources Used	High	Low; Medium	
Amount of User Involvement	High	Low; Medium	
User Satisfaction as Perceived by IS		Low, Medium, High	

- The exact issues to be dealt with will naturally vary from user to user, depending on user needs and the status of the application. However, there will be certain points that should at least be considered in every case. Exhibits D-4, D-5, and D-6 are checklists of items that should be considered for inclusion in every agreement.
- User agreements should be viewed as flexible, open-ended documents with provision for modification by either side, based on changing conditions.
 - Again, a legalistic or buyer-seller state of mind should be avoided.
 - It is important that both sides be able to give as much warning as possible to the other when adverse conditions threaten. Otherwise, the tendency will be to hope for the best and postpone bad news as long as possible.
- This raises a related question of whether chargeback rates should be included in the agreement.
- One of the main advantages to using the term "service agreement" is avoiding the word "contracts," which implies a buyer-seller relationship.
 - Most IS operations are not set up in such a way that real money (or even reliable pseudo-money) changes hands.
 - As indicated earlier, most chargeback systems are, at best, accounting conventions. Unless the chargeback system is thought through at least as well as the user agreement is, it would be a mistake to associate the two in one package.
- If charges are not included in the agreement, then what does IS get out of the agreement? Are promises being made, with nothing received in return? IS management should squarely face the fact that they are an internal service

EXHIBIT D-4

SERVICE AGREEMENT CONTENT: TERMINAL DOWNTIME CHECKLIST

- Definition, i.e., by type of malfunction
 - Local hardware
 - Communication line
 - Central hardware
 - System software
 - Applications software

- Uptime requirements by
 - Time period, e.g.,
 - Time of day
 - Day of week
 - Season
 - Location (geography, organization)
 - Equipment type

- Malfunction repair
 - Responsibility, by type of malfunction
 - Process
 - Equipment backup

- Measurement methodology, e.g.,
 - User problem logs
 - System monitors

- Measurement responsibilities
 - Reporting
 - Meetings

EXHIBIT D-5

SERVICE AGREEMENT CONTENT: RESPONSE TIME CHECKLIST

- Definition, i.e.,
 - Minimum
 - Maximum
 - Average (mean)
 - Average (median)
 - Percentile (e.g. 95th)

- Requirements by
 - Time of day
 - Time period (day of week, month, season, etc.)
 - Location (geography, organization)
 - Type of transaction

- Priorities by type of requirement
 - E.g., where contention/degradation occur

- Measurement methodology, e.g.,
 - System monitors
 - On-site stopwatch sampling

- Measurement responsibilities
 - Reporting
 - Meetings

EXHIBIT D-6

SERVICE AGREEMENT CONTENT: PROGRAM DEVELOPMENT REQUEST CHECKLIST

- Definition
 - Levels of requests

- Process
 - Forms
 - Information
 - Routing to be followed

- User responsibility
 - Screening
 - Prioritizing
 - Batching of requests
 - Benefit assessment
 - Benefit measurement

- Cost/benefit process
 - When to be applied
 - Payback criteria

- Feasibility study role
 - Content
 - Role of rapid prototyping
 - Turnaround

- Maintenance "release" cycle
 - Time period
 - Exception process

organization. All benefits are supposed to flow in one direction, hence: service agreement.

- What IS management receives is:
 - A baseline on which to be judged.
 - A measurement process agreed to by key users.
 - A standardized process for being informed of changes in user activities.

5. DEVELOPING USER SERVICE AGREEMENTS

- In most organizations there will be little initial pressure from users to establish data processing service agreements. As indicated in the study findings, there is as yet little user awareness of the concept.
- Consequently, IS can introduce user service agreements in a cautious, orderly process.
 - Exhibit D-7 shows the typical steps that should be followed in developing user service agreements.
- Most of the steps have been discussed in previous sections:
 - Make sure that top management and user managers understand the concept. It is important not to use the word "contract."
 - Be prepared to be flexible and, within reason, to modify the form of agreements to meet user demands.
 - Do not promise more than can be delivered.

EXHIBIT D-7

STEPS IN DEVELOPING USER SERVICE AGREEMENTS

1. Decide whether service agreements are advisable in the organization's environment.
2. Develop and tailor a concept for the specific organization.
3. Classify users into key, average, and limited-use categories.
4. Discuss concept with top management, key users, and selected average users.
5. Develop draft agreement guidelines.
6. Negotiate a pilot agreement with one or more average users.
7. Revise guidelines after pilot is in place.
8. Circulate revised guidelines to key users; modify as required.
9. Negotiate agreements with key users.
10. Negotiate agreements with remaining average users after arrangements with key users are working satisfactorily.
11. Negotiate agreements with limited users after all other agreements are in place.

6. INFORMATION SYSTEMS RESOURCES NEEDED

- Assuming that IS has made the correct choice in deciding to implement service agreements, the basic resources that IS needs to support the process will be in place.
- However, there will be some specialized skills and tools that will be of considerable assistance in making service agreements work. These include:
 - Cost estimating.
 - Performance measurement.
 - Decision support systems.
 - Rapid prototyping.

**APPENDIX E: EXCERPTS FROM INPUT'S REPORT,
SUPPORTING PERSONAL COMPUTER SOFTWARE**

APPENDIX E: EXCERPTS FROM INPUT'S REPORT, SUPPORTING PERSONAL COMPUTER SOFTWARE

A. ORGANIZATIONAL SIZE IS A HIDDEN FACTOR IN THE PC SOFTWARE EXPERIENCE

- The size of the organization is an often-overlooked issue in PC support. The size has an impact on:
 - The number of PCs supported.
 - The attitude toward using outside vendors and services.
- The relative strength and motivating forces of PC use vary by organization size. Users acting alone are most significant in large companies because they have the size and resources to vividly affect PC campaigns. Small companies quite often go it alone because of the absence of central IS capability. User/vendor combinations are most prevalent in small and medium-sized companies, and the similarity in size of vendor and user organizations provides an acceptable as well as a comfortable working relationship.
- Personal computing use also can be categorized by organization size. Smaller companies often look to vendors for assistance in implementing customized systems. Larger companies can mobilize resources to build, maintain, and replicate systems effective for all applicable PC users, while in medium-sized

companies there is a danger that custom software may be dependent on one person to operate and maintain it.

B. CATEGORIES OF PC SOFTWARE SUPPORT

- Adequate standard setting and enforcement provide the foundation for PC software support.
- The biggest issue for PC software selection is whether a particular application belongs on a PC. Alternatives to a PC include:
 - An information center.
 - A mainframe base.
 - A minicomputer-based turnkey.
 - A manual.
- The most important contribution to effective use of PC software is education and training. Unfortunately it is the most neglected. Good documentation is also neglected. It is difficult to convince users to document their custom programs, especially when IS systems are not necessarily good examples.
- Problem resolution is the central role of a support organization. Too often, however, PC software support is equated with problem resolution. The result is a support function relegated to "fire fighting." Problem resolution should be the backstop, not the front line, of PC support.

C. THE GREATER THE I.S. RESOURCE, THE GREATER THE POTENTIAL BENEFIT

- There are four levels of PC software support. In order of resource and expertise, they are:
 - The foundation level.
 - The commitment level.
 - The full service support level.
 - The leading-edge support level.
- It is usually advisable to implement one service level prior to the succeeding one.
- The foundation level represents the best price/performance level for most companies. This level requires a minimal amount of IS resource. Consulting services is the primary component of this level, and it establishes the framework for controlling PC software support.
- The leading edge can be the riskiest approach but can also provide the highest reward. In this support level, IS will design and implement a comprehensive set of PC applications. The main risk is that IS will not produce the right system or that users may not accept it. The reward is a comprehensive, efficient use of PCs throughout an organization.

D. DETERMINING THE LEVEL OF RESOURCE: AN ART OR A SCIENCE?

- There is no single formula for determining PC software support resource requirements. It is possible, however, to establish the order of magnitude within the problem. The major elements are related to user characteristics (i.e., the number of people who are direct hands-on PC users). More resources are required for a start-up operation as opposed to the "steady-state" of an already existing operation. Certain types of users, such as scientists, engineers, and frequent PC users, require less support.

- Other factors affecting the intensity of support demands are:
 - Ultimate recipient of output (user as president).

 - Source of data.

 - Quality of software selection process.

 - Software source.

 - Extent of multivendor sources.

 - Extent of user training.

- Taking all the above factors into account and using timesharing companies' support ratios as a guide, the ratio of PC support staff to end users will range from 1:50 to 1:300.

E. I.S. SHOULD BE THE PRIMARY SOURCE OF SUPPORT

- There are, potentially, many different sources of PC software support. A separate PC support unit in the IS department could provide support for every area. There are many other sources that also may be considered:
 - IS department in general (no specialized group).
 - Users.
 - Computer stores.
 - Hardware and software vendors.
 - PC software consultants (external consultants).
 - Training specialists (external or internal).

- It is difficult to make generalized statements since the availability and quality of stores and consultants vary, based on:
 - Geography.
 - PC hardware/software environment.
 - Application area.

- It is possible, however, to categorize these sources as being potentially primary or secondary assistance resources.

F. METHODS OF FINANCING PC SOFTWARE SUPPORT

- The key issue for providing PC software support is finding the financial resources. Too often inadequate support is spread among a wide range of functions because of improper financing. This kind of support can be worse than no support at all.
- Many IS departments assume that PC software support must be the same as a mainframe-based system; support is provided by in-house IS staff and is part of the overhead cost.
- Abdicating responsibility for support to the user will not solve the problem. The user is usually ill-equipped to support PC software. There are, however, other alternatives for financing support; these include:
 - Charging back support costs to users, either involuntarily or voluntarily.
 - "Bundled" services, where IS leases hardware, software, and support services to internal users.
 - Charging fees for individual support services.

